



paoli®



paoli®
Electric



A close-up photograph of a person wearing a blue long-sleeved shirt and green work gloves. They are using a blue and black Paoli electric tool, specifically a clutch puller, on a vehicle's axle. The tool has a long metal shaft and a blue handle with the Paoli logo. The background is dark and industrial, showing parts of a car and some cables.

GENERAL
CATALOGUE



COMPANY

L'AZIENDA

TECHNOLOGICAL INNOVATION AT YOUR FINGERTIPS

For more than 50 years DINO PAOLI SRL has been manufacturing professional impact wrenches, with the aim of supplying to every customer - from tyre changers to mechanics, from the workshop to the industry - the best available technologies.

Strong, reliable and long-lasting products are developed building on Paoli's experience.

The incessant research and the company know-how made possible the realization of impact wrenches dedicated to the industry field, infrastructures, industrial maintenance, railway, mines, oil and gas maintenance. Furthermore, every customer can benefit from a guaranteed high quality service and has the opportunity to get in touch with always evolving products.

INNOVAZIONE TECNOLOGICA A PORTATA DI MANO

DINO PAOLI SRL produce da oltre 50 anni avvitatori professionali in grado di fornire al cliente - dal gommista al meccanico, dall'officina allo stabilimento - le migliori tecnologie disponibili.

Dall'esperienza Paoli nascono prodotti che si distinguono per robustezza, affidabilità e durata.

La continua ricerca e il know-how aziendale hanno permesso inoltre di sviluppare avvitatori appositamente pensati per l'industria, le infrastrutture, la manutenzione industriale, le applicazioni ferroviarie, gli ambienti minerari e le petrolchimici.

Ogni cliente ha infine a disposizione un servizio di qualità garantita e la possibilità di confrontarsi con prodotti in continua evoluzione.

“PEOPLE, PASSION,
PROFESSIONALISM.
SINCE 1968
DINO PAOLI SRL
HAS BEEN PRODUCING
ITALIAN TECHNOLOGY.”

“PERSONE, PASSIONE,
PROFESSIONALITÀ.
DAL 1968
DINO PAOLI SRL
PRODUCE
TECNOLOGIA
ITALIANA.”



HISTORY

STORIA

Dino Paoli S.r.l. was born in 1968 and it has specialized in the production of impact wrenches used in workshops for commercial vehicles and standard road cars.

La Dino Paoli S.r.l. nasce nel 1968 e si specializza nella produzione di avvitatori utilizzati nelle officine per veicoli commerciali e automobili da strada.

1975

Dino Paoli S.r.l. starts producing impact wrenches with air exhaust trough the handle: noise and fine dusts are reduced. Paoli ecological trolleys arrive on the market.

Dino Paoli S.r.l. comincia la produzione di avvitatori con scarico nell'impugnatura: riduzione rumorosità e polveri sottili. Arrivano i carrelli ecologici Paoli.

2000

Dino Paoli S.r.l. introduces a new range of impact wrenches following the ATEX certification, dedicated to explosive environments and industrial maintenance.

Dino Paoli S.r.l. introduce una nuova gamma di avvitatori a certificazione ATEX, pensati per l'utilizzo in atmosfere esplosive e manutenzione industriale.

2018

Thanks to constant research and continuous development in the mechatronic field, Dino Paoli S.r.l. decides to renew the challenge and to double the success, to be the sole partner of the Nascar Cup Series.

Grazie alla ricerca costante e al continuo sviluppo in ambito meccatronico, Dino Paoli S.r.l. decide di rinnovare la sfida e di raddoppiare il successo, per essere per la seconda volta l'unico partner della Nascar Cup Series.

THE ORIGINS

F1 PODIUM

ECOLOGICAL PRODUCTS

HYDRAULIC RANGE

ATEX RANGE

NASCAR

MECHATRONIC DEVELOPMENT

1968

Thanks to the superior fastness and compactness of its products, Paoli becomes the official supplier for one of the most famous F1 Italian teams.

Grazie all'alta qualità della produzione e dei servizi offerti, nel 1975 Paoli diventa fornitore ufficiale di uno dei più famosi team italiani di Formula 1.

1990s

Dino Paoli S.r.l. designs and produces the new hydraulic impact wrenches, specifically created for workshops, industry and railway applications.

Dino Paoli S.r.l. progetta e realizza i nuovi avvitatori idraulici ideati per le officine, l'industria e le applicazioni ferroviarie.

2016

Thanks to the development of new mechatronic and pneumatic technologies, Dino Paoli S.r.l. becomes the official pit equipment supplier of Nascar.

Grazie allo sviluppo di nuove tecnologie meccatroniche e pneumatiche, Dino Paoli S.r.l. diventa fornitore ufficiale di avvitatori per il Campionato Nascar.

2021

LO SVILUPPO

DEVELOPMENT

PAOLI WORLDWIDE PRESENCE

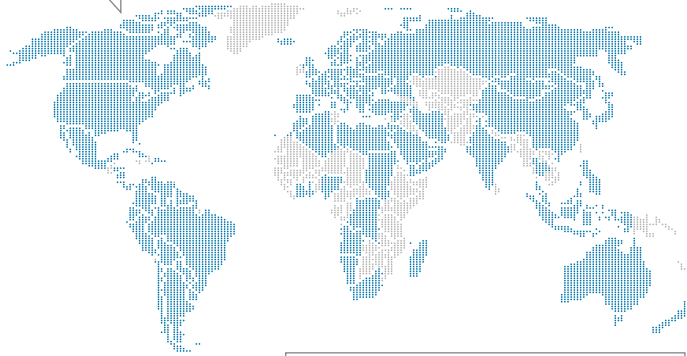

PAOLI MOTORSPORT PRESENCE

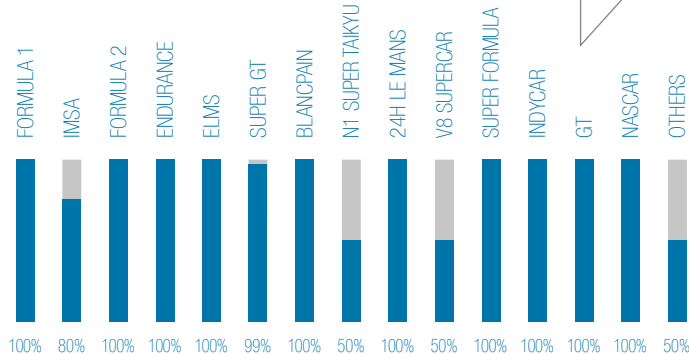

450.000
IMPACT WRENCHES



SINCE 1968

100%
F1 TEAMS



USE
PAOLI GUNS

+700
RESELLERS



IN THE WORLD

10%
TURNOVER



REINVESTED IN
R&D

40
AVERAGE AGE



OF EMPLOYEES

7000
HOURS



OF TRAINING

NATO
CERTIFICATION



NCAGE CODE:
AM610

+ 30% YOY (YEAR OVER YEAR)

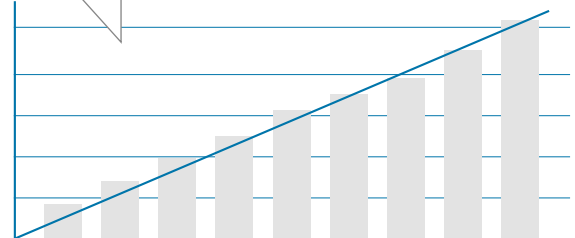

HAMMER MECHANISM TYPES

TIPOLOGIE DI MECCANISMI AD IMPULSO

3-JAW SYSTEM

SISTEMA AD ALZATA DI CAMMA A 3 GRIFFE



The 3-jaw system produces a single impact for each cycle on all 3-jaws and a high torque value. This system also gives low vibration levels. This type is suggested mainly for tightening hard joints.

- **Advantages:** power
reliability
readiness

Il sistema ad alzata di camma a 3 griffe produce un unico impatto ad ogni ciclo su tutte le 3 griffe ed un valore di coppia elevato. Si riscontrano altresì bassi livelli di vibrazione.

Il suo impiego è suggerito principalmente per avvitamenti rigidi.

- **Vantaggi:** potenza
affidabilità
spunto

PRODUCTS - PRODOTTI

DP 176 - DP 196 - DP 217 - DP 236 - DP 251 - DP 256 BG - DP 320 - DP 321
DP 362 BG - DP 382 - DP 635 - DPH 340 - DPH 341 - DPH 351 - DPH 362
DPH 381 - DPH 340 M - DPH 341 M - DPH 351 M

PIN-CLUTCH SYSTEM IN OIL BATH

SISTEMA PIN-CLUTCH A BAGNO D'OLIO



The pin-clutch system produces a single impact for each cycle. The strokes are made by two pins which are pitched directly on the shaft. This creates a balanced impulse and a lower vibration level compared to the other systems.

- **Advantages:** low vibrations
low noisiness
thanks to the oil bath: less maintenance
improved durability of the impact mechanism
improved precision of the strokes

Il sistema pin-clutch produce un singolo impatto ad ogni ciclo. La battuta è generata da due spine che si innestano direttamente sull'albero. Si ottiene un impulso bilanciato e con un livello di vibrazioni di gran lunga inferiori agli altri meccanismi ad impulsi.

- **Vantaggi:** basse vibrazioni
bassa rumorosità
grazie al bagno d'olio: minore manutenzione
maggiore durabilità della massa battente
maggior precisione di battuta

PRODUCTS - PRODOTTI

DP 247

TIPOLOGIE DI MECCANISMI AD IMPULSO

HAMMER MECHANISM TYPES

TWIN-HAMMER SYSTEM SISTEMA A DOPPIO MARTELLO



The twin-hammer system produces a double impact for each cycle on both sides of the shaft. The use of 2 opposite hammers allows to obtain a balanced impact. It is mainly used for 1/2 inch impact wrenches.

- **Advantages:** cost effective
durability due to lower effort

Il sistema a doppio martello produce un impatto doppio ad ogni ciclo su entrambi i lati dell'albero. L'utilizzo di 2 innesti (martelli) opposti permette di ottenere un impulso bilanciato. Utilizzato tipicamente negli avvitatori da 1/2 pollice.

- **Vantaggi:** più economico
durabilità dovuta al minor sforzo

PRODUCTS - PRODOTTI

DP 36 - DP 1800 - DP 1800 PLUS - RED
DEVIL 2.0 - DP 3450 - DP 3400 DP 1000 -
DP 3500 - DP 3700 - DP3800

JUMBO SYSTEM SISTEMA JUMBO



The jumbo system produces a single impact for each cycle. This system is mainly used for 1/2 inch small impact wrenches. This hammer mechanism is extremely strong and performing.

- **Advantages:** speediness
performances

Il sistema jumbo produce un singolo impatto ad ogni ciclo. Questo sistema è prevalentemente utilizzato per avvitatori da 1/2 pollice di ridotte dimensioni. È un tipo di massa battente estremamente robusto e performante.

- **Vantaggi:** velocità
prestazioni

PRODUCTS - PRODOTTI

DP 1050 - DP 1040

2-JAW SYSTEM SISTEMA AD ALZATA DI CAMMA A 2 GRIFFE



The 2-jaw system produces a single impact for each cycle on both jaws and a high torque value.

This system also gives low vibration levels. It is present on small tools and its use is suggested mainly for tightening hard joints.

Il sistema ad alzata di camma a 2 griffe produce un unico impatto ad ogni ciclo su entrambe le griffe ed un valore di coppia elevato.

Si riscontrano altresì bassi livelli di vibrazione. È presente su avvitatori di piccole dimensioni ed il suo impiego è suggerito principalmente per avvitiamenti rigidi.

PRODUCTS - PRODOTTI

DP 92 XC - DP 92 - DP 93

NEW PRODUCTS HIGHLIGHTS

NUOVI PRODOTTI IN EVIDENZA

I

IMPACT WRENCHES

AVVITATORI

51 DP 251 RHM

M

ELECTRO-HYDRAULIC RANGE WITH MECHANICAL LEVER

GAMMA ELETTO-IDRAULICA CON LEVA MECCANICA

164 DYNO-M Gasoline

C

ELECTRIC RANGE T9 BATTERIES

GAMMA ELETTRICA CON BATTERIE T9

96 T9 Battery

88 Tornado

90 Typhon Brushless 1/2"

91 Typhon Brushless 3/4"

93 Typhoon Brushless RHM 3/4"

92 Typhoon Brushless RHM 1"

D

DP LIFT JACKS

SOLLEVATORI DP LIFT

179 DPLIFT 442 P

181 DPLIFT 430 L

181 DPLIFT 442 N

182 DPLIFT 444 N

190 DPLIFT 150/72

191 DPLIFT 200/65

189 DPLIFT 200/90

INDICE

I	IMPACT WRENCHES AVVITATORI	10	M	ELECTRO-HYDRAULIC RANGE WITH MECHANICAL LEVER GAMMA ELETTRO-IDRAULICA CON LEVA MECCANICA	150
T	AIRTOOLS UTENSILI PNEUMATICI	68	D	DPLIFT JACKS SOLLEVATORI DPLIFT	168
C	CORDLESS AVVITATORI A BATTERIA	74	S	AIR SUPPLY SYSTEMS ALIMENTAZIONE ARIA COMPRESSA	200
N	TORQUE CONTROL RANGE GAMMA A COPPIA CONTROLLATA	98	A	ACCESSORIES ACCESSORI	220
X	ATEX IMPACT WRENCHES AVVITATORI ATEX	110	P	PRODUCT CARE ASSISTENZA TECNICA	250
E	MOBILE WORKING STATIONS POSTAZIONI DI LAVORO MOBILE	126	F	FAQ DOMANDE FREQUENTI	256
H	ELECTRO-HYDRAULIC RANGE GAMMA ELETTRO-IDRAULICA	144			

IMPACT WRENCHES

Dino Paoli impact wrenches are iconic.

The Motorsport experience gives birth to models always able to provide the users with the best available technology.

Dino Paoli, from its Italian headquarters, designs and sells daily and heavy duty impact wrenches: a complete range conceived to meet the needs of professionals working in tyre and mechanical workshops, as well as in the industrial sectors.

Paoli impact wrenches are widely used for the following applications:

- Automotive field:
 - cars
 - commercial and light industrial vehicles
 - trucks, buses and other heavy vehicles
- Industrial field:
 - infrastructures
 - construction site and shipyard
 - Industrial assembly
 - Railway applications
 - Mines, oil and gas
 - and many more

AVVITATORI

Gli avvitatori Dino Paoli sono una icona.

L'esperienza Motorsport dà vita a modelli sempre in grado di fornire agli utenti la migliore tecnologia disponibile.

Dino Paoli, dalla sede italiana, progetta e vende avvitatori per applicazioni standard e pesanti: una gamma completa concepita per soddisfare le esigenze dei professionisti che operano presso officine meccaniche e gommisti, oltre che nei settori industriali.

Gli avvitatori Paoli trovano largo impiego nelle seguenti applicazioni:

- *Ambito automotive:*
 - *automobili*
 - *veicoli commerciali*
 - *camion, autobus e altri mezzi pesanti*
- *Settore industriale:*
 - *infrastrutture*
 - *cantieri e costruzioni navali*
 - *montaggi industriali*
 - *applicazioni ferroviarie*
 - *ambienti minerari e petrolchimici*
 - *e molto altro*











IMPACT WRENCHES AVVITATORI

PAOLI IMPACT WRENCHES APPLICATIONS

APPLICAZIONI DEGLI AVVITATORI PAOLI









BEST FOR APPLICAZIONI

	3/8"		1/2"							3/4"					
	BUTTERFLY	DP 92	DP 93	DP 1040	DP 1050	DP 36	DP 1800	DP 1800 PLUS	RED DEVIL 2.0	DP 1800	DP 3450	DP 176	DP 196	DP 3400	DP 217
 Mechanical workshops <i>Officine meccaniche</i>	■	■	■	■	■	■	■	■		■	■	■	■		■
 Cars, van, suv tyreshops <i>Gommisti vetture, van, suv</i>						■	■	■	■	■					
 Commercial vehicles tyreshops <i>Gommisti veicoli commerciali</i>											■	■	■	■	■
 Heavy vehicles tyreshops <i>Gommisti mezzi pesanti</i>															
 Industrial assembly <i>Montaggi industriali</i>	■	■	■	■	■	■	■	■		■	■	■	■	■	■
 Usable with Paoli Mobile Working Station <i>Utilizzabile con Postazione di Lavoro Mobile Paoli</i>		■	■			■						■	■		■
 Infrastructures <i>Infrastrutture</i>															■
 Construction site and shipyard <i>Cantieri e costruzioni navali</i>															■
 Railways applications <i>Applicazioni ferroviarie</i>						■									■

APPLICAZIONI DEGLI AVVITATORI PAOLI

PAOLI IMPACT WRENCHES APPLICATIONS

BEST FOR APPLICAZIONI

	1"										1" 1/2			2"	2" 1/2
	DP 1000	DP 3500	DP 236	DP 247	DP 251	DP 3700	DP 3800	DP 256 BG	DP 320	DP 362 BG	DP 321	DP 362 BG	DP 382	DP 635	DP 635
 Mechanical workshops <i>Officine meccaniche</i>			■	■		■			■						
 Cars, van, suv tyreshops <i>Gommisti vetture, van, suv</i>															
 Commercial vehicles <i>Gommisti veicoli commerciali</i>	■		■												
 Heavy vehicles <i>Gommisti mezzi pesanti</i>		■		■		■	■	■	■						
 Industrial assembly <i>Montaggi industriali</i>	■	■	■	■	■				■	■		■	■	■	■
 Usable with Paoli Mobile Working Stations <i>Utilizzabile con Postazione di Lavoro Mobile Paoli</i>		■	■	■			■	■	■						
 Infrastructures <i>Infrastrutture</i>			■		■	■	■	■	■	■	■	■	■	■	■
 Construction site and shipyard <i>Cantieri e costruzioni navali</i>					■		■	■	■	■	■	■	■	■	■
 Railways applications <i>Applicazioni ferroviarie</i>					■			■		■	■	■	■	■	■

BUTTERFLY

PROFESSIONAL RANGE

3/8"



Product code	<i>Codice prodotto</i>	BUTTERFLY.001
Square drive	<i>Attacco quadro</i>	3/8"
Bolt range	<i>Capacità bullone</i>	M5-M10
Max torque	<i>Coppia massima</i>	110 Nm (80 ft-lb)
Working torque	<i>Coppia raccomandata</i>	10-100 Nm - 10-75 ft-lb
Weight	<i>Peso</i>	0,53 kg - 1.17 lbs
Free speed	<i>Velocità libera</i>	12000 rpm
Impacts number	<i>Numero impatti</i>	1000/min
Working pressure	<i>Pressione di utilizzo</i>	6,3 bar - 91 psi
Air inlet	<i>Ingresso aria</i>	1/4" NPT
Inner hose diameter	<i>Diametro interno tubo</i>	9,5 mm - 0.374 in
Length	<i>Lunghezza</i>	139.8 mm - 5.5 in
Side to center	<i>Ingombro centro lato</i>	20 mm - 0.79 in
Vibration level - triaxial	<i>Livello vibrazioni - triassiale</i>	4,0 m/s ²
Sound pressure level	<i>Pressione sonora</i>	92 dB(A)



INCLUDED IN THE BOX INCLUSI NELLA SCATOLA



The package contains: grease for hammer mechanism, oil for impact wrench motors, operating and maintenance manual, after-sales suggestions.

La confezione contiene: grasso per masse battenti, olio per i motori degli avvitatori, manuale d'uso e manutenzione, indicazioni post-vendita.

MAIN FEATURES CARATTERISTICHE PRINCIPALI

HAMMER MECHANISM TIPO MASSE BATTENTI



Two hammers (rocking dog clutch)
Two hammers (rocking dog clutch)

ANVIL TYPE TIPO ALBERO



With ring, without hole
Con anello, senza foro

AIR EXHAUST DIRECTION DIREZIONE SCARICO ARIA



Through the handle
Impugnatura

HAMMER MECHANISM LUBRICATION LUBRIFICAZIONE MASSE BATTENTI



Grease
Grasso

BEST FOR APPLICAZIONI



Industrial assembly
Montaggi industriali



Mechanical workshops
Officine meccaniche



AVAILABLE DISPONIBILE

BUTTERFLY XC - BUTTERFLY.002
with screwdriver connection
con attacco cacciavite

SQUARE DRIVE ATTACCO QUADRO	1/4" FEM. HEX.
LENGHT LUNGHEZZA	146,3 mm 5.75 in

DP 92

HEAVY DUTY RANGE

3/8"



Product code	<i>Codice prodotto</i>	000092.00001
Square drive	<i>Attacco quadro</i>	3/8"
Bolt range	<i>Capacità bullone</i>	M5-M10
Max torque	<i>Coppia massima</i>	120 Nm - 90 ft-lb
Working torque	<i>Coppia raccomandata</i>	30-70 Nm - 20-50 ft-lb
Weight	<i>Peso</i>	1,4 kg - 3.0 lbs
Free speed	<i>Velocità libera</i>	7200 rpm
Impacts number	<i>Numero impatti</i>	1200/min
Working pressure	<i>Pressione di utilizzo</i>	6,3 bar - 91 psi
Air inlet	<i>Ingresso aria</i>	1/4" BSP
Inner hose diameter	<i>Diametro interno tubo</i>	8 mm - 0.315 in
Length	<i>Lunghezza</i>	146 mm - 5.75 in
Side to center	<i>Ingombro centro lato</i>	25 mm - 0.98 in
Vibration level - triaxial	<i>Livello vibrazioni - triassiale</i>	2,5 m/s ²
Sound pressure level	<i>Pressione sonora</i>	82 dB(A)



INCLUDED IN THE BOX INCLUSI NELLA SCATOLA



The package contains: hanger, grease for hammer mechanism, oil for impact wrench motors, 4 socket head cap screws, 4 lock washers, 2 front gaskets (0,1 mm - 0,2 mm), operating and maintenance manual, after-sales suggestions.

La confezione contiene: gancio di sostegno, grasso per masse battenti, olio per i motori degli avvitatori, 4 viti a testa cilindrica, 4 rondelle di sicurezza, 2 guarnizioni anteriori (0,1 mm - 0,2 mm), manuale d'uso e manutenzione, indicazioni post-vendita.

MAIN FEATURES CARATTERISTICHE PRINCIPALI

HAMMER MECHANISM TIPO MASSE BATTENTI



2-jaw
2 griffe

ANVIL TYPE TIPO ALBERO



With ring, with hole
Con anello, con foro

AIR EXHAUST DIRECTION DIREZIONE SCARICO ARIA



Through the handle
Impugnatura

HAMMER MECHANISM LUBRICATION LUBRIFICAZIONE MASSE BATTENTI



Grease
Grasso

BEST FOR APPLICAZIONI



Industrial assembly
Montaggi industriali



Mechanical workshops
Officine meccaniche



Very compact and light
Molto compatto e leggero

Intensive use
Uso intensivo

Possibility of silenced and
ecological air exhaust
*Possibilità di scarico
silenziato ed ecologico*

Air exhaust through the handle
• less noise
• no harmful dust

*Scarico dell'aria esausta
nell'impugnatura*
• minore rumorosità
• assenza di polveri nocive

AVAILABLE DISPONIBILE

DP 92 XC - 0092XC.00001
with screwdriver connection
con attacco cacciavite

**SQUARE DRIVE
ATTACCO QUADRO** 1/4" FEM. HEX.

**LENGHT
LUNGHEZZA** 156 mm
6.14 in

Ergonomic aluminium handle
Impugnatura ergonomica in alluminio

Available with power register on demand
*Disponibile con registro di potenza su
richiesta*

DP 93

HEAVY DUTY RANGE

1/2"



Product code	<i>Codice prodotto</i>	000093.00001
Square drive	<i>Attacco quadro</i>	1/2"
Bolt range	<i>Capacità bullone</i>	M5-M10
Max torque	<i>Coppia massima</i>	140 Nm - 100 ft-lb
Working torque	<i>Coppia raccomandata</i>	30-70 Nm - 20-50 ft-lb
Weight	<i>Peso</i>	1,45 kg - 3.2 lbs
Free speed	<i>Velocità libera</i>	7200 rpm
Impacts number	<i>Numero impatti</i>	1200/min
Working pressure	<i>Pressione di utilizzo</i>	6,3 bar - 91 psi
Air inlet	<i>Ingresso aria</i>	1/4" BSP
Inner hose diameter	<i>Diametro interno tubo</i>	8 mm - 0.315 in
Length	<i>Lunghezza</i>	146 mm - 5.75 in
Side to center	<i>Ingombro centro lato</i>	25 mm - 0.98 in
Vibration level - triaxial	<i>Livello vibrazioni - triassiale</i>	2,5 m/s ²
Sound pressure level	<i>Pressione sonora</i>	88 dB(A)



INCLUDED IN THE BOX INCLUSI NELLA SCATOLA



The package contains: hanger, grease for hammer mechanism, oil for impact wrench motors, 4 socket head cap screws, 4 lock washers, 2 front gaskets (0,1 mm - 0,2 mm), operating and maintenance manual, after-sales suggestions.

La confezione contiene: gancio di sostegno, grasso per masse battenti, olio per i motori degli avvitatori, 4 viti a testa cilindrica, 4 rondelle di sicurezza, 2 guarnizioni anteriori (0,1 mm - 0,2 mm), manuale d'uso e manutenzione, indicazioni post-vendita.

MAIN FEATURES CARATTERISTICHE PRINCIPALI

HAMMER MECHANISM TIPO MASSE BATTENTI



2-jaw
2 griffe

ANVIL TYPE TIPO ALBERO



With ring, with hole
Con anello, con foro

AIR EXHAUST DIRECTION DIREZIONE SCARICO ARIA



Through the handle
Impugnatura

HAMMER MECHANISM LUBRICATION LUBRIFICAZIONE MASSE BATTENTI



Grease
Grasso

BEST FOR APPLICAZIONI



Industrial assembly
Montaggi industriali



Mechanical workshops
Officine meccaniche



DP 1040

PROFESSIONAL RANGE

1/2"



Product code	<i>Codice prodotto</i>	001040.00001
Square drive	<i>Attacco quadro</i>	1/2"
Bolt range	<i>Capacità bullone</i>	M10-M16
Max torque	<i>Coppia massima</i>	650 Nm - 479 ft-lb
Working torque	<i>Coppia raccomandata</i>	100-500 Nm - 80-370 ft-lb
Weight	<i>Peso</i>	1,30 kg - 2.86 lbs
Free speed	<i>Velocità libera</i>	9500 rpm
Impacts number	<i>Numero impatti</i>	1600/min
Working pressure	<i>Pressione di utilizzo</i>	6,3 bar - 90 psi
Air inlet	<i>Ingresso aria</i>	1/4" NPT
Inner hose diameter	<i>Diametro interno tubo</i>	8 mm - 0.315 in
Length	<i>Lunghezza</i>	96 mm - 3.86 in
Side to center	<i>Ingombro centro lato</i>	31 mm
Vibration level - triaxial	<i>Livello vibrazioni - triassiale</i>	12,4 m/s ²
Sound pressure level	<i>Pressione sonora</i>	95 dB(A)



INCLUDED IN THE BOX INCLUSI NELLA SCATOLA



The package contains: grease for hammer mechanism, oil for impact wrench motors, operating and maintenance manual, after-sales suggestions.

La confezione contiene: grasso per masse battenti, olio per i motori degli avvitatori, manuale d'uso e manutenzione, indicazioni post-vendita.

MAIN FEATURES CARATTERISTICHE PRINCIPALI

HAMMER MECHANISM TIPO MASSE BATTENTI



Jumbo
Jumbo

ANVIL TYPE TIPO ALBERO



With ring, without hole
Con anello, senza foro

AIR EXHAUST DIRECTION DIREZIONE SCARICO ARIA



Through the handle
Impugnatura

HAMMER MECHANISM LUBRICATION LUBRIFICAZIONE MASSE BATTENTI



Grease
Grasso

BEST FOR APPLICAZIONI



Industrial assembly
Montaggi industriali



Mechanical workshops
Officine meccaniche

THE MOST COMPACT 1/2" MODEL! IL MODELLO DA 1/2" PIU' COMPATTO!

Energy efficient motor: maximum performance and long life
Motore ad alta efficienza energetica: prestazioni massime e lunga durata

New Jumbo hammer type
Nuova massa battente Jumbo



Aluminium body
Corpo in alluminio

Built in air power regulator
Registro di potenza incorporato

F/R Switch
Comando per cambio direzione

Rubber coated handle
Impugnatura rivestita in gomma

DP 1050

PROFESSIONAL RANGE

1/2"



Product code	<i>Codice prodotto</i>	001050.00001
Square drive	<i>Attacco quadro</i>	1/2"
Bolt range	<i>Capacità bullone</i>	M10-M16
Max torque	<i>Coppia massima</i>	700 Nm - 520 ft-lb
Working torque	<i>Coppia raccomandata</i>	100-600 Nm - 80-450 ft-lb
Weight	<i>Peso</i>	1,3 kg - 2.8 lbs
Free speed	<i>Velocità libera</i>	9000 rpm
Impacts number	<i>Numero impatti</i>	1150/min
Working pressure	<i>Pressione di utilizzo</i>	6,3 bar - 91 psi
Air inlet	<i>Ingresso aria</i>	1/4" NPT
Inner hose diameter	<i>Diametro interno tubo</i>	8 mm - 0.315 in
Length	<i>Lunghezza</i>	110 mm - 4.33 in
Side to center	<i>Ingombro centro lato</i>	28.5 mm - 1.12 in
Vibration level - triaxial	<i>Livello vibrazioni - triassiale</i>	12,1 m/s ²
Sound pressure level	<i>Pressione sonora</i>	95 dB(A)



INCLUDED IN THE BOX INCLUSI NELLA SCATOLA



The package contains: grease for hammer mechanism, oil for impact wrench motors, hanger, operating and maintenance manual, after-sales suggestions.

La confezione contiene: grasso per masse battenti, olio per i motori degli avvitatori, gancio di sospensione, manuale d'uso e manutenzione, indicazioni post-vendita.

MAIN FEATURES CARATTERISTICHE PRINCIPALI

HAMMER MECHANISM TIPO MASSE BATTENTI



Jumbo
Jumbo

ANVIL TYPE TIPO ALBERO



With ring, without hole
Con anello, senza foro

AIR EXHAUST DIRECTION DIREZIONE SCARICO ARIA



Through the handle
Impugnatura

HAMMER MECHANISM LUBRICATION LUBRIFICAZIONE MASSE BATTENTI



Grease
Grasso

BEST FOR APPLICAZIONI



Industrial assembly
Montaggi industriali



Mechanical workshops
Officine meccaniche

Light and ergonomic
Leggero ed ergonomico



Aluminium body
Corpo in alluminio

F/R Switch
Comando per cambio direzione

Rubber coated handle
Impugnatura rivestita in gomma

Device for left handed operators
Supporto per operatori mancini

Built in air power regulator
Registro di potenza incorporato

 paoli

DP 36

HEAVY DUTY RANGE

1/2"



Product code	<i>Codice prodotto</i>	000036.00003
Square drive	<i>Attacco quadro</i>	1/2"
Bolt range	<i>Capacità bullone</i>	M10-M16
Max torque	<i>Coppia massima</i>	650 Nm - 480 ft-lb
Working torque	<i>Coppia raccomandata</i>	108-350 Nm - 80-260 ft-lb
Weight	<i>Peso</i>	2,3 kg - 5.07 lbs
Free speed	<i>Velocità libera</i>	5600 rpm
Impacts number	<i>Numero impatti</i>	2200/min
Working pressure	<i>Pressione di utilizzo</i>	6,3 bar - 91 psi
Air inlet	<i>Ingresso aria</i>	1/4" Gas
Inner hose diameter	<i>Diametro interno tubo</i>	8 mm - 0.315 in
Length	<i>Lunghezza</i>	176 mm - 6.93 in
Side to center	<i>Ingombro centro lato</i>	31 mm - 1.2 in
Vibration level - triaxial	<i>Livello vibrazioni - triassiale</i>	5,028 m/s ²
Sound pressure level	<i>Pressione sonora</i>	96,9 dB(A)



INCLUDED IN THE BOX INCLUSI NELLA SCATOLA



The package contains: hanger, grease for hammer mechanism, oil for impact wrench motors, 4 socket head cap screws, 4 lock washers, 2 front gaskets (0,1 mm - 0,2 mm), operating and maintenance manual, after-sales suggestions.

La confezione contiene: gancio di sostegno, grasso per masse batteriti, olio per i motori degli avvitatori, 4 viti a testa cilindrica, 4 rondelle di sicurezza, 2 guarnizioni anteriori (0,1 mm - 0,2 mm), manuale d'uso e manutenzione, indicazioni post-vendita.

MAIN FEATURES CARATTERISTICHE PRINCIPALI

HAMMER MECHANISM TIPO MASSE BATTENTI



Twin hammer
Doppio martello

ANVIL TYPE TIPO ALBERO



With ring, without hole
Con anello, senza foro

AIR EXHAUST DIRECTION DIREZIONE SCARICO ARIA



Through the handle
Impugnatura

HAMMER MECHANISM LUBRICATION LUBRIFICAZIONE MASSE BATTENTI



Grease
Grasso

BEST FOR APPLICAZIONI



Industrial assembly
Montaggi industriali



Cars, van, SUV tyreshops
Gommisti vetture, van, SUV



Mechanical workshops
Officine meccaniche

THE MOST DURABLE 1/2" MODEL! IL MODELLO DA 1/2" PIÙ DUREVOLE!



AVAILABLE DISPONIBILE

DP 36 AL - 000036.00005

ANVIL LENGTH LUNGHEZZA ALBERO	72 mm 2.84 in
----------------------------------	------------------

WEIGHT PESO	2,45 kg 5,4 lbs
----------------	--------------------

DP 36 - 000036.00001



With ring, with hole
Con anello, con foro

BEST PRACTICE MIGLIORE APPLICAZIONE

INDUSTRIAL ASSEMBLY
ASSEMBLAGGIO INDUSTRIALE
GUARD RAIL MAINTENANCE
MANUTENZIONE GUARD RAIL

DP 1800

PROFESSIONAL RANGE

1/2"-3/4"



Product code	<i>Codice prodotto</i>	001800.00001
Square drive	<i>Attacco quadro</i>	1/2"
Bolt range	<i>Capacità bullone</i>	M10-M16
Max torque	<i>Coppia massima</i>	1100 Nm - 800 ft-lb
Working torque	<i>Coppia raccomandata</i>	100-950 Nm - 80-700 ft-lb
Weight	<i>Peso</i>	2,1 kg - 4.6 lbs
Free speed	<i>Velocità libera</i>	8500 rpm
Impacts number	<i>Numero impatti</i>	1050/min
Working pressure	<i>Pressione di utilizzo</i>	6,3 bar - 91 psi
Air inlet	<i>Ingresso aria</i>	1/4" NPT
Inner hose diameter	<i>Diametro interno tubo</i>	8 mm - 0.315 in
Length (with short anvil)	<i>Lunghezza (con albero corto)</i>	194,5 mm - 7.66 in
Side to center	<i>Ingombro centro lato</i>	34.8 mm - 1.37 in
Vibration level - triaxial	<i>Livello vibrazioni - triassiale</i>	6,5 m/s ²
Sound pressure level	<i>Pressione sonora</i>	96 dB(A)



INCLUDED IN THE BOX INCLUSI NELLA SCATOLA



The package contains: grease for hammer mechanism, oil for impact wrench motors, operating and maintenance manual, after-sales suggestions.

La confezione contiene: grasso per masse battenti, olio per i motori degli avvitatori, manuale d'uso e manutenzione, indicazioni post-vendita.

MAIN FEATURES CARATTERISTICHE PRINCIPALI

HAMMER MECHANISM TIPO MASSE BATTENTI



Twin hammer
Doppio martello

ANVIL TYPE TIPO ALBERO



With ring, without hole
Con anello, senza foro

AIR EXHAUST DIRECTION DIREZIONE SCARICO ARIA



Through the handle
Impugnatura

HAMMER MECHANISM LUBRICATION LUBRIFICAZIONE MASSE BATTENTI



Grease
Grasso

BEST FOR APPLICAZIONI



Light industrial assembly
Montaggi industriali leggeri



Cars, van, SUV tyreshops
Gommisti vetture, van, SUV



Mechanical workshops
Officine meccaniche

PROFESSIONAL RANGE BEST SELLER



AVAILABLE DISPONIBILE

DP 1800 AL - 001800.00002

ANVIL LENGTH LUNGHEZZA ALBERO	51,4 mm 2.02 in
WEIGHT PESO	2,29 kg 5.05 lbs

AVAILABLE: 3/4" VERSION DISPONIBILE: VERSIONE DA 3/4"

DP 1800 3/4" - 001800.00019

BOLT RANGE CAPACITÀ BULLONE	M16-M24
MAX TORQUE COPPIA MASSIMA	1265 Nm 933 ft-lb
WORKING TORQUE COPPIA RACCOMANDATA	115-1092 Nm 84.8-805 ft-lb
LENGTH LUNGHEZZA	200 mm 7.87 in
WEIGHT PESO	2,3 kg 5.0 lbs



DP 1800 PLUS

PROFESSIONAL RANGE

1/2"



Product code	<i>Codice prodotto</i>	1800PL.00001
Square drive	<i>Attacco quadro</i>	1/2"
Bolt range	<i>Capacità bullone</i>	M12-M24
Max torque	<i>Coppia massima</i>	1650 Nm - 1200 ft-lb
Working torque	<i>Coppia raccomandata</i>	150-900 Nm - 110-670 ft-lb
Weight	<i>Peso</i>	1,65 kg - 14.33 lbs
Free speed	<i>Velocità libera</i>	9000 rpm
Impacts number	<i>Numero impatti</i>	1850/min
Working pressure	<i>Pressione di utilizzo</i>	6,3 bar - 91 psi
Air inlet	<i>Ingresso aria</i>	1/4" NPT
Inner hose diameter	<i>Diametro interno tubo</i>	8 mm - 0.315 in
Length (with short anvil)	<i>Lunghezza (con albero corto)</i>	182 mm - 7.16 in
Side to center	<i>Ingombro centro lato</i>	35 mm - 1.38 in
Vibration level - triaxial	<i>Livello vibrazioni - triassiale</i>	4,7 m/s ²
Sound pressure level	<i>Pressione sonora</i>	88 dB(A)



INCLUDED IN THE BOX INCLUSI NELLA SCATOLA



The package contains: grease for hammer mechanism, oil for impact wrench motors, operating and maintenance manual, after-sales suggestions.

La confezione contiene: grasso per masse battenti, olio per i motori degli avvitatori, manuale d'uso e manutenzione, indicazioni post-vendita.

MAIN FEATURES CARATTERISTICHE PRINCIPALI

HAMMER MECHANISM TIPO MASSE BATTENTI



Twin hammer
Doppio martello

ANVIL TYPE TIPO ALBERO



With ring, without hole
Con anello, senza foro

AIR EXHAUST DIRECTION DIREZIONE SCARICO ARIA



Through the handle
Impugnatura

HAMMER MECHANISM LUBRICATION LUBRIFICAZIONE MASSE BATTENTI



Grease
Grasso

BEST FOR APPLICAZIONI



Light industrial assembly
Montaggi industriali leggeri



Cars, van, SUV tyre shops
Gommisti vetture, van, SUV



Mechanical workshops
Officine meccaniche

Optimized weight/maximum
loosening power ratio
Rapporto ottimizzato peso/potenza
massima di svitamento

Magnesium alloy front and back covers
Cover frontale e posteriore in lega di magnesio

D.01.28.0015

Hanger (optional)
Gancio di sospensione
(opzionale)

Built-in air power regulator
Registro di potenza incorporato

Ergonomic handle
Impugnatura ergonomica

Lighter than
the DP 1800 model
Più leggero del
modello DP 1800



AVAILABLE DISPONIBILE

DP 1800 PLUS AL - 1800PL.00002

ANVIL LENGTH LUNGHEZZA ALBERO	48 mm 1.9 in
WEIGHT PESO	1,8 kg 4 lbs



RED DEVIL 2.0

STREET LEGAL



HEAVY DUTY RANGE

1/2"

Product code	<i>Codice prodotto</i>	RDEVSL.00003
Square drive	<i>Attacco quadro</i>	1/2"
Bolt range	<i>Capacità bullone</i>	M10-M16
Max torque	<i>Coppia massima</i>	1000 Nm - 740 ft-lb
Working torque	<i>Coppia raccomandata</i>	80-800 Nm - 60-590 ft-lb
Weight	<i>Peso</i>	2,4 kg - 5.3 lbs
Free speed	<i>Velocità libera</i>	12000 rpm
Impacts number	<i>Numero impatti</i>	1600/min
Working pressure	<i>Pressione di utilizzo</i>	7 bar - 101 psi
Air inlet	<i>Ingresso aria</i>	1/4" NPT
Inner hose diameter	<i>Diametro interno tubo</i>	13 mm - 0.512 in
Length	<i>Lunghezza</i>	192,6 mm - 7.58 in
Side to center	<i>Ingombro centro lato</i>	40 mm - 1.57 in
Vibration level - triaxial	<i>Livello vibrazioni - triassiale</i>	9,1 m/s ²
Sound pressure level	<i>Pressione sonora</i>	97 dB(A)



INCLUDED IN THE BOX INCLUSI NELLA SCATOLA



The package contains: grease for hammer mechanism, oil for impact wrench motors, 4 socket head cap screws, 4 lock washers, operating and maintenance manual, after-sales suggestions.

La confezione contiene: grasso per masse battenti, olio per i motori degli avvitatori, 4 viti a testa cilindrica, 4 rondelle di sicurezza, manuale d'uso e manutenzione, indicazioni post-vendita.

MAIN FEATURES CARATTERISTICHE PRINCIPALI

HAMMER MECHANISM TIPO MASSE BATTENTI



Twin hammer
Doppio martello

ANVIL TYPE TIPO ALBERO



With ring, without hole
Con anello, senza foro

AIR EXHAUST DIRECTION DIREZIONE SCARICO ARIA



Sides exhaust
Bilaterale

HAMMER MECHANISM LUBRICATION LUBRIFICAZIONE MASSE BATTENTI



Grease
Grasso

BEST FOR APPLICAZIONI



Cars, van, suv tyreshops
Gommisti vetture, van, suv

7075 aluminium (ergal) front cover
Cover anteriore in alluminio 7075 (ergal)

Increasing performance at increasing pressure
(max pressure 14 bar)
*Prestazioni in aumento con l'aumento di pressione
(pressione massima 14 bar)*

Ergonomic PVC cover
Cover ergonomica in PVC

Side inverter
Invertitore laterale

Very fast!
Molto veloce!

Side air exhaust,
motorsport-racing effect!
*Scarico aria laterale,
effetto gara motorsport!*

FROM MOTORSPORT TO AUTOMOTIVE
DAL MOTORSPORT ALL'AUTOMOTIVE

 paoli

 REDDEVIL™
WHEEL GUNS

DP 3450

PROFESSIONAL RANGE

3/4"



Product code	<i>Codice prodotto</i>	003450.00001
Square drive	<i>Attacco quadro</i>	3/4"
Bolt range	<i>Capacità bullone</i>	M14-M24
Max torque	<i>Coppia massima</i>	1500 Nm - 1100 ft-lb
Working torque	<i>Coppia raccomandata</i>	200-1300 Nm - 150-960 ft-lb
Weight	<i>Peso</i>	3,7 kg - 8.3 lbs
Free speed	<i>Velocità libera</i>	6000 rpm
Impacts number	<i>Numero impatti</i>	1100/min
Working pressure	<i>Pressione di utilizzo</i>	6,3 bar - 91 psi
Air inlet	<i>Ingresso aria</i>	3/8" NPT
Inner hose diameter	<i>Diametro interno tubo</i>	13 mm - 0.512 in
Length	<i>Lunghezza</i>	221 mm - 8.7 in
Side to center	<i>Ingombro centro lato</i>	43 mm - 1.7 in
Vibration level - triaxial	<i>Livello vibrazioni - triassiale</i>	6,7 m/s ²
Sound pressure level	<i>Pressione sonora</i>	89,8 dB(A)



INCLUDED IN THE BOX INCLUSI NELLA SCATOLA



The package contains: grease for hammer mechanism, oil for impact wrench motors, operating and maintenance manual, after-sales suggestions.

La confezione contiene: grasso per masse battenti, olio per i motori degli avvitatori, manuale d'uso e manutenzione, indicazioni post-vendita.

MAIN FEATURES CARATTERISTICHE PRINCIPALI

HAMMER MECHANISM TIPO MASSE BATTENTI



Twin hammer
Doppio martello

ANVIL TYPE TIPO ALBERO



With ring, with hole
Con anello, con foro

AIR EXHAUST DIRECTION DIREZIONE SCARICO ARIA



Through the handle
Impugnatura

HAMMER MECHANISM LUBRICATION LUBRIFICAZIONE MASSE BATTENTI



Grease
Grasso

BEST FOR APPLICAZIONI



Industrial assembly
Montaggi industriali



Commercial vehicles - mechanics
Veicoli commerciali - meccanica



Mechanical workshops
Officine meccaniche



Light 3/4" model
Modello da 3/4" leggero

3-Positions power regulator
Registro di potenza a 3 posizioni

Composite body
Corpo in materiale composito

Ergonomic handle
Impugnatura ergonomica

DP 176

HEAVY DUTY RANGE

3/4"



Product code	<i>Codice prodotto</i>	000176.00001
Square drive	<i>Attacco quadro</i>	3/4"
Bolt range	<i>Capacità bullone</i>	M12-M24
Max torque	<i>Coppia massima</i>	1000 Nm - 740 ft-lb
Working torque	<i>Coppia raccomandata</i>	210-780 Nm - 160-580 ft-lb
Weight	<i>Peso</i>	4,2 kg - 9.2 lbs
Free speed	<i>Velocità libera</i>	5600 rpm
Impacts number	<i>Numero impatti</i>	900/min
Working pressure	<i>Pressione di utilizzo</i>	6,3 bar - 91 psi
Air inlet	<i>Ingresso aria</i>	3/8" BSP
Inner hose diameter	<i>Diametro interno tubo</i>	13 mm - 0.512 in
Length (with short anvil)	<i>Lunghezza (con albero corto)</i>	191 mm - 7.5 in
Side to center	<i>Ingombro centro lato</i>	43 mm - 1.7 in
Vibration level - triaxial	<i>Livello vibrazioni - triassiale</i>	6,4 m/s ²
Sound pressure level	<i>Pressione sonora</i>	89 dB(A)



INCLUDED IN THE BOX INCLUSI NELLA SCATOLA



The package contains: hanger, handle kit (in compliance with the CE UNI EN ISO 11148-6 norm), grease for hammer mechanism, oil for impact wrench motors, 4 socket head cap screws, 4 lock washers, 2 front gaskets (0,1 mm - 0,2 mm), operating and maintenance manual, after-sales suggestions.

La confezione contiene: gancio di sostegno, kit maniglia (in conformità con la normativa CE UNI EN ISO 11148-6), grasso per masse battenti, olio per i motori degli avvitatori, 4 viti a testa cilindrica, 4 rondelle di sicurezza, 2 guarnizioni anteriori (0,1 mm - 0,2 mm), manuale d'uso e manutenzione, indicazioni post-vendita.

MAIN FEATURES CARATTERISTICHE PRINCIPALI

HAMMER MECHANISM TIPO MASSE BATTENTI



3-jaw
3 griffe

ANVIL TYPE TIPO ALBERO



With ring, with hole
Con anello, con foro

AIR EXHAUST DIRECTION DIREZIONE SCARICO ARIA



Through the handle
Impugnatura

HAMMER MECHANISM LUBRICATION LUBRIFICAZIONE MASSE BATTENTI



Grease
Grasso

BEST FOR APPLICAZIONI



Usable with Paoli Mobile Working Stations
Utilizzabile con Postazione di Lavoro Mobile Paoli



Industrial assembly
Montaggi industriali



Commercial vehicles - mechanics
Veicoli commerciali - meccanica



Mechanical workshops
Officine meccaniche

Combined bearing. It avoids fast drying!
Cuscinetto combinato. Evita l'asciugamento rapido!

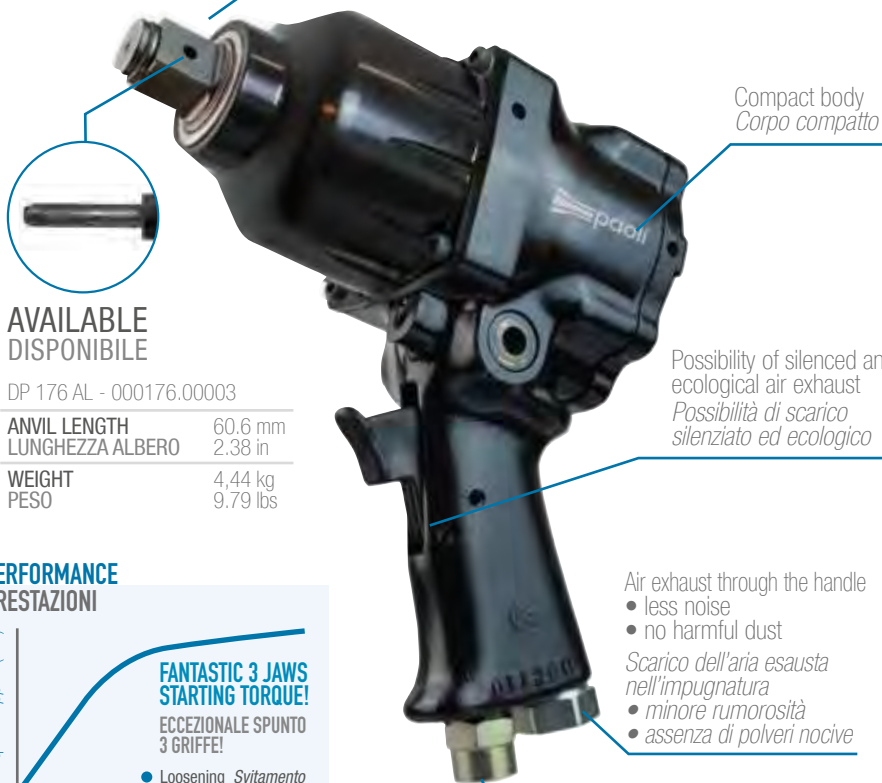

AVAILABLE DISPONIBILE

DP 176 AL - 000176.00003

ANVIL LENGTH LUNGHEZZA ALBERO	60.6 mm 2.38 in
----------------------------------	--------------------

WEIGHT PESO	4,44 kg 9.79 lbs
----------------	---------------------

PERFORMANCE PRESTAZIONI



Sensible torque increase over 5"
Aumento di coppia sensibile oltre i 5"

Resistance over 7 bar
Resistenza oltre i 7 bar

Air exhaust through the handle

- less noise
- no harmful dust

Scarico dell'aria esausta
nell'impugnatura

- minore rumorosità
- assenza di polveri nocive

Available with power register on demand
Disponibile con registro di potenza su
richiesta

DP 196

HEAVY DUTY RANGE

3/4"



Product code	<i>Codice prodotto</i>	000196.00004
Square drive	<i>Attacco quadro</i>	3/4"
Bolt range	<i>Capacità bullone</i>	M12-M24
Max torque	<i>Coppia massima</i>	1300 Nm - 960 ft-lb
Working torque	<i>Coppia raccomandata</i>	300-1000 Nm - 210-730 ft-lb
Weight	<i>Peso</i>	4,9 kg - 10.8 lbs
Free speed	<i>Velocità libera</i>	4800 rpm
Impacts number	<i>Numero impatti</i>	900/min
Working pressure	<i>Pressione di utilizzo</i>	6,3 bar - 91 psi
Air inlet	<i>Ingresso aria</i>	3/8" BSP
Inner hose diameter	<i>Diametro interno tubo</i>	13 mm - 0.512 in
Length (with short anvil)	<i>Lunghezza (con albero corto)</i>	218,2 mm - 8.6 in
Side to center	<i>Ingombro centro lato</i>	43 mm - 1.7 in
Vibration level - triaxial	<i>Livello vibrazioni - triassiale</i>	7,4 m/s ²
Sound pressure level	<i>Pressione sonora</i>	92 dB(A)



INCLUDED IN THE BOX INCLUSI NELLA SCATOLA



The package contains: handle kit (in compliance with the CE UNI EN ISO 11148-6 norm), grease for hammer mechanism, oil for impact wrench motors, 4 socket head cap screws, 4 lock washers, 2 front gaskets (0,1 mm - 0,2 mm), operating and maintenance manual, after-sales suggestions.

La confezione contiene: kit maniglia (in conformità con la normativa CE UNI EN ISO 11148-6), grasso per masse battenti, olio per i motori degli avvitatori, 4 viti a testa cilindrica, 4 rondelle di sicurezza, 2 guarnizioni anteriori (0,1 mm - 0,2 mm), manuale d'uso e manutenzione, indicazioni post-vendita.

MAIN FEATURES CARATTERISTICHE PRINCIPALI

HAMMER MECHANISM TIPO MASSE BATTENTI



3-jaw
3 griffe

ANVIL TYPE TIPO ALBERO



With ring, without hole
Con anello, senza foro

AIR EXHAUST DIRECTION DIREZIONE SCARICO ARIA



Through the handle
Impugnatura

HAMMER MECHANISM LUBRICATION LUBRIFICAZIONE MASSE BATTENTI



Grease
Grasso

BEST FOR APPLICAZIONI



Usable with Paoli Mobile Working Stations
Utilizzabile con Postazione di Lavoro Mobile Paoli



Industrial assembly
Montaggi industriali



Commercial vehicles - tyres
Veicoli commerciali - gomme



Commercial vehicles - mechanics
Veicoli commerciali - meccanica



Particularly performing
in vertical screwing
*Particolarmente performante
in avvvitamenti verticali*

Side inverter
Invertitore laterale

Compact body
Corpo compatto

Air exhaust through the handle
• less noise
• no harmful dust

*Scarico dell'aria esausta
nell'impugnatura*
• minore rumorosità
• assenza di polveri nocive

Available with power register on demand
*Disponibile con registro di potenza su
richiesta*

AVAILABLE DISPONIBILE

DP 196 AL - 000196.00010

ANVIL LENGTH LUNGHEZZA ALBERO	61 mm 2.4 in
WEIGHT PESO	5,23 kg 11.53 lbs

PERFORMANCE PRESTAZIONI



Sensible torque increase over 5"
Aumento di coppia sensibile oltre i 5"

Resistance over 7 bar
Resistenza oltre i 7 bar

DP 3400

PROFESSIONAL RANGE

3/4"



Product code	<i>Codice prodotto</i>	003400.00001
Square drive	<i>Attacco quadro</i>	3/4"
Bolt range	<i>Capacità bullone</i>	M14-M24
Max torque	<i>Coppia massima</i>	1700 Nm - 1250 ft-lb
Working torque	<i>Coppia raccomandata</i>	200-1350 Nm - 150-1000 ft-lb
Weight	<i>Peso</i>	5,2 kg - 11.4 lbs
Free speed	<i>Velocità libera</i>	5500 rpm
Impacts number	<i>Numero impatti</i>	1100/min
Working pressure	<i>Pressione di utilizzo</i>	6,3 bar - 91 psi
Air inlet	<i>Ingresso aria</i>	3/8" NPT
Inner hose diameter	<i>Diametro interno tubo</i>	13 mm - 0.512 in
Length (with short anvil)	<i>Lunghezza (con albero corto)</i>	226 mm - 8.9 in
Side to center	<i>Ingombro centro lato</i>	48,5 mm - 1.9 in
Vibration level - triaxial	<i>Livello vibrazioni - triassiale</i>	13,1 m/s ²
Sound pressure level	<i>Pressione sonora</i>	92 dB(A)



INCLUDED IN THE BOX INCLUSI NELLA SCATOLA



The package contains: grease for hammer mechanism, oil for impact wrench motors, handle kit (in compliance with the CE UNI EN ISO 11148-6 norm), operating and maintenance manual, after-sales suggestions.

La confezione contiene: grasso per masse battenti, olio per i motori degli avitatori, kit maniglia (in conformità con la normativa CE UNI EN ISO 11148-6), manuale d'uso e manutenzione, indicazioni post-vendita.

MAIN FEATURES CARATTERISTICHE PRINCIPALI

HAMMER MECHANISM TIPO MASSE BATTENTI



Twin hammer
Doppio martello

ANVIL TYPE TIPO ALBERO



With ring, without hole
Con anello, senza foro

AIR EXHAUST DIRECTION DIREZIONE SCARICO ARIA



Through the handle
Impugnatura

HAMMER MECHANISM LUBRICATION LUBRIFICAZIONE MASSE BATTENTI



Grease
Grasso

BEST FOR APPLICAZIONI



Industrial assembly
Montaggi industriali



Commercial vehicles - tyres
Veicoli commerciali - gomme



Commercial vehicles - mechanics
Veicoli commerciali - meccanica

Optimized power/weight ratio
Rapporto potenza/peso ottimizzato

Improved motor to avoid seizing
Motore migliorato per evitare il grippaggio



AVAILABLE DISPONIBILE

DP 3400 AL - 003400.00002

ANVIL LENGTH LUNGHEZZA ALBERO	156,5 mm 6.16 in
----------------------------------	---------------------

WEIGHT PESO	6,55 kg 14.44 lbs
----------------	----------------------

3-Positions
power regulator
Registro di potenza
a 3 posizioni

Aluminium body
Corpo in alluminio

Ergonomic trigger
Leva di avviamento ergonomica

DP 217

HEAVY DUTY RANGE

3/4"



Product code	<i>Codice prodotto</i>	000217.00001
Square drive	<i>Attacco quadro</i>	3/4"
Bolt range	<i>Capacità bullone</i>	M14-M24
Max torque	<i>Coppia massima</i>	1700 Nm - 1260 ft-lb
Working torque	<i>Coppia raccomandata</i>	350-1100 Nm - 240-820 ft-lb
Weight	<i>Peso</i>	5,9 kg - 13.1 lbs
Free speed	<i>Velocità libera</i>	5400 rpm
Impacts number	<i>Numero impatti</i>	1000/min
Working pressure	<i>Pressione di utilizzo</i>	6,3 bar - 91 psi
Air inlet	<i>Ingresso aria</i>	1/2" BSP
Inner hose diameter	<i>Diametro interno tubo</i>	13 mm - 0.512 in
Length (with short anvil)	<i>Lunghezza (con albero corto)</i>	221 mm - 8.7 in
Side to center	<i>Ingombro centro lato</i>	48 mm - 1.9 in
Vibration level - triaxial	<i>Livello vibrazioni - triassiale</i>	9,4 m/s ²
Sound pressure level	<i>Pressione sonora</i>	102 dB(A)



INCLUDED IN THE BOX INCLUSI NELLA SCATOLA



The package contains: lifting eye bolt, handle kit (in compliance with the CE UNI EN ISO 11148-6 norm), grease for hammer mechanism, oil for impact wrench motors, 4 socket head cap screws, 4 lock washers, 2 front gaskets (0,1 mm - 0,2 mm), operating and maintenance manual, after-sales suggestions.

La confezione contiene: golfare, kit maniglia (in conformità con la normativa CE UNI EN ISO 11148-6), grasso per masse battenti, olio per i motori degli avvitatori, 4 viti a testa cilindrica, 4 rondelle di sicurezza, 2 guarnizioni anteriori (0,1 mm - 0,2 mm), manuale d'uso e manutenzione, indicazioni post-vendita.

MAIN FEATURES CARATTERISTICHE PRINCIPALI

HAMMER MECHANISM TIPO MASSE BATTENTI



3-jaw
3 griffe

ANVIL TYPE TIPO ALBERO



With ring, without hole
Con anello, senza foro

AIR EXHAUST DIRECTION DIREZIONE SCARICO ARIA



Through the handle
Impugnatura

HAMMER MECHANISM LUBRICATION LUBRIFICAZIONE MASSE BATTENTI



Grease
Grasso

BEST FOR APPLICAZIONI



Mechanical workshops
Officine meccaniche



Infrastructures
Infrastrutture



Industrial assembly
Montaggi industriali



Railways applications
Applicazioni ferroviarie



Commercial vehicles - tyres
Veicoli commerciali - gomme



Construction site and shipyard
Cantieri e costruzioni navali



Usable with Paoli Mobile Working Stations
Utilizzabile con Postazione di Lavoro Mobile Paoli

AVAILABLE DISPONIBILE

DP 217 AL - 000217.00002

ANVIL LENGTH
LUNGHEZZA ALBERO 118,9 mm
4,68 in

WEIGHT
PESO 6,6 kg
14.7 lbs

BEST SELLER PRODUCT PRODOTTO BEST SELLER

SAFETY SHIELD
Available (page 232)



Ergal Cover
• lighter
• shock-resistant

Cuffia in Ergal
• più leggera
• resistente agli urti e agli sforzi

Air exhaust through the handle
• less noise
• no harmful dust

Scarico dell'aria esausta nell'impugnatura
• minore rumorosità
• assenza di polveri nocive

PERFORMANCE PRESTAZIONI



Sensible torque increase over 5"
Aumento di coppia sensibile oltre i 5"

Resistance over 7 bar
Resistenza oltre i 7 bar

Available with power register on demand
Disponibile con registro di potenza su richiesta

paoli

DP 1000

PROFESSIONAL RANGE

1"



Product code	<i>Codice prodotto</i>	001000.00001
Square drive	<i>Attacco quadro</i>	1"
Bolt range	<i>Capacità bullone</i>	M16-M30
Max torque	<i>Coppia massima</i>	1550 Nm - 1150 ft-lb
Working torque	<i>Coppia raccomandata</i>	200-1300 Nm - 150-960 ft-lb
Weight	<i>Peso</i>	3,7 kg - 8.3 lbs
Free speed	<i>Velocità libera</i>	6000 rpm
Impacts number	<i>Numero impatti</i>	1100/min
Working pressure	<i>Pressione di utilizzo</i>	6,3 bar - 91 psi
Air inlet	<i>Ingresso aria</i>	3/8" NPT
Inner hose diameter	<i>Diametro interno tubo</i>	13 mm - 0.512 in
Length	<i>Lunghezza</i>	228,5 mm - 9 in
Side to center	<i>Ingombro centro lato</i>	43 mm - 1.7 in
Vibration level - triaxial	<i>Livello vibrazioni - triassiale</i>	6,7 m/s ²
Sound pressure level	<i>Pressione sonora</i>	89,8 dB(A)



INCLUDED IN THE BOX INCLUSI NELLA SCATOLA



The package contains: grease for hammer mechanism, oil for impact wrench motors, operating and maintenance manual, after-sales suggestions.

La confezione contiene: grasso per masse battenti, olio per i motori degli avvitatori, manuale d'uso e manutenzione, indicazioni post-vendita.

MAIN FEATURES CARATTERISTICHE PRINCIPALI

HAMMER MECHANISM TIPO MASSE BATTENTI



Twin hammer
Doppio martello

ANVIL TYPE TIPO ALBERO



With ring, with hole
Con anello, con foro

AIR EXHAUST DIRECTION DIREZIONE SCARICO ARIA



Through the handle
Impugnatura

HAMMER MECHANISM LUBRICATION LUBRIFICAZIONE MASSE BATTENTI



Grease
Grasso

BEST FOR APPLICAZIONI



Industrial assembly
Montaggi industriali



Commercial vehicles
Veicoli commerciali



Lightweight Screwing
Avvitamenti leggeri



Approaching Bolts
Avvicinamento bulloni

The 1" square drive impact wrench for light uses
L'avvitatore con attacco quadro da 1" per utilizzi leggeri



AVAILABLE DISPONIBILE

DP 1000 AL - 001000.00002

ANVIL LENGTH
LUNGHEZZA ALBERO 152,5 mm
6 in

WEIGHT
PESO 4,66 kg
10.3 lbs

DP 3500

PROFESSIONAL RANGE

1"



Product code	<i>Codice prodotto</i>	003500.00001
Square drive	<i>Attacco quadro</i>	1"
Bolt range	<i>Capacità bullone</i>	M18-M39
Max torque	<i>Coppia massima</i>	2950 Nm - 2180 ft-lb
Working torque	<i>Coppia raccomandata</i>	500-2200 Nm - 350-1600 ft-lb
Weight	<i>Peso</i>	5,7 kg - 12.5 lbs
Free speed	<i>Velocità libera</i>	4500 rpm
Impacts number	<i>Numero impatti</i>	950/min
Working pressure	<i>Pressione di utilizzo</i>	6.3 bar - 91 psi
Air inlet	<i>Ingresso aria</i>	1/2" NPT
Inner hose diameter	<i>Diametro interno tubo</i>	13 mm - 0.512 in
Length (with short anvil)	<i>Lunghezza (con albero corto)</i>	255,6 mm - 10,06 in
Side to center	<i>Ingombro centro lato</i>	55,5 mm - 2.18 in
Vibration level - triaxial	<i>Livello vibrazioni - triassiale</i>	6,1 m/s ²
Sound pressure level	<i>Pressione sonora</i>	92 dB(A)



INCLUDED IN THE BOX INCLUSI NELLA SCATOLA



The package contains: grease for hammer mechanism, oil for impact wrench motors, operating and maintenance manual, after-sales suggestions.

La confezione contiene: grasso per masse battenti, olio per i motori degli avvitatori, manuale d'uso e manutenzione, indicazioni post-vendita.

MAIN FEATURES CARATTERISTICHE PRINCIPALI

HAMMER MECHANISM TIPO MASSE BATTENTI



Twin hammer
Doppio martello

ANVIL TYPE TIPO ALBERO



With ring, with hole
Con anello, con foro

AIR EXHAUST DIRECTION DIREZIONE SCARICO ARIA



Through the handle
Impugnatura

HAMMER MECHANISM LUBRICATION LUBRIFICAZIONE MASSE BATTENTI



Grease
Grasso

BEST FOR APPLICAZIONI



Industrial assembly
Montaggi industriali



Heavy vehicles
Mezzi pesanti



B.34.0192

AVAILABLE DISPONIBILE

Threaded exhaust adapter for Paoli Trolley to direct the outgoing air
Adattatore per carrelli Paoli per scarico filettato per canalizzare l'aria in uscita



AVAILABLE DISPONIBILE

DP 3500 AL - 003500.00002

ANVIL LENGTH 161,4 mm
LUNGHEZZA ALBERO 6.35 in

WEIGHT 6,7 kg
PESO 14.8 lbs

Optimized power/weight ratio
Rapporto potenza/peso ottimizzato

3-Positions
power regulator
Registro di potenza
a 3 posizioni



Ergonomic handle
Maniglia ergonomica



DP 236

HEAVY DUTY RANGE

1"



Product code	<i>Codice prodotto</i>	000236.00030
Square drive	<i>Attacco quadro</i>	1"
Bolt range	<i>Capacità bullone</i>	M18-M33
Max torque	<i>Coppia massima</i>	2500 Nm - 1850 ft-lb
Working torque	<i>Coppia raccomandata</i>	500-1700 Nm - 370-1240 ft-lb
Weight	<i>Peso</i>	7,2 kg - 16.0 lbs
Free speed	<i>Velocità libera</i>	4300 rpm
Impacts number	<i>Numero impatti</i>	780/min
Working pressure	<i>Pressione di utilizzo</i>	6,3 bar - 91 psi
Air inlet	<i>Ingresso aria</i>	1/2" BSP
Inner hose diameter	<i>Diametro interno tubo</i>	13 mm - 0.512 in
Length (with short anvil)	<i>Lunghezza (con albero corto)</i>	235,3 mm - 9.26 in
Side to center	<i>Ingombro centro lato</i>	50 mm - 1.97 in
Vibration level - triaxial	<i>Livello vibrazioni - triassiale</i>	7,3 m/s ²
Sound pressure level	<i>Pressione sonora</i>	94 dB(A)



INCLUDED IN THE BOX INCLUSI NELLA SCATOLA



The package contains: handle (in compliance with the CE UNI EN ISO 11148-6 norm), grease for hammer mechanism, oil for impact wrench motors, 4 socket head cap screws, 4 lock washers, 2 front gaskets (0,1 mm - 0,2 mm), operating and maintenance manual, after-sales suggestions.

La confezione contiene: maniglia (in conformità con la normativa CE UNI EN ISO 11148-6), grasso per masse battenti, olio per i motori degli avvitatori, 4 viti a testa cilindrica, 4 rondelle di sicurezza, 2 guarnizioni anteriori (0,1 mm - 0,2 mm), manuale d'uso e manutenzione, indicazioni post-vendita.

MAIN FEATURES CARATTERISTICHE PRINCIPALI

HAMMER MECHANISM TIPO MASSE BATTENTI



3-jaw
3 griffe

ANVIL TYPE TIPO ALBERO



With ring, with hole
Con anello, con foro

AIR EXHAUST DIRECTION DIREZIONE SCARICO ARIA



Through the handle
Impugnatura

HAMMER MECHANISM LUBRICATION LUBRIFICAZIONE MASSE BATTENTI



Grease
Grasso

BEST FOR APPLICAZIONI



Mechanical workshops
Officine meccaniche



Industrial assembly
Montaggi industriali



Infrastructures
Infrastrutture

Recommended for industrial use
Consigliato per uso industriale



AVAILABLE DISPONIBILE

DP 236 AL - 000236.00031

ANVIL LENGTH LUNGHEZZA ALBERO	145 mm 5.7 in
WEIGHT PESO	8,3 kg 18.3 lbs

PERFORMANCE PRESTAZIONI



Sensible torque increase over 5"
Aumento di coppia sensibile oltre i 5"

Resistance over 7 bar
Resistenza oltre i 7 bar

Powerful and light
Potente e leggero



Air exhaust through the handle

- less noise
- no harmful dust

*Scarico dell'aria esausta
nell'impugnatura*

- minore rumorosità
- assenza di polveri nocive

Available with power register on demand
Disponibile con registro di potenza su richiesta



DP 247

HEAVY DUTY RANGE

1"



Product code	<i>Codice prodotto</i>	000247.00001
Square drive	<i>Attacco quadro</i>	1"
Bolt range	<i>Capacità bullone</i>	M18-M39
Max torque	<i>Coppia massima</i>	3000 Nm - 2210 ft-lb
Working torque	<i>Coppia raccomandata</i>	600-1900 Nm - 440-1400 ft-lb
Weight	<i>Peso</i>	8,3 kg - 18.3 lbs
Free speed	<i>Velocità libera</i>	4200 rpm
Impacts number	<i>Numero impatti</i>	750/min
Working pressure	<i>Pressione di utilizzo</i>	6,3 bar - 91 psi
Air inlet	<i>Ingresso aria</i>	1/2" BSP
Inner hose diameter	<i>Diametro interno tubo</i>	13 mm - 0.512 in
Length (with short anvil)	<i>Lunghezza (con albero corto)</i>	282 mm - 11.1 in
Side to center	<i>Ingombro centro lato</i>	50 mm - 1.97 in
Vibration level - triaxial	<i>Livello vibrazioni - triassiale</i>	4,1 m/s ²
Sound pressure level	<i>Pressione sonora</i>	94 dB(A)



INCLUDED IN THE BOX INCLUSI NELLA SCATOLA



The package contains: handle kit (in compliance with the CE UNI EN ISO 11148-6 norm), oil for pneumatic motors, operating and maintenance manual, after-sales suggestions.

La confezione contiene: kit maniglia (in conformità con la normativa CE UNI EN ISO 11148-6), olio per motori pneumatici, manuale d'uso e manutenzione, indicazioni post-vendita.

MAIN FEATURES CARATTERISTICHE PRINCIPALI

HAMMER MECHANISM TIPO MASSE BATTENTI



Pin-clutch
Pin-clutch

ANVIL TYPE TIPO ALBERO



With ring, with hole
Con anello, con foro

AIR EXHAUST DIRECTION DIREZIONE SCARICO ARIA



Through the handle
Impugnatura

HAMMER MECHANISM LUBRICATION LUBRIFICAZIONE MASSE BATTENTI



Oil
Olio

BEST FOR APPLICAZIONI



Mechanical workshops
Officine meccaniche



Industrial assembly
Montaggi industriali



Heavy vehicles
Mezzi pesanti

REINFORCED HAMMER MECHANISM. STRENGTH AND DURABILITY MASSA BATTENTE RINFORZATA. ROBUSTEZZA E DURABILITÀ

TRUCKS BEST SELLER BEST SELLER PER CAMION



Pin-Clutch hammer mechanism with oil bath lubrication system
Long-lasting hammer mechanism life
*Massa battente pin-clutch a bagno d'olio
Lunga vita alla massa battente*

Ergal cover
• lighter
• shock resistant
*Cuffia in ergal
• più leggera
• resistente agli urti e agli sforzi*

Ergonomic inverter.
Motorsport shape
*Invertitore ergonomico.
Forma in stile motorsport*

Air exhaust through the handle
• less noise
• no harmful dust
*Scarico dell'aria esausta nell'impugnatura
• minore rumorosità
• assenza di polveri nocive*

AVAILABLE DISPONIBILI

DP 247 AL - 000247.00003

ANVIL LENGTH LUNGHEZZA ALBERO	132 mm 5.2 in
----------------------------------	------------------

WEIGHT PESO	9,2 kg 20.3 lbs
----------------	--------------------

DP 247 AM - 000247.00002

ANVIL LENGTH LUNGHEZZA ALBERO	62 mm 2.44 in
----------------------------------	------------------

WEIGHT PESO	8,77 kg 19.2 lbs
----------------	---------------------

Available with power register on demand
Disponibile con registro di potenza su richiesta



DP 251

HEAVY DUTY RANGE

1"



Product code	<i>Codice prodotto</i>	000251.00017
Square drive	<i>Attacco quadro</i>	1"
Bolt range	<i>Capacità bullone</i>	M18-M39
Max torque	<i>Coppia massima</i>	3100 Nm - 2290 ft-lb
Working torque	<i>Coppia raccomandata</i>	700-2180 Nm - 550-1610 ft-lb
Weight	<i>Peso</i>	9 kg - 20 lbs
Free speed	<i>Velocità libera</i>	3100 rpm
Impacts number	<i>Numero impatti</i>	780/min
Working pressure	<i>Pressione di utilizzo</i>	6,3 bar - 91 psi
Air inlet	<i>Ingresso aria</i>	1/2" BSP
Inner hose diameter	<i>Diametro interno tubo</i>	16 mm - 0.630 in
Length (with short anvil)	<i>Lunghezza (con albero corto)</i>	271 mm - 10.67 in
Side to center	<i>Ingombro centro lato</i>	57.5 mm - 2.26 in
Vibration level - triaxial	<i>Livello vibrazioni - triassiale</i>	4,8 m/s ²
Sound pressure level	<i>Pressione sonora</i>	101 dB(A)



INCLUDED IN THE BOX INCLUSI NELLA SCATOLA



The package contains: lifting eye bolt, handle kit (in compliance with the CE UNI EN ISO 11148-6 norm), grease for hammer mechanism, oil for impact wrench motors, 4 socket head cap screws, 4 lock washers, 2 front gaskets (0,1 mm - 0,2 mm), operating and maintenance manual, after-sales suggestions.

La confezione contiene: golfare, kit maniglia (in conformità con la normativa CE UNI EN ISO 11148-6), grasso per masse battenti, olio per i motori degli avvitatori, 4 viti a testa cilindrica, 4 rondelle di sicurezza, 2 guarnizioni anteriori (0,1 mm - 0,2 mm), manuale d'uso e manutenzione, indicazioni post-vendita.

MAIN FEATURES CARATTERISTICHE PRINCIPALI

HAMMER MECHANISM TIPO MASSE BATTENTI



3-jaw
3 griffe

ANVIL TYPE TIPO ALBERO



With ring, with hole
Con anello, con foro

AIR EXHAUST DIRECTION DIREZIONE SCARICO ARIA



Through the handle
Impugnatura

HAMMER MECHANISM LUBRICATION LUBRIFICAZIONE MASSE BATTENTI



Grease
Grasso

BEST FOR APPLICAZIONI



Industrial assembly
Montaggi industriali



Infrastructures
Infrastrutture



Railways applications
Applicazioni ferroviarie



Construction site and shipyard
Cantieri e costruzioni navali



Usable with Paoli Mobile Working Stations
Utilizzabile con Postazione di Lavoro Mobile Paoli

HEAVY DUTY IMPACT WRENCH FOR INDUSTRIAL APPLICATION AVVITATORE HEAVY DUTY PER APPLICAZIONI INDUSTRIALI

Increased weight/power ratio
Rapporto peso/potenza aumentato

RADIAL HAMMER MECHANISM

RHM Radial Hammer Mechanism for intensive industrial use
Massa Battente RHM Radial Hammer Mechanism per uso intensivo Industriale



NEW OPTIONAL!
NUOVO OPTIONAL!

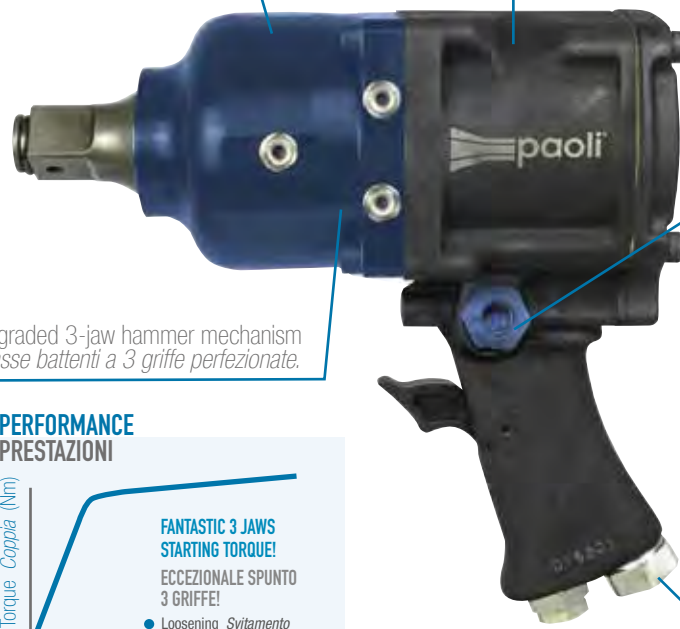

Upgraded 3-jaw hammer mechanism
Masse battenti a 3 griffe perfezionate.

PERFORMANCE PRESTAZIONI



Sensible torque increase over 5"
Aumento di coppia sensibile oltre i 5"

Resistance over 7 bar
Resistenza oltre i 7 bar

AVAILABLE DISPONIBILI

DP 251 RHM - 251RHM.00001

DP 251 RHM AL - 251RHM.00002

SAFETY SHIELD
Available (page 232)



3-Positions power regulator
Registro di potenza a 3 posizioni

Air exhaust through the handle

- less noise
- no harmful dust

Scarico dell'aria esausta nell'impugnatura

- minore rumorosità
- assenza di polveri nocive

Available with power register on demand
Disponibile con registro di potenza su richiesta



DP 3700

PROFESSIONAL RANGE

1"



Product code	<i>Codice prodotto</i>	003700.00001
Square drive	<i>Attacco quadro</i>	1"
Bolt range	<i>Capacità bullone</i>	M18-M39
Max torque	<i>Coppia massima</i>	3200 Nm - 2360 ft-lb
Working torque	<i>Coppia raccomandata</i>	1081-2433 Nm - 800-1800 ft-lb
Weight	<i>Peso</i>	7,5 kg - 16.5 lbs
Free speed	<i>Velocità libera</i>	6000 rpm
Impacts number	<i>Numero impatti</i>	950/min
Working pressure	<i>Pressione di utilizzo</i>	6.3 bar - 91 psi
Air inlet	<i>Ingresso aria</i>	1/2" NPT
Inner hose diameter	<i>Diametro interno tubo</i>	13 mm - 0.512 in
Length (with short anvil)	<i>Lunghezza (con albero corto)</i>	490 mm - 20 in
Side to center	<i>Ingombro centro lato</i>	55,5 mm - 2.18 in
Vibration level - triaxial	<i>Livello vibrazioni - triassiale</i>	12,4 m/s ²
Sound pressure level	<i>Pressione sonora</i>	102 dB(A)



INCLUDED IN THE BOX INCLUSI NELLA SCATOLA



The package contains: grease for hammer mechanism, oil for impact wrench motors, operating and maintenance manual, after-sales suggestions.

La confezione contiene: grasso per masse battenti, olio per i motori degli avvitatori, manuale d'uso e manutenzione, indicazioni post-vendita.

MAIN FEATURES CARATTERISTICHE PRINCIPALI

HAMMER MECHANISM TIPO MASSE BATTENTI



Twin hammer
Doppio martello

ANVIL TYPE TIPO ALBERO



With ring, with hole
Con anello, con foro

AIR EXHAUST DIRECTION DIREZIONE SCARICO ARIA



Through the handle
Impugnatura

HAMMER MECHANISM LUBRICATION LUBRIFICAZIONE MASSE BATTENTI



Grease
Grasso

BEST FOR APPLICAZIONI



Mobile workshops
Officine mobili



Infrastructures
Infrastrutture



Heavy vehicles
Mezzi pesanti



AVAILABLE DISPONIBILE

DP 3700 AL - 003700.00002

ANVIL LENGTH	198,7 mm
LUNGHEZZA ALBERO	7.82 in

WEIGHT	8,5 kg
PESO	18.7 lbs

DP 3800

PROFESSIONAL RANGE

1"



Product code	<i>Codice prodotto</i>	003800.00002
Square drive	<i>Attacco quadro</i>	1"
Bolt range	<i>Capacità bullone</i>	M18-M39
Max torque	<i>Coppia massima</i>	3000 Nm - 2220 ft-lb
Working torque	<i>Coppia raccomandata</i>	450-2440 Nm - 330-1800 ft-lb
Weight	<i>Peso</i>	11,5 kg - 25.3 lbs
Free speed	<i>Velocità libera</i>	3600 rpm
Impacts number	<i>Numero impatti</i>	830/min
Working pressure	<i>Pressione di utilizzo</i>	6,3 bar - 91 psi
Air inlet	<i>Ingresso aria</i>	1/2" NPT
Inner hose diameter	<i>Diametro interno tubo</i>	13 mm - 0.512 in
Length (with short anvil)	<i>Lunghezza (con albero corto)</i>	401,5 mm - 15.8 in
Side to center	<i>Ingombro centro lato</i>	59,5 mm - 2.34 in
Vibration level - triaxial	<i>Livello vibrazioni - triassiale</i>	6,1 m/s ²
Sound pressure level	<i>Pressione sonora</i>	102 dB(A)



INCLUDED IN THE BOX INCLUSI NELLA SCATOLA



The package contains: grease for hammer mechanism, oil for impact wrench motors, operating and maintenance manual, after-sales suggestions.

La confezione contiene: grasso per masse battenti, olio per i motori degli avvitatori, manuale d'uso e manutenzione, indicazioni post-vendita.

MAIN FEATURES CARATTERISTICHE PRINCIPALI

HAMMER MECHANISM TIPO MASSE BATTENTI



Twin hammer
Doppio martello

ANVIL TYPE TIPO ALBERO



With ring, with hole
Con anello, con foro

AIR EXHAUST DIRECTION DIREZIONE SCARICO ARIA



Through the handle
Impugnatura

HAMMER MECHANISM LUBRICATION LUBRIFICAZIONE MASSE BATTENTI



Grease
Grasso

BEST FOR APPLICAZIONI



Construction site and shipyard
Cantieri e costruzioni navali



Heavy vehicles
Mezzi pesanti



Infrastructures
Infrastrutture

AVAILABLE DISPONIBILE

DP 3800 AL - 003800.00001

ANVIL LENGTH 151 mm
LUNGHEZZA ALBERO 5.95 in

WEIGHT 11,9 kg
PESO 26.2 lbs



003800.00005

AVAILABLE DISPONIBILE

Threaded exhaust adapter for Paoli Trolley to direct the outgoing air
Adattatore per carrelli Paoli per scarico filettato per canalizzare l'aria in uscita



DP 256 BG

HEAVY DUTY RANGE

1"



Product code	<i>Codice prodotto</i>	0256BG.00001
Square drive	<i>Attacco quadro</i>	1"
Bolt range	<i>Capacità bullone</i>	M18-M39
Max torque	<i>Coppia massima</i>	3200 Nm - 2360 ft-lb
Working torque	<i>Coppia raccomandata</i>	600-2200 Nm - 450-1610 ft-lb
Weight	<i>Peso</i>	9,4 kg - 20.9 lbs
Free speed	<i>Velocità libera</i>	3200 rpm
Impacts number	<i>Numero impatti</i>	750/min
Working pressure	<i>Pressione di utilizzo</i>	6,3 bar - 91 psi
Air inlet	<i>Ingresso aria</i>	1/2" BSP
Inner hose diameter	<i>Diametro interno tubo</i>	16 mm - 0.630 in
Length (with short anvil)	<i>Lunghezza (con albero corto)</i>	357 mm - 14.05 in
Side to center	<i>Ingombro centro lato</i>	56 mm - 2.2 in
Vibration level - triaxial	<i>Livello vibrazioni - triassiale</i>	4,9 m/s ²
Sound pressure level	<i>Pressione sonora</i>	101dB(A)



INCLUDED IN THE BOX INCLUSI NELLA SCATOLA



The package contains: lifting eye bolt, handle kit (in compliance with the CE UNI EN ISO 11148-6 norm), grease for hammer mechanism, oil for impact wrench motors, 4 socket head cap screws, 4 lock washers, 2 front gaskets (0,1 mm - 0,2 mm), operating and maintenance manual, after-sales suggestions.

La confezione contiene: golfare, kit maniglia (in conformità con la normativa CE UNI EN ISO 11148-6), grasso per masse battenti, olio per i motori degli avvitatori, 4 viti a testa cilindrica, 4 rondelle di sicurezza, 2 guarnizioni anteriori (0,1 mm - 0,2 mm), manuale d'uso e manutenzione, indicazioni post-vendita.

MAIN FEATURES CARATTERISTICHE PRINCIPALI

HAMMER MECHANISM TIPO MASSE BATTENTI



3-jaw
3 griffe

ANVIL TYPE TIPO ALBERO



With ring, with hole
Con anello, con foro

AIR EXHAUST DIRECTION DIREZIONE SCARICO ARIA



Air exhaust direction: frontal
Direzione scarico aria: frontale

HAMMER MECHANISM LUBRICATION LUBRIFICAZIONE MASSE BATTENTI



Grease
Grasso

BEST FOR APPLICAZIONI



Heavy vehicles
Mezzi pesanti



infrastructures
Infrastrutture



Railways applications
Applicazioni ferroviarie



Construction site and shipyard
Cantieri e costruzioni navali



Usable with Paoli Mobile Working Stations
Utilizzabile con Postazione di Lavoro Mobile Paoli

7075 aluminium (ergal) front cover
Cover anteriore in alluminio 7075 (ergal)

Upgraded 3-jaw hammer mechanism
Masse battenti a 3 griffe perfezionate

SAFETY SHIELD

Available (page 232)

THE CLASSIC "STRAIGHT" 1" SQUARE DRIVE MODEL IL MODELLO TRADIZIONALE CON IMPUGNATURA DIRITTA E ATTACCO QUADRO DA 1"

PERFORMANCE PRESTAZIONI



Sensible torque increase over 5"
Aumento di coppia sensibile oltre i 5"

Resistance over 7 bar
Resistenza oltre i 7 bar

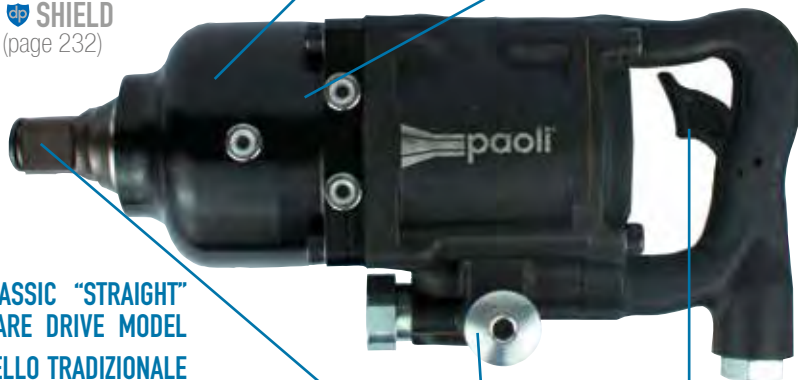

Side inverter
Invertitore laterale

Inner and safe trigger
Leva di avviamento
interna e sicura



Available with power register on demand
Disponibile con registro di potenza su
richiesta

AVAILABLE DISPONIBILE

DP 256 BG AL - 0256BG.00002

ANVIL LENGTH 137 mm
LUNGHEZZA ALBERO 5.4 in

WEIGHT 10,6 kg
PESO 23,4 lbs



DP 320

HEAVY DUTY RANGE

1"



Product code	<i>Codice prodotto</i>	000320.00037
Square drive	<i>Attacco quadro</i>	1"
Bolt range	<i>Capacità bullone</i>	M18-M45
Max torque	<i>Coppia massima</i>	3750 Nm - 2760 ft-lb
Working torque	<i>Coppia raccomandata</i>	800-2300 Nm - 600-1700 ft-lb
Weight	<i>Peso</i>	10,8 kg - 23.9 lbs
Free speed	<i>Velocità libera</i>	3000 rpm
Impacts number	<i>Numero impatti</i>	755/min
Working pressure	<i>Pressione di utilizzo</i>	6,3 bar - 91 psi
Air inlet	<i>Ingresso aria</i>	1/2" BSP
Inner hose diameter	<i>Diametro interno tubo</i>	16 mm - 0.630 in
Length (with short anvil)	<i>Lunghezza (con albero corto)</i>	275 mm - 10.83 in
Side to center	<i>Ingombro centro lato</i>	55 mm - 2.17 in
Vibration level - triaxial	<i>Livello vibrazioni - triassiale</i>	5,8 m/s ²
Sound pressure level	<i>Pressione sonora</i>	103 dB(A)



INCLUDED IN THE BOX INCLUSI NELLA SCATOLA



The package contains: handle kit (in compliance with the CE UNI EN ISO 11148-6 norm), grease for hammer mechanism, oil for impact wrench motors, 4 socket head cap screws, 4 lock washers, 2 front gaskets (0,1 mm - 0,2 mm), operating and maintenance manual, after-sales suggestions.

La confezione contiene: kit maniglia (in conformità con la normativa CE UNI EN ISO 11148-6), grasso per masse battenti, olio per i motori degli avvitatori, 4 viti a testa cilindrica, 4 rondelle di sicurezza, 2 guarnizioni anteriori (0,1 mm - 0,2 mm), manuale d'uso e manutenzione, indicazioni post-vendita.

MAIN FEATURES

CARATTERISTICHE PRINCIPALI

HAMMER MECHANISM

TIPO MASSE BATTENTI



3-jaw
3 griffe

ANVIL TYPE

TIPO ALBERO



With ring, with hole
Con anello, con foro

AIR EXHAUST DIRECTION

DIREZIONE SCARICO ARIA



Through the handle
Impugnatura

HAMMER MECHANISM LUBRICATION

LUBRIFICAZIONE MASSE BATTENTI



Grease
Grasso

BEST FOR

APPLICAZIONI



Heavy vehicles
Mezzi pesanti



Infrastructures
Infrastrutture



Mechanical workshops
Officine meccaniche



Construction site and shipyard
Cantieri e costruzioni navali



Industrial assembly
Montaggi industriali

THE MOST POWERFUL MODEL 1" SQUARE DRIVE FOR AUTOMOTIVE IL MODELLO DA 1" PIÙ POTENTE PER IL SETTORE AUTOMOTIVE



SAFETY SHIELD

Available (page 232)

AVAILABLE DISPONIBILE

DP 320 AL - 000320.00041

ANVIL LENGTH 155 mm
LUNGHEZZA ALBERO 6.1 in

WEIGHT 12,1 kg
PESO 26.8 lbs

PERFORMANCE PRESTAZIONI



Sensible torque increase over 5"
Aumento di coppia sensibile oltre i 5"

Resistance over 7 bar
Resistenza oltre i 7 bar

Air exhaust through the handle
• less noise
• no harmful dust

Scarico dell'aria esausta
nell'impugnatura

• minore rumorosità
• assenza di polveri nocive

Available with power register on demand
Disponibile con registro di potenza su
richiesta

paoli

DP 321

HEAVY DUTY RANGE

1 1/2"



Product code	<i>Codice prodotto</i>	000321.00005
Square drive	<i>Attacco quadro</i>	1 1/2"
Bolt range	<i>Capacità bullone</i>	M20-M50
Max torque	<i>Coppia massima</i>	4450 Nm - 3270 ft-lb
Working torque	<i>Coppia raccomandata</i>	1000-2500 Nm - 730-1850 ft-lb
Weight	<i>Peso</i>	11,3 kg - 25 lbs
Free speed	<i>Velocità libera</i>	3.000 rpm
Impacts number	<i>Numero impatti</i>	755/min
Working pressure	<i>Pressione di utilizzo</i>	6,3 bar - 91 psi
Air inlet	<i>Ingresso aria</i>	1/2" BSP
Inner hose diameter	<i>Diametro interno tubo</i>	16 mm - 0.630 in
Length	<i>Lunghezza</i>	285 mm - 11.22 in
Side to center	<i>Ingombro centro lato</i>	55 mm - 2.17 in
Vibration level - triaxial	<i>Livello vibrazioni - triassiale</i>	11 m/s ²
Sound pressure level	<i>Pressione sonora</i>	102 dB(A)



INCLUDED IN THE BOX INCLUSI NELLA SCATOLA



The package contains: handle kit (in compliance with the CE UNI EN ISO 11148-6 norm), grease for hammer mechanism, oil for impact wrench motors, 4 socket head cap screws, 4 lock washers, 2 front gaskets (0,1 mm - 0,2 mm), operating and maintenance manual, after-sales suggestions.

La confezione contiene: kit maniglia (in conformità con la normativa CE UNI EN ISO 11148-6), grasso per masse battenti, olio per i motori degli avvitatori, 4 viti a testa cilindrica, 4 rondelle di sicurezza, 2 guarnizioni anteriori (0,1 mm - 0,2 mm), manuale d'uso e manutenzione, indicazioni post-vendita.

MAIN FEATURES CARATTERISTICHE PRINCIPALI

HAMMER MECHANISM TIPO MASSE BATTENTI



3-jaw
3 griffe

ANVIL TYPE TIPO ALBERO



With hole, without ring
Con foro, senza anello

AIR EXHAUST DIRECTION DIREZIONE SCARICO ARIA



Through the handle
Impugnatura

HAMMER MECHANISM LUBRICATION LUBRIFICAZIONE MASSE BATTENTI



Grease
Grasso

BEST FOR APPLICAZIONI



Usable with Paoli Mobile Working Stations
Utilizzabile con Postazione di Lavoro Mobile Paoli



Construction site and shipyard
Cantieri e costruzioni navali



Infrastructures
Infrastrutture



Railways applications
Applicazioni ferroviarie

1 1/2" SQUARE DRIVE MODEL FOR LIGHT USES MODELLO DA 1 1/2" PER UTILIZZI LEGGERI



The 1 1/2" square drive model with pistol grip and rear exhaust
Il modello con attacco quadro da 1 1/2" con impugnatura a pistola e scarico posteriore.

Air exhaust through the handle

- less noise
- no harmful dust

Scarico dell'aria esausta nell'impugnatura

- minore rumorosità
- assenza di polveri nocive

Available with power register on demand
Disponibile con registro di potenza su richiesta

PERFORMANCE PRESTAZIONI



Sensible torque increase over 5"
Aumento di coppia sensibile oltre i 5"

Resistance over 7 bar
Resistenza oltre i 7 bar



DP 362 BG

HEAVY DUTY RANGE

1" - 1 1/2"



Product code	<i>Codice prodotto</i>	0362BG.00001
Square drive	<i>Attacco quadro</i>	1 1/2"
Bolt range	<i>Capacità bullone</i>	M24-M56
Max torque	<i>Coppia massima</i>	5950 Nm - 4400 ft-lb
Working torque	<i>Coppia raccomandata</i>	1400-3300 Nm - 1050-2440 ft-lb
Weight	<i>Peso</i>	14,5 kg - 32 lbs
Free speed	<i>Velocità libera</i>	3200 rpm
Impacts number	<i>Numero impatti</i>	650/min
Working pressure	<i>Pressione di utilizzo</i>	6,3 bar - 91 psi
Air inlet	<i>Ingresso aria</i>	1/2" BSP
Inner hose diameter	<i>Diametro interno tubo</i>	16 mm - 0.630 in
Length	<i>Lunghezza</i>	421 mm - 16.6 in
Side to center	<i>Ingombro centro lato</i>	62 mm - 2.45 in
Vibration level - triaxial	<i>Livello vibrazioni - triassiale</i>	12,3 m/s ²
Sound pressure level	<i>Pressione sonora</i>	104 dB(A)



INCLUDED IN THE BOX INCLUSI NELLA SCATOLA



The package contains: handle kit (in compliance with the CE UNI EN ISO 11148-6 norm), lifting eye bolt, grease for hammer mechanism, oil for impact wrench motors, 4 socket head cap screws, 4 lock washers, 2 front gaskets (0,1 mm - 0,2 mm), operating and maintenance manual, after-sales suggestions.

La confezione contiene: kit maniglia (in conformità con la normativa CE UNI EN ISO 11148-6), golfare, grasso per masse battenti, olio per i motori degli avvitatori, 4 viti a testa cilindrica, 4 rondelle di sicurezza, 2 guarnizioni anteriori (0,1 mm - 0,2 mm), manuale d'uso e manutenzione, indicazioni post-vendita.

MAIN FEATURES CARATTERISTICHE PRINCIPALI

HAMMER MECHANISM TIPO MASSE BATTENTI



3-jaw
3 griffe

ANVIL TYPE TIPO ALBERO



Without ring, with hole
Senza anello, con foro

AIR EXHAUST DIRECTION DIREZIONE SCARICO ARIA



Frontal
Frontale

HAMMER MECHANISM LUBRICATION LUBRIFICAZIONE MASSE BATTENTI



Grease
Grasso

BEST FOR APPLICAZIONI



Industrial assembly
Montaggi industriali



Infrastructures
Infrastrutture



Railways applications
Applicazioni ferroviarie



Construction site and shipyard
Cantieri e costruzioni navali



Usable with Paoli Mobile Working Stations
Utilizzabile con Postazione di Lavoro Mobile Paoli

BEST SELLER PRODUCT PRODOTTO BEST SELLER

Upgraded 3-jaw hammer mechanism
Masse battenti a 3 griffe perfezionate.

Ergal cover
• lighter
• more shock resistant

Cuffia in ergal
• più leggera
• più resistente agli urti e agli sforzi

PERFORMANCE PRESTAZIONI



Sensible torque increase over 5"
Aumento di coppia sensibile oltre i 5"

Resistance over 7 bar
Resistenza oltre i 7 bar

SAFETY SHIELD
Available (page 232)

Ergonomic handle
Impugnatura ergonomica



Available with power register on demand
Disponibile con registro di potenza su richiesta

AVAILABLE: 1" VERSION
DISPONIBILE: VERSIONE DA 1"

DP 362 BG 1" - 0362BG.00002

BOLT RANGE CAPACITÀ BULLONE	M18-M56
MAX TORQUE COPPIA MASSIMA	5297 Nm 3920 ft-lb
WORKING TORQUE COPPIA RACCOMANDATA	1177-2943 Nm 871-2178 ft-lb
LENGTH LUNGHEZZA	413 mm 16.25 in
WEIGHT PESO	14,3 kg 31.7 lbs

DP 382

HEAVY DUTY RANGE

1 1/2"



Product code	<i>Codice prodotto</i>	000382.00001
Square drive	<i>Attacco quadro</i>	1 1/2"
Bolt range	<i>Capacità bullone</i>	M30-M80
Max torque	<i>Coppia massima</i>	14000 Nm - 10325 ft-lb
Working torque	<i>Coppia raccomandata</i>	3150-9900 Nm - 2320-7300 ft-lb
Weight	<i>Peso</i>	39,9 kg - 87.9 lbs
Free speed	<i>Velocità libera</i>	2300 rpm
Impacts number	<i>Numero impatti</i>	515/min
Working pressure	<i>Pressione di utilizzo</i>	6,3 bar - 91 psi
Air inlet	<i>Ingresso aria</i>	3/4" BSP
Inner hose diameter	<i>Diametro interno tubo</i>	19 mm - 0.748 in
Length	<i>Lunghezza</i>	515 mm - 20.28 in
Side to center	<i>Ingombro centro lato</i>	88,5 mm - 3.48 in
Vibration level - triaxial	<i>Livello vibrazioni - triassiale</i>	11,9 m/s ²
Sound pressure level	<i>Pressione sonora</i>	106 dB(A)



INCLUDED IN THE BOX INCLUSI NELLA SCATOLA



The package contains: barb 3/4", grease for hammer mechanism, oil for impact wrench motors, 8 socket head cap screws, 8 lock washers, front gasket, operating and maintenance manual, after-sales suggestions.

La confezione contiene: resca 3/4", grasso per masse battenti, olio per i motori degli avvitatori, 8 viti a testa cilindrica, 8 rondelle di sicurezza, guarnizione anteriore, manuale d'uso e manutenzione, indicazioni post-vendita.

MAIN FEATURES CARATTERISTICHE PRINCIPALI

HAMMER MECHANISM TIPO MASSE BATTENTI



3-jaw
3 griffe

ANVIL TYPE TIPO ALBERO



Without ring, with hole
Senza anello, con foro

AIR EXHAUST DIRECTION DIREZIONE SCARICO ARIA



Through the handle
Impugnatura

HAMMER MECHANISM LUBRICATION LUBRIFICAZIONE MASSE BATTENTI



Grease
Grasso

BEST FOR APPLICAZIONI



Industrial assembly
Montaggi industriali



Infrastructures
Infrastrutture



Railways applications
Applicazioni ferroviarie



Construction site and shipyard
Cantieri e costruzioni navali

NEW MODEL! NUOVO MODELLO!



Extreme durability
Estrema durabilità

Optimized performance
Prestazioni ottimizzate

Aluminium body
Corpo in alluminio

One of the most powerful impact
wrench of these T-handle models
range
*Uno dei più potenti avvitatori della
gamma con impugnatura a T*

DP 635

HEAVY DUTY RANGE

2" - 2 1/2"



Product code	<i>Codice prodotto</i>	000635.00001
Square drive	<i>Attacco quadro</i>	2 1/2"
Bolt range	<i>Capacità bullone</i>	M50-M110
Max torque	<i>Coppia massima</i>	26400 Nm - 19520 ft-lb
Working torque	<i>Coppia raccomandata</i>	6050-8800 Nm - 4480-6510 ft-lb
Weight	<i>Peso</i>	67 kg - 147.7 lbs
Free speed	<i>Velocità libera</i>	2100 rpm
Impacts number	<i>Numero impatti</i>	400/min
Working pressure	<i>Pressione di utilizzo</i>	6,3 bar - 91 psi
Air inlet	<i>Ingresso aria</i>	1" BSP
Inner hose diameter	<i>Diametro interno tubo</i>	25 mm - 0.984 in
Length	<i>Lunghezza</i>	632,1 mm - 24.88 in
Side to center	<i>Ingombro centro lato</i>	95,5 mm - 3.76 in
Vibration level - triaxial	<i>Livello vibrazioni - triassiale</i>	13,7 m/s ²
Sound pressure level	<i>Pressione sonora</i>	114 dB(A)



INCLUDED IN THE BOX INCLUSI NELLA SCATOLA



The package contains: lifting eye bolt, handle kit (in compliance with the CE UNI EN ISO 11148-6 norm), grease for hammer mechanism, oil for impact wrench motors, 4 socket head cap screws, 4 lock washers, 2 front gaskets (0,1 mm - 0,2 mm), operating and maintenance manual, after-sales suggestions.

La confezione contiene: golfare, kit maniglia (in conformità con la normativa CE UNI EN ISO 11148-6), grasso per masse battenti, olio per i motori degli avvitatori, 4 viti a testa cilindrica, 4 rondelle di sicurezza, 2 guarnizioni anteriori (0,1 mm - 0,2 mm), manuale d'uso e manutenzione, indicazioni post-vendita.

MAIN FEATURES**CARATTERISTICHE PRINCIPALI****HAMMER MECHANISM***TIPO MASSE BATTENTI*3-jaw
3 griffe**ANVIL TYPE***TIPO ALBERO*With hole, without ring
Con foro, senza anello**AIR EXHAUST DIRECTION***DIREZIONE SCARICO ARIA*Through the handle
Impugnatura**HAMMER MECHANISM LUBRICATION***LUBRIFICAZIONE MASSE BATTENTI*Grease
Grasso**BEST FOR****APPLICAZIONI**Industrial assembly
Montaggi industrialiConstruction site and shipyard
Cantieri e costruzioni navaliInfrastructures
InfrastruttureRailways applications
Applicazioni ferroviarie**AVAILABLE: 2" VERSION**
DISPONIBILE: VERSIONE DA 2"

DP 635 2" - 000635.00002

MAX TORQUE 23544 Nm
COPPIA MASSIMA 17423 ft-lb**WORKING TORQUE** 5396-7848 Nm
COPPIA RACCOMANDATA 3993- 5808 ft-lb**LENGTH** 640,1 mm
LUNGHEZZA 25.2 inExtreme durability
*Estrema durabilità*The biggest and strongest
T-handle model
*Il più grande e robusto
modello con impugnatura a T*

AIRTOOLS

Paoli Air tools constitute a range of modern products specific for the demands of the market. These compact pneumatic tools completing the tightening ranges already developed by the company. Paoli Air Tools products have a variable speed trigger, a 360° swivel exhaust and an extra large ratchet head that provides increased strength and reliability. The ergonomically designed contoured handle and trigger provide ultimate operating comfort.

UTENSILI PNEUMATICI

Paoli Air tools è una gamma di prodotti moderni e adeguati alle richieste del mercato.

Utensili pneumatici compatti che si integrano alle gamme per l'avvitamento già sviluppate dall'azienda. I prodotti Paoli Air tools dispongono di una leva di avviamento a velocità variabile, uno scarico girevole a 360° e una testa a cricchetto extra-large che ne aumenta la forza e l'affidabilità. L'impugnatura e il grilletto sagomati, progettati ergonomicamente, garantiscono il massimo comfort di funzionamento.



AIRTOOLS UTENSILI PNEUMATICI

RATCHET WRENCHES

CHIAVI A CRICCHETTO

DP 7200



DP 7200

- Compact
Compatto
- No. 4 speed levels (adjustable)
N. 4 livelli di velocità (regolabili)
- Ergonomic handle
Impugnatura ergonomica

DP 9600



DP 9600

- Variable speed trigger
Leva di avviamento a velocità variabile
- 360° swivel exhaust
Scarico girevole a 360°
- REACTIONLESS impact mechanism inside
Meccanismo di impatto REACTIONLESS all'interno

DP 9300



DP 9300

- Ultra duty
Ultra-resistente
- 360° swivel exhaust
Scarico girevole a 360°
- Composite contour comfort grip
Impugnatura comfort rivestita in materiale composito

Product name	Nome prodotto	DP 7200	DP 9600	DP 9300
Product code	Codice prodotto	007200.00001	009600.00001	009300.00001
Square drive	Attacco quadro	3/8"	1/2"	1/2"
Bolt range	Capacità bullone	10 mm	13 mm	13 mm
Inner hose diameter	Diametro interno tubo	9,5 mm - 3/8"	9,5 mm - 3/8"	9,5 mm - 3/8"
Max torque	Coppia massima	47 Nm - 35 ft-lb	95 Nm - 70 ft-lb	189 Nm - 140 ft-lb
Working torque	Coppia raccomandata	40 Nm - 30 ft-lb	75 Nm - 55 ft-lb	162 Nm - 120 ft-lb
Working pressure	Pressione di utilizzo	6,3 bar - 90 psi	6,3 bar - 90 psi	6,3 bar - 90 psi
Free speed	Velocità libera	300 rpm	300 rpm	200 rpm
Weight	Peso	0,5 kg	1,35 kg	1,5 kg
Length	Lunghezza	165 mm - 6.1 in	310 mm - 12.1 in	316 mm - 12.2 in

DP 2250



DP 2250

- Heavy duty air grinder
Smerigliatrice pneumatica per utilizzi pesanti
- Two front bearing
Due cuscinetti anteriori
- Adjustable side exhaust
Scarico laterale regolabile

DP 2400



DP 2400

- Heavy duty air grinder
Smerigliatrice pneumatica per utilizzi pesanti
- Increased life span of 2,5 times
Durata aumentata di 2,5 volte
- Adjustable side exhaust
Scarico laterale regolabile

DP 2450



DP 2450

- Heavy duty air grinder - Extended 5"
Smerigliatrice pneumatica per utilizzi pesanti - Modello lungo: 5"
- Two front bearing
Due cuscinetti anteriori
- Adjustable side exhaust
Scarico laterale regolabile

Product name	Nome prodotto	DP 2250	DP 2400	DP 2450
Product code	Codice prodotto	002250.00001 (6 mm) 002250.00002 (1/4")	002400.00001 (6 mm) 002400.00002 (1/4")	002450.00001 (6 mm) 002450.00002 (1/4")
Collect Capacity	Dimensione attacco	6 mm - 1/4"	6 mm - 1/4"	6 mm - 1/4"
Air inlet	Ingresso aria	1/4"	1/4"	1/4"
Inner hose diameter	Diametro interno tubo	9,5 mm - 3/8"	9,5 mm - 3/8"	9,5 mm - 3/8"
Working pressure	Pressione di utilizzo	6,3 bar - 90 psi	6,3 bar - 90 psi	6,3 bar - 90 psi
Power	Potenza	372 w	372 w	372 w
Free speed	Velocità libera	20.000 rpm	14.000 rpm	18.000 rpm
Weight	Peso	0,62 kg	0,73 kg	0,93 kg
Length	Lunghezza	188 mm - 7.3 in	185 mm - 7.2 in	303 mm - 11.8 in

DP 9500

DP 9500

- 7" wheel size
Diametro disco: 7"

DP 9860

DP 9860

- New motor design, even more powerful!
Nuovo design del motore, ancora più potente!
- Ergonomic handle
Impugnatura ergonomica
- Swivel exhaust
Scarico girevole

DP 4500

DP 4500

- Fast and reliable
Veloce e affidabile
- Ergonomic handle
Impugnatura ergonomica
- Twin hammer-system
Sistema a doppio martello

Product name	<i>Nome prodotto</i>	DP 9500
Product code	<i>Codice prodotto</i>	009500.00001
Grinding wheel size	<i>Diametro disco</i>	180 mm - 7"
Square drive	<i>Attacco quadro</i>	--
Air inlet	<i>Ingresso aria</i>	3/8"
Inner hose diameter	<i>Diametro interno tubo</i>	9,5 mm - 3/8"
Max torque	<i>Coppia massima</i>	--
Working torque	<i>Coppia raccomandata</i>	--
Working pressure	<i>Pressione di utilizzo</i>	6,3 bar - 90 psi
Power	<i>Potenza</i>	1715 w
Free speed	<i>Velocità libera</i>	7.600 rpm
Weight	<i>Peso</i>	2,0 kg
Length	<i>Lunghezza</i>	231 mm - 9.1 in

Product name	<i>Nome prodotto</i>	DP 9860
Product code	<i>Codice prodotto</i>	009860.00001
Grinding wheel size	<i>Diametro disco</i>	--
Square drive	<i>Attacco quadro</i>	1/2"
Air inlet	<i>Ingresso aria</i>	1/4"
Inner hose diameter	<i>Diametro interno tubo</i>	9,5 mm - 3/8"
Max torque	<i>Coppia massima</i>	540 Nm - 400 ft-lb
Working torque	<i>Coppia raccomandata</i>	100-300 Nm (74 - 221 ft-lb)
Working pressure	<i>Pressione di utilizzo</i>	6,3 bar - 90 psi
Power	<i>Potenza</i>	--
Free speed	<i>Velocità libera</i>	8500 rpm
Weight	<i>Peso</i>	1,35 kg
Length	<i>Lunghezza</i>	92 mm - 3.6 in

Product name	<i>Nome prodotto</i>	DP 4500
Product code	<i>Codice prodotto</i>	004500.00001
Grinding wheel size	<i>Diametro disco</i>	--
Square drive	<i>Attacco quadro</i>	1/4"
Air inlet	<i>Ingresso aria</i>	1/4"
Inner hose diameter	<i>Diametro interno tubo</i>	9,5 mm - 3/8"
Max torque	<i>Coppia massima</i>	68 Nm - 50 ft-lb
Working torque	<i>Coppia raccomandata</i>	40 Nm - 30 ft-lb
Working pressure	<i>Pressione di utilizzo</i>	6,3 bar - 90 psi
Power	<i>Potenza</i>	--
Free speed	<i>Velocità libera</i>	13.000 rpm
Weight	<i>Peso</i>	0,65 kg
Length	<i>Lunghezza</i>	166 mm - 6.5 in



ACCESSORI INCLUSI

- 1 Impact wrench
1 avvitatore
- 1 1/4" Sockets 8 mm (L=50 mm)
1 bussola 1/4" 8 mm (L=50 mm)
- 1 1/4" Sockets 9 mm (L=50 mm)
1 bussola 1/4" 9 mm (L=50 mm)
- 1 1/4" Sockets 10 mm (L=50 mm)
1 bussola 1/4" 10 mm (L=50 mm)
- 1 1/4" Sockets 11 mm (L=50 mm)
1 bussola 1/4" 11 mm (L=50 mm)
- 1 1/4" Sockets 12 mm (L=50 mm)
1 bussola 1/4" 12 mm (L=50 mm)
- 1 1/4" Sockets 13 mm (L=50 mm)
1 bussola 1/4" 13 mm (L=50 mm)
- 1 1/4" 50 mm Ext. Bar
1 barra di estensione 1/4" 50 mm
- 1 1/4" 125 mm Ext.Bar
1 barra di estensione 1/4" 125 mm
- 1 1/4" Universal Joint
1 giunto universale 1/4"
- 1 1/4" Air Inlet
1 ingresso aria 1/4"

ELECTRIC RANGE T7 BATTERIES

Paoli cordless impact wrenches are the ideal solution in all situations where compressed air is not available.

Light and reliable, they are powered by a 20,0 V D.C. lithium ion battery.

Suggested to be used in garages, tyreshops and a wide range of industrial applications, they are supplied in a hard case with a spare battery and a charger.

Advantages:

- Freedom of movement
- Speed and power
- Comfort and ergonomics for the operator
- Ease of use

GAMMA ELETTRICA BATTERIE T7

Gli avvitatori a batteria Paoli sono la soluzione ideale in tutti i casi in cui non è disponibile aria compressa.

Leggeri e affidabili, sono alimentati da una batteria agli ioni di litio da 20,0 V. D.C.

Consigliati per un utilizzo garage, per i gommisti e per molteplici applicazioni industriali, sono forniti in una custodia rigida con una batteria di ricambio e un caricatore.

Vantaggi:

- *Libertà di movimento*
- *Velocità e potenza*
- *Comfort ed ergonomia per l'operatore*
- *Facilità d'utilizzo*



ELECTRIC RANGE T7 BATTERIES
GAMMA ELETTRICA CON BATTERIE T7

TOOLKIT

ELECTRIC RANGE

1/4"



Product code	<i>Codice prodotto</i>	A.08.0030
Square drive	<i>Attacco quadro</i>	1/4"
Weight with battery	<i>Peso con batteria</i>	0,88 kg (1.94 lbs)
Length	<i>Lunghezza</i>	158 mm (6.22")
Width	<i>Larghezza</i>	54 mm (2")
Height	<i>Altezza</i>	216 mm (8.50")
Voltage	<i>Voltaggio</i>	10.8V d.c.
Max torque	<i>Coppia massima</i>	23.5 Nm (17 ft-lbs)
Free speed	<i>Velocità libera</i>	1550 rpm
Amperage	<i>Amperaggio</i>	2.0 Ah



INCLUDED IN THE BOX INCLUSI NELLA SCATOLA



The package contains: charger, 2 batteries, operating and maintenance manual, after-sales suggestions.

La confezione contiene: caricabatterie, 2 batterie, manuale d'uso e manutenzione, indicazioni post-vendita.

AVAILABLE PACKAGES PACCHETTI DISPONIBILI

FULL PACKAGE - A.08.0030
PACCHETTO COMPLETO - A.08.0030



The package includes:

- Cordless impact wrench
- 2 batteries 2.0 Ah
- Hard case
- Battery charger

Il pacchetto include:

- Avvitatore cordless
- 2 batterie 2.0 Ah
- Custodia rigida
- Caricabatterie

STANDARD PACKAGE PACCHETTO STANDARD



The package includes:

- Cordless impact wrench (A.08.0039)
- 1 battery
- Optional: 2nd battery

Il pacchetto include:

- Avvitatore cordless (A.08.0039)
- 1 batteria
- Opzionale: seconda batteria

Battery Models	Product Code
2.0Ah	B.50.0016

BASIC PACKAGE PACCHETTO BASIC



The package includes:

- Cordless impact wrench without battery (A.08.0039)

Il pacchetto include:

- Avvitatore cordless senza batteria (A.08.0039)

BEST FOR APPLICAZIONI



Cars, van, suv tyreshops
Gommisti vetture, van, suv



Lighter and more compact!
Più leggero e compatto!

Ergonomic handle
Impugnatura ergonomica

Lithium ion battery 10.8V D.C.
Batteria agli ioni di litio 10.8V D.C.

STORM BRUSHLESS

ELECTRIC RANGE

1/2"



Product code	<i>Codice prodotto</i>	A.08.0012
Square drive	<i>Attacco quadro</i>	1/2"
Weight with battery	<i>Peso con batteria</i>	1,66 kg - 3.66 lbs
Length	<i>Lunghezza</i>	154 mm - 6.06 in
Width	<i>Larghezza</i>	76 mm - 3 in
Height	<i>Altezza</i>	239 mm - 9.41 in
Voltage	<i>Voltaggio</i>	20,0V d.c.
Max torque	<i>Coppia massima</i>	350 Nm - 260 ft-lbs
Free speed	<i>Velocità libera</i>	2300 rpm
Amperage	<i>Amperaggio</i>	5.0/6.0 Ah



INCLUDED IN THE BOX INCLUSI NELLA SCATOLA



The package contains: charger, 2 batteries, operating and maintenance manual, after-sales suggestions.

La confezione contiene: caricabatterie, 2 batterie, manuale d'uso e manutenzione, indicazioni post-vendita.

AVAILABLE PACKAGES PACCHETTI DISPONIBILI

FULL PACKAGE - A.08.0012
PACCHETTO COMPLETO - A.08.0012



The package includes:

- Cordless impact wrench
- 2 batteries - 5/6 Ah
- Hard case
- Battery charger

Il pacchetto include:

- Avvitatore cordless
- 2 batterie - 5/6 Ah
- Custodia rigida
- Caricabatterie

STANDARD PACKAGE PACCHETTO STANDARD



The package includes:

- Cordless impact wrench (A.08.0013)
- 1 battery
- Optional: 2nd battery

Il pacchetto include:

- Avvitatore cordless (A.08.0013)
- 1 batteria
- Opzionale: seconda batteria

Battery Models	Product Code
5.0Ah	B.50.0009
6.0Ah	B.50.0010

BASIC PACKAGE PACCHETTO BASIC



The package includes:

- Cordless impact wrench without battery (A.08.0013)

Il pacchetto include:

- Avvitatore cordless senza batteria (A.08.0013)

BEST FOR APPLICAZIONI



Industrial assembly
Montaggi industriali

NEW BRUSHLESS STORM!
+20% OF ENERGY SAVING!
NUOVO STORM BRUSHLESS!
+20% DI RISPARMIO DI ENERGIA!

AVAILABLE DISPONIBILE

STORM BRUSHED

Cordless impact wrench Avvitatore cordless	A.08.0005
Cordless impact wrench without battery Avvitatore cordless senza batteria	A.08.0008

Lithium ion battery 20.0 V D.C.
Batteria agli ioni di litio 20.0 V D.C.



Lighter and more compact
Più leggero e compatto

Brushless motor
Motore brushless

LED light
Luce a Led

Potentiometer
Potenziometro

Ergonomic handle
Impugnatura ergonomica

Battery level indicator
Indicatore di livello
batteria

ROCKET

ELECTRIC RANGE

1/2"



Product code	<i>Codice prodotto</i>	A.08.0004
Square drive	<i>Attacco quadro</i>	1/2"
Weight with battery	<i>Peso con batteria</i>	2,15 kg - 4.74 lbs
Length	<i>Lunghezza</i>	242 mm - 9.5 in
Width	<i>Larghezza</i>	80 mm - 3.1 in
Height	<i>Altezza</i>	255 mm - 10 in
Voltage	<i>Voltaggio</i>	20,0V d.c.
Max torque	<i>Coppia massima</i>	550 Nm - 400 ft-lbs
Free speed	<i>Velocità libera</i>	1650 rpm
Amperage	<i>Amperaggio</i>	5.0/6.0 Ah



INCLUDED IN THE BOX INCLUSI NELLA SCATOLA



The package contains: charger, 2 batteries, operating and maintenance manual, after-sales suggestions.

La confezione contiene: caricabatterie, 2 batterie, manuale d'uso e manutenzione, indicazioni post-vendita.

AVAILABLE PACKAGES PACCHETTI DISPONIBILI

FULL PACKAGE - A.08.0004
PACCHETTO COMPLETO - A.08.0004



The package includes:

- Cordless impact wrench
- 2 batteries - 5/6 Ah
- Hard case
- Battery charger

Il pacchetto include:

- Avvitatore cordless
- 2 batterie - 5/6 Ah
- Custodia rigida
- Caricabatterie

STANDARD PACKAGE PACCHETTO STANDARD



The package includes:

- Cordless impact wrench (A.08.0011)
- 1 battery
- Optional: 2nd battery

Il pacchetto include:

- Avvitatore cordless (A.08.0011)
- 1 batteria
- Opzionale: seconda batteria

Battery Models	Product Code
5.0Ah	B.50.0009
6.0Ah	B.50.0010

BASIC PACKAGE PACCHETTO BASIC



The package includes:

- Cordless impact wrench without battery (A.08.0011)

Il pacchetto include:

- Avvitatore cordless senza batteria (A.08.0011)

BEST FOR APPLICAZIONI



Industrial assembly
Montaggi industriali

Light and reliable
Leggero e affidabile

Ergonomic handle
Impugnatura ergonomica

Lithium ion battery 20.0 V D.C.
Batteria agli ioni di litio 20.0 V D.C.



Torque Selection System
Sistema di selezione della coppia

Battery level indicator
Indicatore di livello batteria

TYPHOON

ELECTRIC RANGE 1/2" - 3/4"



Product code	<i>Codice prodotto</i>	A.08.0006
Square drive	<i>Attacco quadro</i>	1/2"
Weight with battery	<i>Peso con batteria</i>	3,55 kg - 7.82 lbs
Length	<i>Lunghezza</i>	236 mm - 9.29 in
Width	<i>Larghezza</i>	84 mm - 3.3 in
Height	<i>Altezza</i>	278 mm - 10.94 in
Voltage	<i>Voltaggio</i>	20,0V d.c.
Max torque	<i>Coppia massima</i>	880 Nm - 650 ft-lbs
Free speed	<i>Velocità libera</i>	1650 rpm
Amperage	<i>Amperaggio</i>	5.0/6.0 Ah



INCLUDED IN THE BOX INCLUSI NELLA SCATOLA



The package contains: charger, 2 batteries, operating and maintenance manual, after-sales suggestions.

La confezione contiene: caricabatterie, 2 batterie, manuale d'uso e manutenzione, indicazioni post-vendita.

AVAILABLE PACKAGES PACCHETTI DISPONIBILI

FULL PACKAGE - A.08.0006
PACCHETTO COMPLETO - A.08.0006



The package includes:

- Cordless impact wrench
- 2 batteries - 5/6 Ah
- Hard case
- Battery charger

Il pacchetto include:

- Avvitatore cordless
- 2 batterie - 5/6 Ah
- Custodia rigida
- Caricabatterie

STANDARD PACKAGE PACCHETTO STANDARD



The package includes:

- Cordless impact wrench (1/2": A.08.0009 3/4": A.08.0010)
- 1 battery
- Optional: 2nd battery

Il pacchetto include:

- Avvitatore cordless (1/2": A.08.0009 3/4": A.08.0010)
- 1 batteria
- Opzionale: seconda batteria

Battery Models	Product Code
5.0Ah	B.50.0009
6.0Ah	B.50.0010

BASIC PACKAGE PACCHETTO BASIC



The package includes:

- Cordless impact wrench without battery (1/2": A.08.0009 3/4": A.08.0010)

Il pacchetto include:

- Avvitatore cordless senza batteria (1/2": A.08.0009 3/4": A.08.0010)

BEST FOR APPLICAZIONI



Cars, van, suv tyreshops
Gommisti vetture, van, suv



Industrial assembly
Montaggi industriali



AVAILABLE DISPONIBILE

TYPHOON 3/4" - A.08.0007

MAX TORQUE COPPIA MASSIMA	1000 Nm 885 ft-lb
WEIGHT PESO	3,56 Kg 7.84 lbs

Led light on the working
point during use

*Luce a Led sul punto di
lavoro durante l'uso*

Lithium ion battery 20.0 V D.C.
Batteria agli ioni di litio 20.0 V D.C.

TYPHOON

ELECTRIC RANGE

1"



Product code	<i>Codice prodotto</i>	A.08.0016
Square drive	<i>Attacco quadro</i>	1"
Weight with battery	<i>Peso con batteria</i>	3,4 kg - 7.5 lbs
Length	<i>Lunghezza</i>	260 mm - 10.23 in
Width	<i>Larghezza</i>	84 mm - 3.3 in
Height	<i>Altezza</i>	278 mm - 10.94 in
Voltage	<i>Voltaggio</i>	20,0V d.c.
Max torque	<i>Coppia massima</i>	1600 Nm - 1180 ft-lbs
Free speed	<i>Velocità libera</i>	1650 rpm
Amperage	<i>Amperaggio</i>	5.0 Ah



INCLUDED IN THE BOX INCLUSI NELLA SCATOLA



The package contains: charger, 2 batteries, operating and maintenance manual, after-sales suggestions.

La confezione contiene: caricabatterie, 2 batterie, manuale d'uso e manutenzione, indicazioni post-vendita.

AVAILABLE PACKAGES PACCHETTI DISPONIBILI

FULL PACKAGE - A.08.0016-A.08.0032-A.08.0033

PACCHETTO COMPLETO - A.08.0016- A.08.0032-A.08.0033



The package includes:

- Cordless impact wrench
- 2 batteries - 5/6 Ah
- Hard case
- Battery charger

Il pacchetto include:

- Avvitatore cordless
- 2 batterie - 5/6 Ah
- Custodia rigida
- Caricabatterie

STANDARD PACKAGE PACCHETTO STANDARD



The package includes:

- Cordless impact wrench (A.08.0015)
- 1 battery
- Optional: 2nd battery

Il pacchetto include:

- Avvitatore cordless (A.08.0015)
- 1 batteria
- Opzionale: seconda batteria

Battery Models	Product Code
5.0Ah	B.50.0009
6.0Ah	B.50.0010

BASIC PACKAGE PACCHETTO BASIC



The package includes:

- Cordless impact wrench without battery (A.08.0015)

Il pacchetto include:

- Avvitatore cordless senza batteria (A.08.0015)

BEST FOR APPLICAZIONI



Industrial assembly
Montaggi industriali

Motorsport socket connection
Connessione bussola in stile Motorsport

Aeronautical aluminum
Alluminio aeronautico

New flanged shaft:
much more reliable!

Nuovo albero flangiato:
molto più affidabile!

Led light on the working point during use
Luce a Led sul punto di lavoro durante l'utilizzo

Ergonomic handle
Impugnatura ergonomica

Battery level indicator
Indicatore di livello batteria

Lithium ion battery 20.0 V D.C.
Batteria agli ioni di litio 20.0 V D.C.

Fast battery charger
Caricabatterie rapido



ELECTRIC RANGE T9 BATTERIES

New Paoli electric range with the innovative T9 lithium ion battery 18.0 V. D.C.

Many more advantages in terms of technology and lightness. The new batteries are suitable for the use of brushless motors.

Suggested to be used in garages, tyreshops and a wide range of industrial applications, they are supplied in a hard case with a spare battery and a charger.

Advantages:

- Freedom of movement
- Speed and power
- Comfort and ergonomics for the operator
- Ease of use

GAMMA ELETTRICA BATTERIE T9

Nuova gamma elettrica Paoli con l'innovativa batteria T9 agli ioni di litio da 18,0 V. D.C.

Molti più vantaggi in termini di tecnologia e leggerezza. Le nuove batterie sono indicate per l'utilizzo di motori brushless.

Consigliati per un utilizzo garage, per i gommisti e per molteplici applicazioni industriali, sono forniti in una custodia rigida con una batteria di ricambio e un caricatore.

Vantaggi:

- *Libertà di movimento*
- *Velocità e potenza*
- *Comfort ed ergonomia per l'operatore*
- *Facilità d'utilizzo*



**ELECTRIC RANGE T9 BATTERIES
GAMMA ELETTRICA CON BATTERIE T9**

TORNADO

ELECTRIC RANGE

1/2"



Product code	<i>Codice prodotto</i>	A.08.0037
Square drive	<i>Attacco quadro</i>	1/2"
Weight with battery	<i>Peso con batteria</i>	2.1 kg - 4.62 lbs
Length	<i>Lunghezza</i>	170 mm - 6.7 in
Width	<i>Larghezza</i>	78 mm - 3.07 in
Height	<i>Altezza</i>	257 mm - 10.11 in
Voltage	<i>Voltaggio</i>	18.0V d.c.
Max torque	<i>Coppia massima</i>	461 Nm - 340 ft-lbs
Free speed	<i>Velocità libera</i>	2450 rpm
Amperage	<i>Amperaggio</i>	5.0 Ah



INCLUDED IN THE BOX INCLUSI NELLA SCATOLA



The package contains: charger, 2 batteries, operating and maintenance manual, after-sales suggestions.

La confezione contiene: caricabatterie, 2 batterie, manuale d'uso e manutenzione, indicazioni post-vendita.

AVAILABLE PACKAGES PACCHETTI DISPONIBILI

FULL PACKAGE A.08.0037
PACCHETTO COMPLETO A.08.0037



The package includes:

- Cordless impact wrench
- 2 batteries
- Hard case
- Battery charger

Il pacchetto include:

- Avvitatore cordless
- 2 batterie
- Custodia rigida
- Caricabatterie

STANDARD PACKAGE PACCHETTO STANDARD



The package includes:

- Cordless impact wrench
A.08.0038
- 1 battery
- Optional: 2nd battery

Il pacchetto include:

- Avvitatore cordless
A.08.0038
- 1 batteria
- Opzionale: seconda batteria

Battery Models	Product Code
5.0Ah	B.50.0019
6.0Ah	B.50.0020

BASIC PACKAGE PACCHETTO BASIC



The package includes:

- Cordless impact wrench
without battery
A.08.0038

Il pacchetto include:

- Avvitatore cordless
senza batteria
A.08.0038

BEST FOR APPLICAZIONI



Industrial assembly
Montaggi industriali

Led light on the working
point during use

Luce a Led sul punto di
lavoro durante l'uso

Selector switch (3 position)
Selettore (3 posizioni)

Ergonomic handle
Impugnatura ergonomica

Lithium ion T9 battery, 18.0 V D.C.
Batteria T9 agli ioni di litio 18.0 V D.C.



Brushless motor
Motore brushless

TYPHOON BRUSHLESS

ELECTRIC RANGE

1/2" - 3/4"



Product code	<i>Codice prodotto</i>	A.08.0040
Square drive	<i>Attacco quadro</i>	1/2"
Weight with battery	<i>Peso con batteria</i>	3.79 kg (8.35 lbs)
Length	<i>Lunghezza</i>	231 mm (9.10")
Width	<i>Larghezza</i>	80 mm (3.14")
Height	<i>Altezza</i>	295 mm (11.61")
Voltage	<i>Voltaggio</i>	20.0V d.c.
Max torque	<i>Coppia massima</i>	1000 Nm - 738 ft-lbs
Free speed	<i>Velocità libera</i>	1650 rpm
Amperage	<i>Amperaggio</i>	5.0/6.0 Ah



INCLUDED IN THE BOX INCLUSI NELLA SCATOLA



The package contains: charger, 2 batteries, operating and maintenance manual, after-sales suggestions.

La confezione contiene: caricabatterie, 2 batterie, manuale d'uso e manutenzione, indicazioni post-vendita.

AVAILABLE PACKAGES PACCHETTI DISPONIBILI

FULL PACKAGE - A.08.0040 - A.08.0043
PACCHETTO COMPLETO - A.08.0040 - A.08.0043



The package includes:

- Cordless impact wrench
- 2 batteries - 5/6 Ah
- Hard case
- Battery charger

Il pacchetto include:

- Avvitatore cordless
- 2 batterie - 5/6 Ah
- Custodia rigida
- Caricabatterie

STANDARD PACKAGE PACCHETTO STANDARD



The package includes:

- Cordless impact wrench
A.08.0031
- 1 battery
- Optional: 2nd battery

Il pacchetto include:

- Avvitatore cordless
A.08.0031
- 1 batteria
- Opzionale: seconda batteria

Battery Models	Product Code
5.0Ah	B.50.0019
6.0Ah	B.50.0020

BASIC PACKAGE PACCHETTO BASIC



The package includes:

- Cordless impact wrench
without battery
A.08.0031

Il pacchetto include:

- Avvitatore cordless
senza batteria
A.08.0031

BEST FOR APPLICAZIONI



Cars, van, suv tyreshops
Gommisti vetture, van, suv



Industrial assembly
Montaggi industriali

NEW MODEL! NUOVO MODELLO!



AVAILABLE DISPONIBILE

Typhoon Brushless 3/4"
A.08.0058 (5 Ah)
A.08.0059 (6 Ah)

MAX TORQUE
COPPIA MASSIMA 1000 Nm
738 ft-lb

WEIGHT
PESO 3,80 Kg
8.40 lbs

Led light on the working
point during use

*Luce a Led sul punto di
lavoro durante l'uso*

Lithium ion battery 20.0 V D.C.
Batteria agli ioni di litio 20.0 V D.C.

TYPHOON BRUSHLESS RHM

ELECTRIC RANGE HEAVY DUTY

3/4" - 1"



Product code	<i>Codice prodotto</i>	A.08.0055
Square drive	<i>Attacco quadro</i>	1"
Weight with battery	<i>Peso con batteria</i>	3,8 kg - 8.4 lbs
Length	<i>Lunghezza</i>	260 mm - 10.23 in
Width	<i>Larghezza</i>	84 mm - 3.3 in
Height	<i>Altezza</i>	278 mm - 10.94 in
Voltage	<i>Voltaggio</i>	20.0V d.c.
Max torque	<i>Coppia massima</i>	1500 Nm - 1106.34 ft-lbs
Free speed	<i>Velocità libera</i>	1540 rpm
Amperage	<i>Amperaggio</i>	5.0 Ah/6.0Ah



INCLUDED IN THE BOX INCLUSI NELLA SCATOLA



The package contains: charger, 2 batteries, operating and maintenance manual, after-sales suggestions.

La confezione contiene: caricabatterie, 2 batterie, manuale d'uso e manutenzione, indicazioni post-vendita.

AVAILABLE PACKAGES PACCHETTI DISPONIBILI

FULL PACKAGE - A.08.0055 - A.08.0056
PACCHETTO COMPLETO A.08.0055 - A.08.0056



The package includes:

- Cordless impact wrench
- 2 batteries
- Hard case
- Battery charger

Il pacchetto include:

- Avvitatore cordless
- 2 batterie
- Custodia rigida
- Caricabatterie

STANDARD PACKAGE PACCHETTO STANDARD



The package includes:

- Cordless impact wrench
A.08.0041
- 1 battery
- Optional: 2nd battery

Il pacchetto include:

- Avvitatore cordless
A.08.0041
- 1 batteria
- Opzionale: seconda batteria

Battery Models	Product Code
5.0Ah	B.50.0019
6.0Ah	B.50.0020

BASIC PACKAGE PACCHETTO BASIC



The package includes:

- Cordless impact wrench
without battery
A.08.0041

Il pacchetto include:

- Avvitatore cordless
senza batteria
A.08.0041

BEST FOR APPLICAZIONI



Industrial assembly
Montaggi industriali

NEW MODEL! NUOVO MODELLO!



RADIAL HAMMER MECHANISM

RHM Radial Hammer Mechanism for intensive industrial use

Massa Battente RHM Radial Hammer Mechanism per uso intensivo Industriale

AVAILABLE DISPONIBILE

Typhoon Brushless RHM 3/4"
A.08.0053 (5 Ah)
A.08.0054 (6 Ah)

MAX TORQUE
COPPIA MASSIMA 1300 Nm
959 ft-lb

WEIGHT
PESO 3,86 Kg
8,50 lbs

Heavy-Duty Impact
Mechanism for long durability
Massa Battente Heavy-Duty
per una lunga durabilità

Lithium ion T9 battery 20.0 V D.C.
Batteria T9 agli ioni di litio 20.0 V D.C.



MIX AND MATCH CREA LA TUA COMBINAZIONE

STANDARD PACKAGE PACCHETTO STANDARD

THE PACKAGE INCLUDES:

- Cordless impact wrench
- 1 battery
- Optional: 2nd battery

IL PACCHETTO INCLUDE:

- Avvitatore cordless
- 1 batteria
- Opzionale: seconda batteria



T7 BATTERIES BATTERIE T7



T9 BATTERIES BATTERIE T9

**CONFIGURE YOUR
STANDARD PACKAGE
CONFIGURA IL TUO
PACCHETTO STANDARD**

1 Choose your cordless impact wrench (without battery)
Scegli il tuo avvitatore cordless (senza batteria)

	Model Modello	Product Code Codice Prodotto
T7 batteries <i>Batterie T7</i>	Toolkit	A.08.0039
	Storm Brushless	A.08.0013
	Rocket	A.08.0011
	Typhoon 1/2"	A.08.0009
	Typhoon 3/4"	A.08.0010
	Typhoon 1"	A.08.0015
T9 batteries <i>Batterie T9</i>	Tornado	A.08.0038
	Typhoon Brushless 1/2"	A.08.0031
	Typhoon Brushless 3/4"	A.08.0057
	Typhoon Brushless RHM 3/4"	A.08.0042
	Typhoon Brushless RHM 1"	A.08.0041

2 Choose your battery pack
Scegli il tuo pacco batterie

	Model Modello	Product Code Codice Prodotto
T7 batteries <i>Batterie T7</i>	2.0Ah	B.50.0016
	5.0Ah	B.50.0009
	6.0Ah	B.50.0010
T9 batteries <i>Batterie T9</i>	5.0Ah	B.50.0019
	6.0Ah	B.50.0020

MIX AND MATCH CREA LA TUA COMBINAZIONE

TOOLKIT

PRODUCT CODE
CODICE PRODOTTO
A.08.0039

ROCKET

PRODUCT CODE
CODICE PRODOTTO
A.08.0011

TYPHOON 1"

PRODUCT CODE
CODICE PRODOTTO
A.08.0015

TYPHOON BRUSHLESS

PRODUCT CODE - 1/2"
CODICE PRODOTTO - 1/2"
A.08.0031

PRODUCT CODE - 3/4"
CODICE PRODOTTO - 3/4"
A.08.0057

STORM BRUSHLESS

PRODUCT CODE
CODICE PRODOTTO
A.08.0013

TYPHOON

PRODUCT CODE - 1/2"
CODICE PRODOTTO - 1/2"
A.08.0009

PRODUCT CODE - 3/4"
CODICE PRODOTTO - 3/4"
A.08.0010

TORNADO

PRODUCT CODE
CODICE PRODOTTO
A.08.0038

TYPHOON BRUSHLESS RHM 1"

PRODUCT CODE - 1"
CODICE PRODOTTO - 1"
A.08.0041

PRODUCT CODE - 3/4"
CODICE PRODOTTO - 3/4"
A.08.0042

BASIC PACKAGE PACCHETTO BASIC

THE PACKAGE INCLUDES:

- Cordless impact wrench without battery

IL PACCHETTO INCLUDE:

- Avvitatore cordless senza batteria



MIX AND MATCH CREA LA TUA COMBINAZIONE

BATTERIES AND BATTERY CHARGER BATTERIE E CARICABATTERIA

BATTERY PACK PACCO BATTERIA

Lithium ion battery
pack 20.0 V D.C.

- Options available:
5.0Ah - 6.0Ah
- Remaining capacity Led
indicator

*Pacco batteria agli ioni
di litio 20.0 V D.C.*

- *Opzioni disponibili:
5.0Ah - 6.0Ah*
- *Indicatore Led di carica
rimanente*



Battery Models <i>Modello batteria</i>		Product Code <i>Codice prodotto</i>
T7	5.0Ah	B.50.0009
	6.0Ah	B.50.0010
T9	5.0Ah	B.50.0019
	6.0Ah	B.50.0020



CHARGING TIME TEMPO DI CARICA

Battery Pack <i>Pacco batteria</i>	Battery charger <i>Caricabatterie</i>	
	B.50.0002	B.50.0011
5.0Ah	120 min	80 min
6.0Ah	140 min	100 min

BATTERY CHARGER CARICABATTERIE

Battery charger for Paoli cordless
impact wrenches.

- Led light indicators
- Battery diagnosis indicator
- Cable (available versions:
EU, UK, US)

*Caricabatteria per avvitatori cordless
Paoli*

- *Indicatori a luce Led*
- *Indicatore diagnostico batteria*
- *Cavo (versioni disponibili:
EU, UK, US)*



Product code <i>Codice prodotto</i>
T7 5.0Ah - 6.0Ah B.50.0011
T9 5.0Ah - 6.0Ah B.50.0018



CHOOSE YOUR CABLE SCEGLI IL TUO CAVO

Cable version <i>Versione cavo</i>	Product code <i>Codice prodotto</i>
EU	B.50.0003
UK	B.50.0004
US	B.50.0005



CASE CUSTODIA

Hard case for Paoli cordless impact wrenches.

Designed to hold:

- Impact wrench
- Batteries
- Battery charger

Custodia rigida per avvitatori cordless Paoli

Progettata per contenere:

- Avvitatore
- Batterie
- Caricabatterie



Product name <i>Nome prodotto</i>	Product Code <i>Codice prodotto</i>
Storm and Rocket case <i>Custodia Storm e Rocket</i>	T.03.11.0015
Typhoon case <i>Custodia Typhoon</i>	T.03.11.0014

CASE AND SOCKETS CUSTODIA E BUSSOLE

SOCKETS BUSSOLE

Super thin wall impact sockets

- Colour codes
- Square drive: 1/2"
- Designed for alloy wheels
- Ultra long life

Chiavi a bussola a parete ultrasottile

- Codici colore
- Attacco quadro: 1/2"
- Disegnate per i cerchi in lega
- Extra durata



PRODUCT CODE
CODICE PRODOTTO
L02.EKITL.001



⊙ Colors
Colore

17 mm
*Blu
Blu*

19 mm
*Gold
Oro*

21 mm
*Red
Rosso*



TORQUE CONTROL RANGE

The world of mechanics has been shifting towards increasingly sophisticated fitting processes and assembly methods with greater attention to specifications. Paoli has developed the new professional torque controlled tightening systems, to meet these requirements while facilitating the work and increasing the safety of operators. The Nutrunners are professional torque controlled wrenches designed for maximum efficiency and precision in the tightening process.

Paoli controlled torque screwdrivers combines enhanced speed of the (non-impact) volumetric air motor with an effective epicyclical reduction system achieving extremely high screwing values with 5% torque precision. An additional and fundamental feature derived from the torque arm design is the absence of a blowback mechanism, which drastically reduces noise and vibration.

GAMMA A COPPIA CONTROLLATA

Il mondo della meccanica si sta da tempo spostando verso processi di montaggio e tecniche di assemblaggio sempre più sofisticate e attente ai dettagli. Per rispondere a queste esigenze e nel contempo facilitare il lavoro e aumentare la sicurezza per gli operatori, Paoli ha sviluppato i nuovi sistemi professionali di avvitamento a coppia controllata, concepiti per ottenere la massima efficienza e precisione nei processi di avvitamento.

Gli avvitatori a coppia controllata Paoli uniscono le caratteristiche di velocità del motore pneumatico volumetrico (non ad impatto) alla potenza del gruppo di riduzione epicicloidale permettendo di raggiungere valori di serraggio elevatissimi con una precisione sulla coppia fornita del 5%. L'ulteriore e fondamentale caratteristica che deriva dal concetto di braccio di reazione è l'assenza del meccanismo di massa battente, con la conseguente drastica riduzione della rumorosità e delle vibrazioni.



**TORQUE CONTROL RANGE
GAMMA A COPPIA CONTROLLATA**

NUTRUNNERS

AVVITATORI A BRACCIO DI REAZIONE PNEUMATICI 3/4" - 1" - 1½"



Product name <i>Nome prodotto</i>	DP05-34	DP10-34	DP20-10	DP30-10	DP36-10	DP48-15
Product code <i>Codice prodotto</i>	A.06.0009	A.06.0010	A.06.0011	A.06.0012	A.06.0013	A.06.0015
Square drive <i>Attacco quadro</i>	3/4"	3/4"	1"	1"	1"	1 ½"
Bolt range <i>Capacità bullone</i>	M20	M24	M33	M36	M39	M52
Torque range <i>Campo di coppia</i>	125-500 Nm 90-370 ft-lb	250-1000 Nm 190-740 ft-lb	380-2000 Nm 300-1480 ft-lb	580-3000 Nm 450-2220 ft-lb	760-3600 Nm 600-2660 ft-lb	500-4800 Nm 370-3540 ft-lb
Max pressure <i>Pressione max</i>	6 bar 87 psi	6 bar 87 psi	6 bar 87 psi	6 bar 87 psi	6 bar 87 psi	6 bar 87 psi
Speed <i>Velocità</i>	55 rpm	27,5 rpm	7,2 rpm	4,2 rpm	3,6 rpm	12,9 rpm
Weight <i>Peso</i>	4,7 kg 10.4 lbs	4,9 kg 10.8 lbs	6,0 kg 13.2 lbs	6,6 kg 14.5 lbs	6,6 kg 14.5 lbs	8,5 kg 18.7 lbs
Air inlet <i>Ingresso aria</i>	1/4" BSP	1/4" BSP	1/4" BSP	1/4" BSP	1/4" BSP	1/4" BSP
Inner hose diameter <i>Diametro interno tubo</i>	8 mm 0.315 in	8 mm 0.315 in	8 mm 0.315 in	8 mm 0.315 in	8 mm 0.315 in	8 mm 0.315 in
Length <i>Lunghezza</i>	281 mm 11.06 in	297 mm 11.69 in	321 mm 12.64 in	337 mm 13.27 in	337 mm 13.27 in	437 mm 17.2 in

REACTION ARM BRACCIO DI REAZIONE

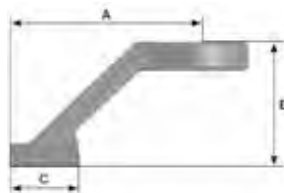

Available for <i>Disponibile per</i>	DP05-34	DP10-34	DP20-10	DP30-10	DP36-10
A	184 mm 7.24 in	184 mm 7.24 in	190 mm 7.48 in	230 mm 9.06 in	230 mm 9.06 in
B	100 mm 3.94 in	100 mm 3.94 in	100 mm 3.94 in	110 mm 4.33 in	110 mm 4.33 in
C	90 mm 3.54 in	90 mm 3.54 in	90 mm 3.54 in	90 mm 3.54 in	90 mm 3.54 in
Weight <i>Peso</i>	1.5 kg 3.30 lb	1.5 kg 3.30 lb	1.85 kg 4.08 lb	2.4 kg 5.29 lb	2.5 kg 5.51 lb

MAIN FEATURES CARATTERISTICHE PRINCIPALI

ANVIL TYPE TIPO ALBERO



With hole, without ring
Con foro, senza anello

AIR EXHAUST DIRECTION DIREZIONE SCARICO ARIA



Through the handle
Impugnatura

BEST FOR APPLICAZIONI



Industrial assembly
Montaggi industriali



Heavy vehicles
Mezzi pesanti



AVAILABLE DISPONIBILE

Chained ring available on demand
Anello calettato disponibili su richiesta

Controlled torque tightening
Serraggio a coppia controllata

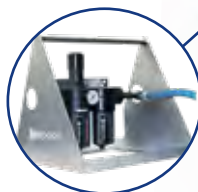

Air treatment for nutrunners
available (pag. 139)
*Gruppo trattamento aria
disponibile (pag. 139)*

Torque calibration table included
Tabella di calibrazione di coppia inclusa

Light weight
Leggero

Minimum vibration level
Vibrazioni minime

Heavy duty handle available for
industrial applications
*Disponibile impugnatura heavy
duty per applicazioni industriali*

Standard reaction arm included
Braccio di reazione standard incluso

Tools for arm mounting and fixing are included
Strumenti per montaggio e fissaggio braccio inclusi

Other reaction arms available on request
Altri bracci di reazione disponibili su richiesta

BATTERY NUTRUNNERS

AVVITATORI A BRACCIO DI REAZIONE A BATTERIA 3/4" - 1" - 1½"



Product name Nome prodotto	DP05-34B	DP10-34B	DP20-10B	DP30-10B	DP36-10B	DP48-15B	DP80-15B
Product code Codice prodotto	A.08.0017	A.08.0018	A.08.0019	A.08.0020	A.08.0021	A.08.0028	A.08.0029
Square drive Attacco quadro	3/4"	3/4"	1"	1"	1"	1½"	1½"
Bolt range Capacità bullone	M24-95	M27-95	M27-95	M36-95	M36-95	M52-95	M72-300
Torque range Campo di coppia	130-550 Nm 95-370 ft-lb	180-1000 Nm 130-740 ft-lb	220-2000 Nm 160-1480 ft-lb	330-3000 Nm 240-2220 ft-lb	380-3600 Nm 280-2660 ft-lb	500-4800 Nm 368- 3540 ft-lb	900-8000 Nm 664-5900 ft-lb
Speed Velocità	71,6 rpm	48,0 rpm	24,6 rpm	20,9 rpm	15,3 rpm	12,9 rpm	5,7 rpm
Voltage Voltaggio	18.0V d.c.	18.0V d.c.	18.0V d.c.	18.0V d.c.	18.0V d.c.	18.0V d.c.	18.0V d.c.
Weight Peso	5,35 kg 11.7 lbs	5,35 kg 11.7 lbs	6,85 kg 15.1 lbs	6,85 kg 15.1 lbs	6,85 kg 15.1 lbs	8,50 kg 18.7 lbs	13,50 kg 29.7 lbs
Height Altezza	245 mm 9.65 in	245 mm 9.65 in	245 mm 9.65 in	245 mm 9.65 in	245 mm 9.65 in	245 mm 9.65 in	245 mm 9.65 in
Length Lunghezza	365 mm 14.37 in	365 mm 14.37 in	405 mm 15.95 in	405 mm 15.95 in	405 mm 15.95 in	437 mm 17.20 in	522 mm 20.55 in

REACTION ARM BRACCIO DI REAZIONE

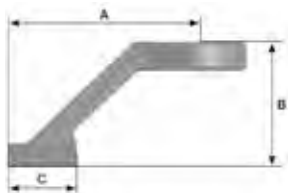

Available for Disponibile per	DP05-34B	DP10-34B	DP20-10B	DP30-10B	DP36-10B	DP48-15B	DP80-15B
A	150 mm 5.9 in	150 mm 5.9 in	150 mm 5.9 in	190 mm 7.48 in	190 mm 7.48 in	210 mm 8.26 in	250 mm 9.84 in
B	80 mm 3.15 in	80 mm 3.15 in	100 mm 3.94 in	100 mm 3.94 in	100 mm 3.94 in	130 mm 5.11 in	165 mm 6.49 in
C	90 mm 3.54 in	90 mm 3.54 in	90 mm 3.54 in	90 mm 3.54 in	90 mm 3.54 in	90 mm 3.54 in	140 mm 5.51 in
Weight Peso	1.5 kg 3.30 lb	1.5 kg 3.30 lb	1.85 kg 4.08 lb	2.14 kg 4.71 lb	2.14 kg 4.71 lb	2.14 kg 4.71 lb	5.30 kg 11.68 lb

MAIN FEATURES CARATTERISTICHE PRINCIPALI



Cordless
A batteria



Provided in a hard case
Custodia rigida compresa



BEST FOR APPLICAZIONI



Industrial assembly
Montaggi industriali



Heavy vehicles
Mezzi pesanti

High performance gearbox with
a slim design
*Trasmissione ad alte prestazioni
con un design compatto*

Automatic locking
Bloccaggio automatico

Gear selector, single steps
Selettore cambio, passi singoli

Brushless motor
Motore brushless

Ergonomic handle
Impugnatura ergonomica

Battery level indicator
Indicatore di livello batteria

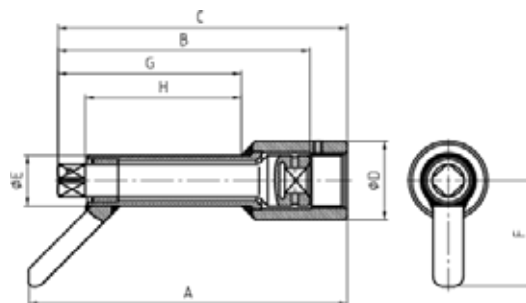

WHEEL EXTENSION MEASUREMENTS
PROLUNGHE DI COPPIA

Product Name <i>Nome prodotto</i>	Drive size <i>Attacco</i>	A	B	C	ØD	ØE	F	G	H
DPEXT-07	3/4" - 19 mm	9.38 in - 238 mm	6.90 in - 175 mm	8.27 in - 210 mm	2.76 in - 70 mm	1.89 in - 48 mm	3.94 in - 100 mm	4.57 in - 116 mm	3.62 in - 92 mm
DPEXT-07-8	3/4" - 19 mm	10.36 in - 263 mm	7.88 in - 200 mm	9.26 in - 235 mm	2.76 in - 70 mm	1.89 in - 48 mm	3.94 in - 100 mm	5.43 in - 138 mm	4.49 in - 114 mm
DPEXT-07-10	3/4" - 19 mm	12.33 in - 313 mm	9.85 in - 250 mm	11.23 in - 285 mm	2.76 in - 70 mm	1.89 in - 48 mm	3.94 in - 100 mm	7.56 in - 192 mm	6.61 in - 168 mm
DPEXT-07-13	3/4" - 19 mm	15.48 in - 393 mm	13.0 in - 330 mm	14.83 in - 365 mm	2.76 in - 70 mm	1.89 in - 48 mm	3.94 in - 100 mm	10.55 in - 268 mm	9.61 in - 244 mm
DPEXT-10	1" - 25 mm	9.50 in - 241 mm	6.90 in - 175 mm	8.35 in - 212 mm	3.07 in - 78 mm	2.05 in - 52 mm	4.33 in - 110 mm	4.37 in - 111 mm	3.23 in - 82 mm
DPEXT-10-8	1" - 25 mm	10.48 in - 266 mm	7.88 in - 200 mm	13.28 in - 237 mm	3.07 in - 78 mm	2.05 in - 52 mm	4.33 in - 110 mm	5.24 in - 133 mm	4.09 in - 104 mm
DPEXT-10-10	1" - 25 mm	12.45 in - 316 mm	9.85 in - 250 mm	11.31 in - 287 mm	3.07 in - 78 mm	2.05 in - 52 mm	4.33 in - 110 mm	7.36 in - 187 mm	6.22 in - 158 mm
DPEXT-10-13	1" - 25 mm	15.60 in - 396 mm	13.0 in - 330 mm	14.46 in - 367 mm	3.07 in - 78 mm	2.05 in - 52 mm	4.33 in - 110 mm	10.35 in - 263 mm	9.21 in - 234 mm
DPEXT-25	1" - 25 mm	10.05 in - 255 mm	6.90 in - 175 mm	8.51 in - 216 mm	3.55 in - 90 mm	2.36 in - 60 mm	5.32 in - 135 mm	4.06 in - 103 mm	2.99 in - 76 mm
DPEXT-25-8	1" - 25 mm	11.03 in - 280 mm	7.88 in - 200 mm	9.50 in - 241 mm	3.55 in - 90 mm	2.36 in - 60 mm	5.32 in - 135 mm	5.04 in - 128 mm	3.98 in - 101 mm
DPEXT-25-10	1" - 25 mm	13.0 in - 330 mm	9.85 in - 250 mm	11.47 in - 291 mm	3.55 in - 90 mm	2.36 in - 60 mm	5.32 in - 135 mm	7.01 in - 178 mm	5.94 in - 151 mm
DPEXT-25-13	1" - 25 mm	16.15 in - 410 mm	13.0 in - 330 mm	14.62 in - 371 mm	3.55 in - 90 mm	2.36 in - 60 mm	5.32 in - 135 mm	10.16 in - 258 mm	9.09 in - 231 mm

REACTION ARM BRACCIO DI REAZIONE



*Weight, dimensions and max torque on demand
*Peso, dimensioni e coppia su richiesta



EXTENSION ESTENSIONE



MOBILE MEASURING UNIT UNITÀ DI MISURAZIONE MOBILE



The MMU measures the applied torque and the subsequent bolting process directly on site. The system works wirelessly during the bolting process and can easily be mounted to the torque tool.

Il MMU misura la coppia applicata e il successivo processo di bullonatura direttamente in loco. Il sistema funziona in modalità wireless durante il processo di bullonatura e può essere facilmente montato sullo strumento di coppia.

Product Name Nome prodotto	Reaction Arm <i>Braccio di reazione</i>	Extension <i>Estensione</i>
Max torque Coppia massima	4800 Nm 3540 ft-ls	4800 Nm 3540 ft-ls
Weight Peso	15,10 lbs 6,85 kg	8,96 kg 19,75 lbs
Dimensions Dimensioni	--	220 mm - 623 mm 8.6 in - 24.5 in

Product Name Nome prodotto	MMU-11	MMU-41	MMU-55
Range min-max	110-1100 Nm 81-811 ft-lbs	410-4100 Nm 302-3024 ft-lbs	550-5500 Nm 406-4056 ft-lbs
Compatible with <i>Compatibile con</i>	DP05-34B DP10-34B	DP20-10B DP30-10B DP36-10B	DP48-15B

ELECTRIC SCREWDRIVERS

CACCIAVITI ELETTRICI

KBL SERIES SERIE KBL



CONTROL UNIT UNITÀ DI CONTROLLO

The screwdriving system is composed by a screwdriver, a cable with connectors and a power supply and control unit.

Control unit features:

120W, 5 pin connector, adjustable speed

Il complesso di avvitatura è formato dall'avvitatore, dal cavo con connettore e dall'unità di controllo ed alimentazione.

Caratteristiche dell'unità di controllo:

120W, 1 connettore 5 pin, velocità regolabile.

Product Name Nome prodotto	Product code Codice prodotto	Weight Peso	Dimensions Dimensioni
EDU1BL	A.10.0005	0,6 kg	130 x 118 x 67 mm



SCREWDRIVER AVVITATORE

Product Name Nome prodotto	KBL04FR	KBL15FR	KBL30FR	KBL40FR
Product code Codice prodotto	A.10.0001	A.10.0002	A.10.0003	A.10.0004
Torque Coppia (Nm)	0,04-0,4	0,4-1,5	0,7-3,0	0,9-4,0
RPM (min-max)	650-1000	650-1000	650-1000	450-750
Output	Hex 1/4"	Hex 1/4"	Hex 1/4"	Hex 1/4"
Weight Peso	0,50 kg	0,50 kg	0,65 kg	0,65 kg
Dimensions Dimensioni	255 x 37 mm	255 x 37 mm	268 x 43 mm	268 x 43 mm

PLUTO SERIES SERIE PLUTO



CONTROL UNIT UNITÀ DI CONTROLLO

The screwdriving system is composed by a screwdriver, a cable with connectors and a power supply and control unit.

Control unit features:

programmable with user interface screen, integrated screw counter, serial print, optional screwdriver connection on back panel.

Il complesso di avvitatura è formato dall'avvitatore, dal cavo con connettore e dall'unità di controllo ed alimentazione.

Caratteristiche dell'unità di controllo:

parametri programmabili da display, conteggio viti, stampa seriale, connettore per avvitatore in alternativa su pannello posteriore.

Product Name Nome prodotto	Product code Codice prodotto	Weight Peso	Dimensions Dimensioni
EDU2AE/HPro	A.10.0010	2,4 kg	195 x 170 x 110 mm



SCREWDRIVER AVVITATORE

Product Name Nome prodotto	Pluto 3D	Pluto 6D	Pluto 10D/N	Pluto 15D/N
Product code Codice prodotto	A.10.0006	A.10.0007	A.10.0008	A.10.0009
Torque Coppia (Nm)	0,5-3,0	0,85-6,0	1,5-10,0	2,0-15,0
RPM (min-max)	370-1300	200-850	110-600	60-320
Output	Hex 1/4"	Hex 1/4"	Hex 1/4"	Hex 1/4"
Weight Peso	0,55 kg	0,55 kg	0,55 kg	0,60 kg
Dimensions Dimensioni	226 x 40 mm	226 x 40 mm	226 x 40 mm	226 x 40 mm

TORQUE WRENCHES

CHIAVI DINAMOMETRICHE

FEATURES

- Torque accuracy: $\pm 2\%$
- Torque/Angle accuracy: $\pm 2\%$
- Peak hold and track mode direct readings.
- Tolerance range adjustment both on torque and angle.
- User tightening sets definition.
- Optical signals through 3 leds, and acoustical signal with buzzer.
- Clockwise and anticlockwise (CW and CCW) readings.
- Memory up to 900 values.
- Angle and Torque Preset.
- Auto switch-off.
- N-m, Kgf m, Lbf in, Lbf ft.

CARATTERISTICHE

- *Precisione della coppia: $\pm 2\%$*
- *Precisione coppia/angolo: $\pm 2\%$*
- *Peak hold e track mode letture dirette.*
- *Regolazione dell'intervallo di tolleranza sia sulla coppia che sull'angolo.*
- *Il serraggio utente definisce la definizione.*
- *Segnali ottici tramite 3 led e segnale acustico con buzzer.*
- *Letture in senso orario e antiorario (CW e CCW).*
- *Memoria fino a 900 valori.*
- *Impostazione Angolo e Coppia.*
- *Spegnimento automatico.*
- *N-m, Kgf m, Lbf in, Lbf ft.*

DIGITAL TORQUE WRENCHES CHIAVI DINAMOMETRICHE DIGITALI



Product Name <i>Nome prodotto</i>	23000-DGT	2600-DGT	2400-DGT
Product code <i>Codice prodotto</i>	B.35.0002	B.35.0003	B.35.0004
Capacity (Nm) <i>Capacità (Nm)</i>	100-1000 Nm	80-800 Nm	20-200 Nm
Drive <i>Attacco</i>	1"	3/4"	1/2"
Length <i>Lunghezza</i>	52.7 in 1340 mm	43.3 in 1100 mm	20.1 in 512 mm
Weight <i>Peso</i>	14.5 lbs 6,60 kg	9.7 lbs 4,40 Kg	2.7 lbs 1,25 kg
Accessories <i>Accessori</i>	USB data transfer kit (Product code: B.35.0011 <i>Kit USB per trasferimento dati (Codice prodotto: B.35.0011)</i>)		

TORQUE WRENCHES WITH RATCHET CHIAVI DINAMOMETRICHE A CRICCHETTO



FEATURES

- Fast and easy setting.
- Long life accuracy and repeatability.
- Ergonomic handle.
- With graduated scale in N-m and Lbf.ft.
- Dual signal when the set torque is reached: acoustical click and effort decrease.
- Guaranteed accuracy $\pm 3\%$ in accordance with EN ISO 6789:2003.

CARATTERISTICHE

- Impostazione facile e veloce.
- Precisione e ripetibilità di lunga durata.
- Impugnatura ergonomica.
- Con scala graduata in N-m e Lbf.ft.
- Doppio segnale al raggiungimento della coppia impostata: scatto acustico e diminuzione dello sforzo.
- Precisione garantita $\pm 3\%$ secondo EN ISO 6789:2003.

Product Name Nome prodotto	300	330	350
Product code Codice prodotto	B.35.0008	B.35.0009	B.35.0010
Capacity (Nm) Capacità (Nm)	40-200 Nm 30-150 lbf.ft	160-800 Nm 120-590 lbf.ft	200-1000 Nm 150-750 lbf.ft
<input type="checkbox"/>	1/2"	3/4"	3/4"
Length Lunghezza	450 mm	1180 mm	1340 mm
Weight Peso	1,20 kg	6,70 kg	7,40 kg

DIAL TORQUE WRENCHES CHIAVI DINAMOMETRICHE ANALOGICHE



FEATURES

- Left and right hand use.
- Precise tightening achieved by the torsion bar system.
- The small head allows torque application even in narrow areas.
- Reading scale in Nm/Lbf.in or Nm/Lbf.ft.
- Accuracy $\pm 4\%$.
- Traceable calibration certificate through accredited laboratories.

CARATTERISTICHE

- Uso con mano destra e sinistra.
- Serraggio preciso ottenuto con il sistema a barra di torsione.
- La testa piccola permette l'applicazione della coppia anche in aree strette.
- Scala di lettura in Nm/Lbf.in o Nm/Lbf.ft.
- Precisione 4%.
- Certificato di taratura tracciabile tramite laboratori accreditati.

Product Name Nome prodotto	7000	800	700
Product code Codice prodotto	B.35.0005	B.35.0006	B.35.0007
Capacity (Nm) Capacità (Nm)	300-1500	80-400	40-200
STEP	20 Nm	5 Nm	2,5 Nm
<input type="checkbox"/>	1"	1/2"	1/2"
Length Lunghezza	1956 mm (including extension)	559 mm	559 mm
Weight Peso	9,072 kg	1,361 kg	1,361 kg

ATEX IMPACT WRENCHES

Paoli Atex impact wrenches have passed rigorous tests made in highly explosive environments and deposited at notified body IMQ in order to offer to the users a safe, innovative and efficient product.

The Atex range is composed by models suitable for underground environments  IM2 Ex h I Mb X
II 2G Ex h IIB T6 Gb X
II 2D Ex h IIB T85°C and by impact wrenches designed for surface applications  II 2G Ex h IIB T6 Gb X
II 2D Ex h IIB T85°C.

All this drives us to a impact wrenches range able to satisfy our clients' needs.

PAOLI has updated the ATEX certifications according to the latest ISO regulations, in compliance with the 2014/34/EU and 2006/42/EC Directives, adding new standards to its declarations of conformity:

UNI EN 1127-1:2019, UNI CEI EN ISO 80079-36:2016, UNI CEI EN ISO 80079-37:2016, UNI EN ISO 11148-6:2013, UNI EN 1127-2:2014 and UNI CEI EN ISO 80079 -38:2016.

The updated ATEX markings and strings are in accordance with the IEC/EN 60079-0 standard.

With the latest filing of the updated technical files at IMQ, PAOLI products are confirmed to be among the safest and most up-to-date on the market according to current regulations.

AVVITATORI ATEX

Gli avvitatori Atex Paoli hanno superato rigorosi test effettuati in situazioni ed atmosfere altamente esplosive e depositati presso l'organismo notificato IMQ per poter offrire agli utenti finali un prodotto estremamente sicuro, innovativo e performante.

La gamma Atex si compone di modelli adatti all'utilizzo in ambienti sottosuolo/miniera  IM2 Ex h I Mb X
II 2G Ex h IIB T6 Gb X
II 2D Ex h IIB T85°C *e di avvitatori progettati per*

l'impiego in zone generalmente di superficie  II 2G Ex h IIB T6 Gb X
II 2D Ex h IIB T85°C *. Tutto questo si traduce in una gamma di avvitatori in grado di soddisfare ogni esigenza dei nostri clienti.*

PAOLI ha aggiornato le certificazioni ATEX secondo le ultime normative ISO, in ottemperanza alle Direttive 2014/34/UE e 2006/42/CE, aggiungendo nuovi standards alle proprie dichiarazioni di conformità:

UNI EN 1127-1:2019, UNI CEI EN ISO 80079-36:2016, UNI CEI EN ISO 80079-37:2016, UNI EN ISO 11148-6:2013, UNI EN 1127-2:2014 e UNI CEI EN ISO 80079-38:2016.

Le aggiornate marcature e stringhe ATEX sono in accordo con la normativa IEC/EN 60079-0.

Con l'ultimo deposito degli aggiornati fascicoli tecnici presso IMQ, I prodotti PAOLI si confermano tra i più sicuri e aggiornati del mercato secondo le normative vigenti.



paoli
ATEX RANGE
MADE IN ITALY
EXTREME
I M2 Ex h I Mb X
II 2G Ex h IIB T6 Gb X
II 2D Ex h IIB T85°C Db X

ATEX IMPACT WRENCHES
AVVITATORI A NORMA ATEX

ATEX IMPACT WRENCHES NORMATIVE

II 2G Ex h IIB T6 Gb X

II [Equipment group II] - Which corresponds to equipment intended for work in surface systems.

2 [Category 2] - Includes equipment designed to operate in accordance with the operating parameters established by the manufacturer and to ensure a high level of protection.

G - The letter "G" refers to explosive atmospheres due to the presence of gases, vapours or mists.

Ex h - Protection method for constructional safety, non-electrical protection

IIB - Group of permitted gases (excluding IIC e.g. acetylene, hydrogen etc.).

T6 - Max surface temperature for gas (85°C)

Gb - EPL for gas

X - Special condition of applicability

I M2 Ex h I Mb X

I [Equipment group I] - corresponds to equipment intended for underground work in mines.

M2 [Category M2] - equipment or protective systems ensuring a high level of protection; they must be able to be switched off in the presence of the gas

Ex h - Protection method for constructional safety, non-electrical protection.

I [Equipment group I] - corresponds to equipment intended for underground work in mines.

Mb - EPL for mine environments

X - Special condition of applicability

II 2G Ex h IIB T6 Gb X

II [Gruppo di apparecchi II] - Che corrisponde ad apparecchi destinati ai lavori negli impianti di superficie.

2 [Categoria 2] - Comprende gli apparecchi progettati per funzionare conformemente ai parametri operativi stabiliti dal fabbricante e garantire un livello di protezione elevato.

G - La lettera "G" è relativa alle atmosfere esplosive dovute alla presenza di gas, di vapori o di nebbie.

Ex h - Metodo di protezione per sicurezza costruttiva, protezione non elettrica

IIB - Gruppo di gas ammessi (escluso IIC p.es. acetilene, idrogeno ecc.).

T6 - Temperatura max superficiale per gas (85°C)

Gb - EPL per gas

X - Condizioni speciali di applicabilità

I M2 Ex h I Mb X

I [Gruppo di apparecchi I] - corrisponde ad apparecchi destinati ai lavori in sotterraneo nelle miniere.

M2 [Categoria M2] - apparecchi o sistemi di protezione che garantiscono un livello di protezione elevato; devono potere essere messi fuori tensione in presenza del gas

Ex h - Metodo di protezione per sicurezza costruttiva, protezione non elettrica.

I [Gruppo di apparecchi I] - corrisponde ad apparecchi destinati ai lavori in sotterraneo nelle miniere.

Mb - EPL per ambienti miniera

X - Condizioni speciali di applicabilità

RED DEVIL SL ATEX

ATEX SERIES

1/2"



Product code	<i>Codice prodotto</i>	A.07.01.0001
Square drive	<i>Attacco quadro</i>	1/2"
Bolt range	<i>Capacità bullone</i>	M10-M24
Max torque	<i>Coppia massima</i>	800 Nm - 590 ft-lb
Working torque	<i>Coppia raccomandata</i>	80-600 Nm - 60-450 ft-lb
Weight	<i>Peso</i>	2,40 kg - 5.30 lbs
Free speed	<i>Velocità libera</i>	12000 rpm
Impacts number	<i>Numero impatti</i>	2000/min
Working pressure	<i>Pressione di utilizzo</i>	6,5 bar - 94 psi
Air inlet	<i>Ingresso aria</i>	1/4" NPT
Inner hose diameter	<i>Diametro interno tubo</i>	13 mm - 0.512 in
Length	<i>Lunghezza</i>	192,6 mm - 7.58 in
Side to center	<i>Ingombro centro lato</i>	40 mm - 1.57 in
Vibration level - triaxial	<i>Livello vibrazioni - triassiale</i>	9,1 m/s ²
Sound pressure level	<i>Pressione sonora</i>	97 dB(A)



INCLUDED IN THE BOX **INCLUSI NELLA SCATOLA**



The package contains: oil for impact wrench motors, operating and maintenance manual, after-sales suggestions.

La confezione contiene: olio per i motori degli avvitatori, manuale d'uso e manutenzione, indicazioni post-vendita.

MAIN FEATURES CARATTERISTICHE PRINCIPALI

HAMMER MECHANISM TIPO MASSE BATTENTI



Twin hammer
Doppio martello

ANVIL TYPE TIPO ALBERO



With ring, without hole
Con anello, senza foro

AIR EXHAUST DIRECTION DIREZIONE SCARICO ARIA



Sides exhaust
Bilaterale

HAMMER MECHANISM LUBRICATION LUBRIFICAZIONE MASSE BATTENTI



Grease
Grasso

BEST FOR APPLICAZIONI



Mine and oil field
Miniere e giacimenti



Construction site and shipyard
Cantieri e costruzioni navali



Industrial assembly
Montaggi industriali



Offshore platforms
Piattaforme offshore



Twin hammer mechanism
Masse battenti a doppio martello

Certified paint
Vernice certificata



II 2G EX h IIB T6 Gb X
II 2D Ex h IIIB T85°C

Air inlet with phosphate manganese
coating treatment
*Ingresso aria trattato con rivestimento
fosfatazione al manganese*

DP 217 ATEX

ATEX SERIES

3/4"



Square drive	<i>Attacco quadro</i>	3/4"
Bolt range	<i>Capacità bullone</i>	M14-M24
Max torque	<i>Coppia massima</i>	1700 Nm - 1260 ft-lb
Working torque	<i>Coppia raccomandata</i>	350-910 Nm - 240-680 ft-lb
Free speed	<i>Velocità libera</i>	5400 rpm
Impacts number	<i>Numero impatti</i>	1000/min
Working pressure	<i>Pressione di utilizzo</i>	6,3 bar - 91 psi
Air inlet	<i>Ingresso aria</i>	1/2" BSP
Inner hose diameter	<i>Diametro interno tubo</i>	13 mm - 0.512 in
Length	<i>Lunghezza</i>	221 mm - 8.7 in
Side to center	<i>Ingombro centro lato</i>	48 mm - 1.9 in
Vibration level - triaxial	<i>Livello vibrazioni - triassiale</i>	9,4 m/s ²
Sound pressure level	<i>Pressione sonora</i>	104 dB(A)



INCLUDED IN THE BOX INCLUSI NELLA SCATOLA



The package contains: lifting eye bolt, handle (in compliance with the CE UNI EN ISO 11148-6 norm), oil for impact wrench motors, operating and maintenance manual, after-sales suggestions.

La confezione contiene: gomitolo, maniglia (in conformità con la normativa CE UNI EN ISO 11148-6), olio per i motori degli avvitatori, manuale d'uso e manutenzione, indicazioni post-vendita.

MAIN FEATURES CARATTERISTICHE PRINCIPALI

HAMMER MECHANISM TIPO MASSE BATTENTI



3-jaw
3 griffe

ANVIL TYPE TIPO ALBERO



With ring, with hole
Con anello, con foro

AIR EXHAUST DIRECTION DIREZIONE SCARICO ARIA



Through the handle
Impugnatura

HAMMER MECHANISM LUBRICATION LUBRIFICAZIONE MASSE BATTENTI



Grease
Grasso

BEST FOR APPLICAZIONI



Mine and oil field
Miniere e giacimenti



Construction site and shipyard
Cantieri e costruzioni navali



Industrial assembly
Montaggi industriali



Offshore platforms
Piattaforme offshore

Hammer mechanism: 3-jaw
Tipo masse battenti: 3 griffe

Certified paint
Vernice certificata





Air exhaust through the handle

- less noise
- no harmful dust

Scarico dell'aria esausta nell'impugnatura

- minore rumorosità
- assenza di polveri nocive

Air inlet with phosphate
manganese coating treatment
*Ingresso aria trattato con
rivestimento fosfatazione
al manganese*

AVAILABLE MODELS MODELLI DISPONIBILI	PRODUCT CODE CODICE PRODOTTO	WEIGHT PESO	OUTER MATERIAL MATERIALE ESTERNO
 I M2 Ex h I Mb X II 2G EX h IIB T6 Gb X II 2D Ex h IIIB T85°C	A.07.11.0002	7,5 kg 1.5 lbs	Zama
 II 2G EX h IIB T6 Gb X II 2D Ex h IIIB T85°C	A.07.11.0003	6,1 kg 13,4 lbs	Aluminium

DP 246 ATEX

ATEX SERIES

1"



Product code	<i>Codice prodotto</i>	A.07.51.0001
Square drive	<i>Attacco quadro</i>	1"
Bolt range	<i>Capacità bullone</i>	M18-M39
Max torque	<i>Coppia massima</i>	2800 Nm - 2070 ft-lb
Working torque	<i>Coppia raccomandata</i>	600-1400 Nm - 440-1020 ft-lb
Weight	<i>Peso</i>	8,24 kg - 18.2 lbs
Free speed	<i>Velocità libera</i>	4200 rpm
Impacts number	<i>Numero impatti</i>	750/min
Working pressure	<i>Pressione di utilizzo</i>	6,3 bar - 91 psi
Air inlet	<i>Ingresso aria</i>	1/2" BSP
Inner hose diameter	<i>Diametro interno tubo</i>	13 mm - 0.512 in
Length	<i>Lunghezza</i>	282 mm - 11.1 in
Side to center	<i>Ingombro centro lato</i>	50 mm - 1.97 in
Vibration level - triaxial	<i>Livello vibrazioni - triassiale</i>	4,079 m/s ²
Sound pressure level	<i>Pressione sonora</i>	94 dB(A)

INCLUDED IN THE BOX INCLUSI NELLA SCATOLA



The package contains: handle (in compliance with the CE UNI EN ISO 11148-6 norm), oil for pneumatic motors, operating and maintenance manual, after-sales suggestions.

La confezione contiene: maniglia (in conformità con la normativa CE UNI EN ISO 11148-6), olio per motori pneumatici, manuale d'uso e manutenzione, indicazioni post-vendita.

MAIN FEATURES CARATTERISTICHE PRINCIPALI

HAMMER MECHANISM TIPO MASSE BATTENTI



Pin-clutch
Pin-clutch

ANVIL TYPE TIPO ALBERO



With ring, with hole
Con anello, con foro

AIR EXHAUST DIRECTION DIREZIONE SCARICO ARIA



Through the handle
Impugnatura

HAMMER MECHANISM LUBRICATION LUBRIFICAZIONE MASSE BATTENTI



Oil
Olio

BEST FOR APPLICAZIONI



Mine and oil field
Miniere e giacimenti



Construction site and shipyard
Cantieri e costruzioni navali



Industrial assembly
Montaggi industriali



Offshore platforms
Piattaforme offshore

Certified paint
Vernice certificata

Pin-Clutch hammer mechanism with oil bath lubrication system
Long-lasting hammer mechanism life
Massa battente pin-clutch a bagno d'olio
Lunga vita alla massa battente

Air exhaust through the handle

- less noise
- no harmful dust

Scarico dell'aria esausta nell'impugnatura

- minore rumorosità
- assenza di polveri nocive

Air inlet with phosphate manganese coating treatment
Ingresso aria trattato con rivestimento fosfatazione al manganese



II 2G EX h IIB T6 Gb X
II 2D Ex h IIIB T85°C

DP 251 ATEX

ATEX SERIES

1"



Square drive	<i>Attacco quadro</i>	1"
Bolt range	<i>Capacità bullone</i>	M18-M39
Max torque	<i>Coppia massima</i>	3300 Nm - 2440 ft-lb
Working torque	<i>Coppia raccomandata</i>	700-1600 Nm - 510-1160 ft-lb
Free speed	<i>Velocità libera</i>	3100 rpm
Impacts number	<i>Numero impatti</i>	780/min
Working pressure	<i>Pressione di utilizzo</i>	6,3 bar - 91 psi
Air inlet	<i>Ingresso aria</i>	1/2" BSP
Inner hose diameter	<i>Diametro interno tubo</i>	13 mm - 0.512 in
Length	<i>Lunghezza</i>	271 mm - 10.67 in
Side to center	<i>Ingombro centro lato</i>	57.5 mm - 2.26 in
Vibration level - triaxial	<i>Livello vibrazioni - triassiale</i>	4,8 m/s ²
Sound pressure level	<i>Pressione sonora</i>	100 dB(A)



INCLUDED IN THE BOX INCLUSI NELLA SCATOLA



The package contains: lifting eye bolt, handle (in compliance with the CE UNI EN ISO 11148-6 norm), oil for impact wrench motors, operating and maintenance manual, after-sales suggestions.

La confezione contiene: golfare, maniglia (in conformità con la normativa CE UNI EN ISO 11148-6), olio per i motori degli avvitatori, manuale d'uso e manutenzione, indicazioni post-vendita.

MAIN FEATURES CARATTERISTICHE PRINCIPALI

HAMMER MECHANISM TIPO MASSE BATTENTI



3-jaw
3 griffe

ANVIL TYPE TIPO ALBERO



With ring, with hole
Con anello, con foro

AIR EXHAUST DIRECTION DIREZIONE SCARICO ARIA



Through the handle
Impugnatura

HAMMER MECHANISM LUBRICATION LUBRIFICAZIONE MASSE BATTENTI



Grease
Grasso

BEST FOR APPLICAZIONI



Mine and oil field
Miniere e giacimenti



Construction site and shipyard
Cantieri e costruzioni navali



Industrial assembly
Montaggi industriali



Offshore platforms
Piattaforme offshore

Upgraded 3-jaw hammer mechanism
Masse battenti a 3 griffe perfezionate

Increased weight/power ratio
Rapporto peso/potenza aumentato

Air exhaust through the handle

- less noise
- no harmful dust

Scarico dell'aria esausta nell'impugnatura

- minore rumorosità
- assenza di polveri nocive

Certified paint
Vernice certificata

Air inlet with phosphate manganese coating treatment
Ingresso aria trattato con rivestimento fosfatazione al manganese

AVAILABLE MODELS MODELLI DISPONIBILI	PRODUCT CODE CODICE PRODOTTO	WEIGHT PESO	OUTER MATERIAL MATERIALE ESTERNO
 I M2 Ex h I Mb X II 2G EX h IIB T6 Gb X II 2D Ex h IIB T85°C	A.07.21.0002	12 kg 26.4 lbs	Zama
 II 2G EX h IIB T6 Gb X II 2D Ex h IIB T85°C	A.07.21.0003	9,1 kg 20 lbs	Aluminium

DP 256 BG ATEX

ATEX SERIES

1"



Square drive	<i>Attacco quadro</i>	1"
Bolt range	<i>Capacità bullone</i>	M18-M39
Max torque	<i>Coppia massima</i>	3200 Nm - 2360 ft-lb
Working torque	<i>Coppia raccomandata</i>	600-1700 Nm - 450-1240 ft-lb
Free speed	<i>Velocità libera</i>	3200 rpm
Impacts number	<i>Numero impatti</i>	750/min
Working pressure	<i>Pressione di utilizzo</i>	6,3 bar - 91 psi
Air inlet	<i>Ingresso aria</i>	1/2" BSP
Inner hose diameter	<i>Diametro interno tubo</i>	13 mm - 0.512 in
Length	<i>Lunghezza</i>	357 mm - 14.05 in
Side to center	<i>Ingombro centro lato</i>	56 mm - 2.20 in
Vibration level - triaxial	<i>Livello vibrazioni - triassiale</i>	4,9 m/s ²
Sound pressure level	<i>Pressione sonora</i>	101 dB(A)



INCLUDED IN THE BOX INCLUSI NELLA SCATOLA



The package contains: lifting eye bolt, handle (in compliance with the CE UNI EN ISO 11148-6 norm), oil for impact wrench motors, operating and maintenance manual, after-sales suggestions.

La confezione contiene: golfare, maniglia (in conformità con la normativa CE UNI EN ISO 11148-6), olio per i motori degli avvitatori, manuale d'uso e manutenzione, indicazioni post-vendita.

MAIN FEATURES CARATTERISTICHE PRINCIPALI

HAMMER MECHANISM TIPO MASSE BATTENTI



3-jaw
3 griffe

ANVIL TYPE TIPO ALBERO



With ring, with hole
Con anello, con foro

AIR EXHAUST DIRECTION DIREZIONE SCARICO ARIA



Frontal
Frontale

HAMMER MECHANISM LUBRICATION LUBRIFICAZIONE MASSE BATTENTI



Grease
Grasso

BEST FOR APPLICAZIONI



Mine and oil field
Miniere e giacimenti



Construction site and shipyard
Cantieri e costruzioni navali



Industrial assembly
Montaggi industriali



Offshore platforms
Piattaforme offshore

Upgraded 3-jaw hammer mechanism
Masse battenti a 3 griffe perfezionate.

Ergonomic handle
Impugnatura ergonomica

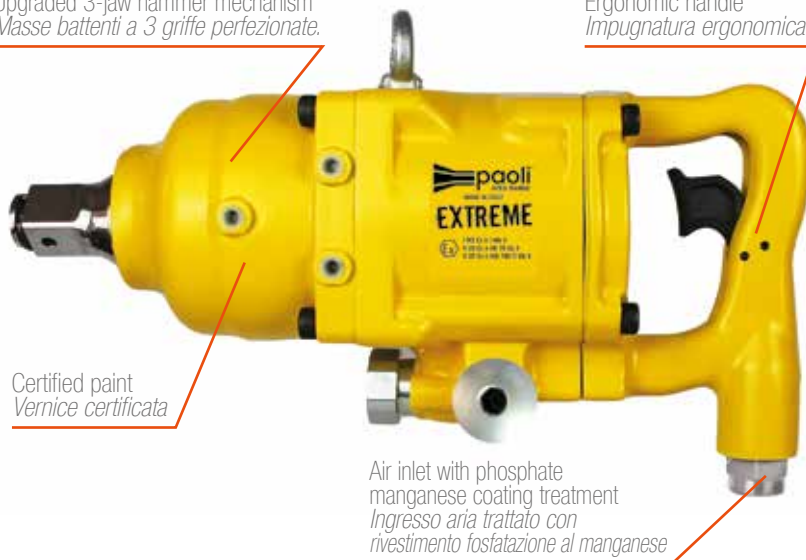

Certified paint
Vernice certificata

Air inlet with phosphate
manganese coating treatment
Ingresso aria trattato con
rivestimento fosfatazione al manganese

AVAILABLE MODELS MODELLI DISPONIBILI	PRODUCT CODE CODICE PRODOTTO	WEIGHT PESO	OUTER MATERIAL MATERIALE ESTERNO
 I M2 Ex h I Mb X II 2G EX h IIB T6 Gb X II 2D Ex h IIIB T85°C	A.07.31.0002	12,1 kg 26.67 lbs	Zama
 II 2G EX h IIB T6 Gb X II 2D Ex h IIIB T85°C	A.07.31.0003	9,48 kg 20.90 lbs	Aluminium

DP 362 BG ATEX

ATEX SERIES

1 1/2"



Square drive	<i>Attacco quadro</i>	1 1/2"
Bolt range	<i>Capacità bullone</i>	M24-M56
Max torque	<i>Coppia massima</i>	4200 Nm - 3100 ft-lb
Working torque	<i>Coppia raccomandata</i>	1200-2950 Nm - 880-2180 ft-lb
Free speed	<i>Velocità libera</i>	3200 rpm
Impacts number	<i>Numero impatti</i>	650/min
Working pressure	<i>Pressione di utilizzo</i>	6,3 bar - 91 psi
Air inlet	<i>Ingresso aria</i>	1/2" BSP
Inner hose diameter	<i>Diametro interno tubo</i>	13 mm - 0.512 in
Length	<i>Lunghezza</i>	421 mm - 16.6 in
Side to center	<i>Ingombro centro lato</i>	60 mm - 2.36 in
Vibration level - triaxial	<i>Livello vibrazioni - triassiale</i>	12,3 m/s ²
Sound pressure level	<i>Pressione sonora</i>	104 dB(A)



INCLUDED IN THE BOX INCLUSI NELLA SCATOLA



The package contains: lifting eye bolt, handle (in compliance with the CE UNI EN ISO 11148-6 norm), oil for impact wrench motors, operating and maintenance manual, after-sales suggestions.

La confezione contiene: golfare, maniglia (in conformità con la normativa CE UNI EN ISO 11148-6), olio per i motori degli avvitatori, manuale d'uso e manutenzione, indicazioni post-vendita.

MAIN FEATURES CARATTERISTICHE PRINCIPALI

HAMMER MECHANISM TIPO MASSE BATTENTI



3-jaw
3 griffe

ANVIL TYPE TIPO ALBERO



With ring, with hole
Con anello, con foro

AIR EXHAUST DIRECTION DIREZIONE SCARICO ARIA



Frontal
Frontale

HAMMER MECHANISM LUBRICATION LUBRIFICAZIONE MASSE BATTENTI



Grease
Grasso

BEST FOR APPLICAZIONI



Mine and oil field
Miniere e giacimenti



Construction site and shipyard
Cantieri e costruzioni navali





Industrial assembly
Montaggi industriali



Offshore platforms
Piattaforme offshore



AVAILABLE MODELS MODELLI DISPONIBILI	PRODUCT CODE CODICE PRODOTTO	WEIGHT PESO	OUTER MATERIAL MATERIALE ESTERNO
 I M2 Ex h I Mb X II 2G EX h IIB T6 Gb X II 2D Ex h IIB T85°C	A.07.41.0002	17,8 kg 39.2 lbs	Zama
 II 2G EX h IIB T6 Gb X II 2D Ex h IIB T85°C	A.07.41.0003	14,5 kg 32 lbs	Aluminium

MOBILE WORKING STATIONS

The range of Paoli Mobile Working Stations was born to protect the operators' safety and to ensure them an ergonomic and comfortable work station as well as to optimize work time and costs.

Advantages:

- no dust
- approximately 50% reduction of the perceived noise thanks to the silencers mounted on all our trolleys and to the displacement of the discharge point;
- reduction of the ergonomic risk level between 20% and 45% measured with recognized calculation systems such as the Niosh method.
- no weight in the operator's hands thanks to the suspension system integrated in the arm.

POSTAZIONI DI LAVORO MOBILE

La gamma di Postazione di Lavoro Mobile Paoli nasce dall'esigenza di salvaguardare la sicurezza dell'operatore e di assicurare allo stesso una postazione di lavoro ergonomica e confortevole e di ottimizzare tempi e costi di lavoro.

Vantaggi:

- *assenza di polveri nocive*
- *riduzione di circa il 50% della rumorosità percepita grazie ai silenziatori montati in tutti i carrelli e allo spostamento del punto di scarico;*
- *riduzione del livello di rischio ergonomico compresa tra il 20% e il 45% misurata con sistemi di calcolo riconosciuti come il metodo Niosh.*
- *nessun peso da sostenere grazie al braccio con sistema di sospensione integrato.*



**MOBILE WORKING STATIONS
POSTAZIONI DI LAVORO MOBILE**



- The exhaust air of the impact wrench is conveyed into a silencer mounted in the trolley, thus allowing:
 - a considerable reduction of acoustic pollution
 - the total absence of harmful dust and oily mists
 - The circuit is fitted with a pressure gauge, complete with lubricator and filter
 - It is on wheels for easy transportation
 - FRL group bypass
-
- *Lo scarico dell'avvitatore ad impulsi viene canalizzato in un silenziatore montato nel carrello, conseguentemente si ottiene:*
 - *una notevole riduzione dell'inquinamento acustico*
 - *la completa assenza di polveri nocive e di micro-nebbie oleose*
 - *Nel circuito è previsto un gruppo riduttore di pressione completo di lubrificatore e filtro*
 - *Facilità nel trasporto, dotato di ruote*
 - *Bypass del gruppo FRL*

Product code	<i>Codice prodotto</i>	C.02.0055
Weight	<i>Peso</i>	30 kg - 66.13 lbs
Overall dimensions	<i>Dimensioni d'ingombro</i>	400x635 mm - 15.75x25 in
Height	<i>Altezza</i>	920 mm - 36.22 in

PAOLI has invented a mobile work unit in order to improve the comfort and performance of professionals who work continuously with impact wrenches.

PAOLI ha inventato una postazione di lavoro mobile che permette di migliorare il comfort e le prestazioni dell'operatore professionale che deve lavorare con l'avvitatore ad impulsi in continuazione.

BEST FOR APPLICAZIONI



Heavy vehicles
Mezzi pesanti

AVAILABLE DISPONIBILE

C.02.0054
without air tank
senza serbatoio

WEIGHT 25.3 kg
PESO 55.77 lbs

Impact wrench support
Supporto per l'avvitatore



Socket holder
Portabussole

18 litre air tank
Serbatoio da 18 litri

Double hose
Doppio tubo

FRL Group
Filter-Regulator-Lubricator
*Gruppo FRL
Filtro-Regolatore-Lubrificatore*

Rear silencer filter
Filtro silenziatore sul retro



Impact wrench **NOT** included
*Avvitatore **NON** incluso*

MWS-SUSPENSION NAKED



The MWS-Suspension Naked work unit is characterized by:

- It is on wheels for easy transportation
- Continuous ordinary maintenance the pneumatic motor of the impact wrench

The Naked version includes:

- Large and comfortable seat in leather look material
- Reinforced carabiner
- Pulley balancer
- Lower and upper case box
- Lever compartment

La postazione di lavoro mobile MWS-Suspension Naked è caratterizzata da:

- *La facilità nel trasporto, dotato di ruote*
- *Manutenzione ordinaria continua al motore pneumatico dell'avvitatore*

La versione Naked include:

- *Larga e comoda seduta in materiale similpelle*
- *Moschettone rinforzato*
- *Bilanciatore a carrucola*
- *Vano porta oggetti sotto seduta e superiore*
- *Vano porta leve*

Product code	<i>Codice prodotto</i>	C.02.0067
Weight	<i>Peso</i>	53,5 kg - 117.94 lbs
Overall dimensions	<i>Dimensioni d'ingombro</i>	450x865 mm - 17,71x34.05 in
Height	<i>Altezza</i>	1935 mm - 76.18 in

PAOLI has invented a mobile work unit in order to allow operators to work whilst comfortably and ergonomically seated and at the same time avoiding the necessity to hold the impact wrench constantly thanks to a built-in suspension system in the arm, which can be rotated.

PAOLI ha inventato una postazione di lavoro mobile che permette all'operatore una posizione di seduta confortevole ed ergonomica e allo stesso tempo lo esenta dal sostenere l'avvitatore per tutto il tempo di lavoro grazie al sistema di sospensione integrato nel braccio girevole.

BEST FOR APPLICAZIONI



Heavy vehicles
Mezzi pesanti



MWS-SUSPENSION BASIC



The MWS-Suspension Basic work unit is characterized by:

- The exhaust air of the impact wrench is conveyed into a silencer mounted in the trolley, thus allowing:
 - a considerable reduction of acoustic pollution
 - the total absence of harmful dust and oily mists which are normally discharged and caused by the exhaust of the impact wrench near to the operator
- It is on wheels for easy transportation
- Continuous ordinary maintenance the pneumatic motor of the impact wrench

The Basic version includes:

- Large and comfortable seat in leather look material
- Reinforced carabiner
- Pulley balancer
- Lower and upper case box
- Lever compartment
- FRL Group and silencer filter

La postazione di lavoro mobile MWS-Suspension Basic è caratterizzata da:

- *Lo scarico dell'avvitatore ad impulsi viene canalizzato in un silenziatore montato nel carrello, conseguentemente si ottiene:*
 - *una notevole riduzione dell'inquinamento acustico*
 - *la completa assenza di polveri nocive e di micro-nebbie oleose normalmente sollevate e provocate dallo scarico dell'avvitatore nei pressi dell'operatore*
- *La facilità nel trasporto, dotato di ruote*
- *Manutenzione ordinaria continua al motore pneumatico dell'avvitatore*

La versione Basic include:

- *Larga e comoda seduta in materiale similpelle*
- *Moschettone rinforzato*
- *Bilanciatore a carrucola*
- *Vano porta oggetti sotto seduta e superiore*
- *Vano porta leve*
- *Gruppo FRL e filtro silenziatore*

Product code	<i>Codice prodotto</i>	C.02.0062
Weight	<i>Peso</i>	54,5 kg - 120.15 lbs
Overall dimensions	<i>Dimensioni d'ingombro</i>	450x865 mm - 17,71x34.05 in
Height	<i>Altezza</i>	1935 mm - 76.18 in

PAOLI has invented a mobile work unit in order to allow operators to work whilst comfortably and ergonomically seated and at the same time avoiding the necessity to hold the impact wrench constantly thanks to a built-in suspension system in the arm, which can be rotated.

PAOLI ha inventato una postazione di lavoro mobile che permette all'operatore una posizione di seduta confortevole ed ergonomica e allo stesso tempo lo esenta dal sostenere l'avvitatore per tutto il tempo di lavoro grazie al sistema di sospensione integrato nel braccio girevole.

BEST FOR APPLICAZIONI



Heavy vehicles
Mezzi pesanti



MWS-SUSPENSION COMPLETE



The MWS-Suspension Complete work unit is characterized by:

- The exhaust air of the impact wrench is conveyed into a silencer mounted in the trolley, thus allowing:
 - a considerable reduction of acoustic pollution
 - the total absence of harmful dust and oily mists which are normally discharged and caused by the exhaust of the impact wrench near to the operator
- It is on wheels for easy transportation
- Continuous ordinary maintenance for the pneumatic motor of the impact wrench

The Complete version includes:

- Large and comfortable seat in leather look material
- Reinforced carabiner
- Pulley balancer
- Upper case box
- Lever compartment
- FRL Group and silencer filter
- Front air tank under sitting

La postazione di lavoro mobile MWS-Suspension Complete è caratterizzata da:

- Lo scarico dell'avvitatore ad impulsi viene canalizzato in un silenziatore montato nel carrello, conseguentemente si ottiene:
 - una notevole riduzione dell'inquinamento acustico
 - la completa assenza di polveri nocive e di micro-nebbie oleose normalmente sollevate e provocate dallo scarico dell'avvitatore nei pressi dell'operatore
- La facilità nel trasporto, dotato di ruote
- Manutenzione ordinaria continua al motore pneumatico dell'avvitatore

La versione Complete include:

- Larga e comoda seduta in materiale similpelle
- Moschettone rinforzato
- Bilanciatore a carrucola
- Vano porta oggetti superiore
- Vano porta leve
- Gruppo FRL e filtro silenziatore
- Serbatoio aria anteriore sotto seduta

Product code	Codice prodotto	C.02.0063
Weight	Peso	54,5 kg - 120.15 lbs
Overall dimensions	Dimensioni d'ingombro	450x865 mm - 17,71x34.05 in
Height	Altezza	1935 mm - 76.18 in

PAOLI has invented a mobile work unit in order to allow operators to work whilst comfortably and ergonomically seated and at the same time avoiding the necessity to hold the impact wrench constantly thanks to a built-in suspension system in the arm, which can be rotated.

PAOLI ha inventato una postazione di lavoro mobile che permette all'operatore una posizione di seduta confortevole ed ergonomica ma allo stesso tempo lo esenta dal sostenere l'avvitatore per tutto il tempo di lavoro grazie al sistema di sospensione integrato nel braccio girevole.

BEST FOR APPLICAZIONI



Heavy vehicles
Mezzi pesanti

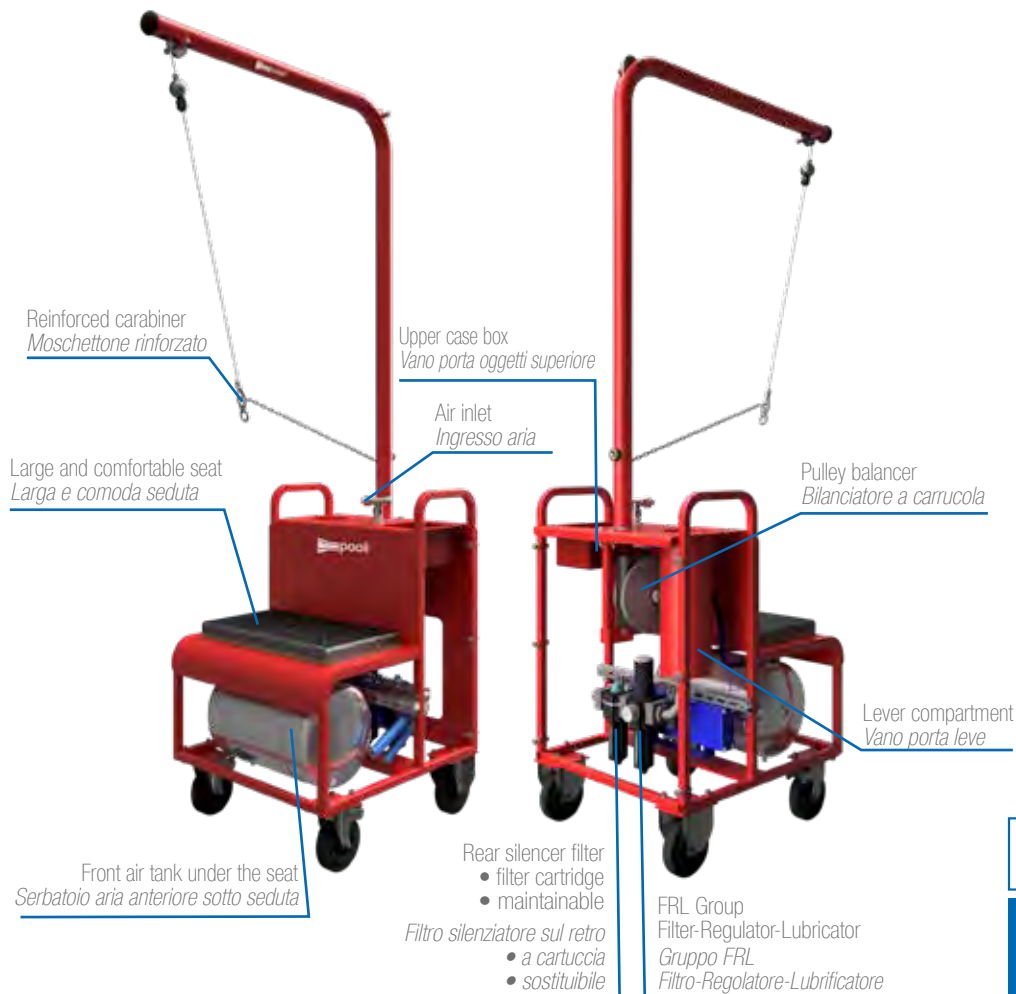

MWS-SUSPENSION FULL OPTIONAL



The MWS-Suspension Full Optional work unit is characterized by:

- The exhaust air of the impact wrench is conveyed into a silencer mounted in the trolley, thus allowing:
 - a considerable reduction of acoustic pollution
 - the total absence of harmful dust and oily mists which are normally discharged and caused by the exhaust of the impact wrench near to the operator
- It is on wheels for easy transportation
- Continuous ordinary maintenance for the pneumatic motor of the impact wrench

The Full Optional version includes:

- Large and comfortable seat in leather look material
- Reinforced carabiner
- Pulley balancer
- Upper case box
- Lever compartment
- FRL Group and silencer filter
- Front air tank under sitting
- Foot booster with filter

La postazione di lavoro mobile MWS-Suspension Full Optional è caratterizzata da:

- Lo scarico dell'avvitatore ad impulsi viene canalizzato in un silenziatore montato nel carrello, conseguentemente si ottiene:
 - una notevole riduzione dell'inquinamento acustico
 - la completa assenza di polveri nocive e di micro-nebbie oleose normalmente sollevate e provocate dallo scarico dell'avvitatore nei pressi dell'operatore
- La facilità nel trasporto, dotato di ruote
- Manutenzione ordinaria continua al motore pneumatico dell'avvitatore

La versione Full Optional include:

- Larga e comoda seduta in materiale similpelle
- Moschettone rinforzato
- Bilanciatore a carrucola
- Vano porta oggetti superiore
- Vano porta leve
- Gruppo FRL e filtro silenziatore
- Serbatoio aria anteriore sotto seduta
- Pedale booster con filtro

Product code	Codice prodotto	C.02.0064
Weight	Peso	56,5 kg - 124.56 lbs
Overall dimensions	Dimensioni d'ingombro	510x1100 mm - 20,08x43.31 in
Height	Altezza	1970 mm - 77.56 in

PAOLI has invented a mobile work unit in order to allow operators to work whilst comfortably and ergonomically seated and at the same time avoiding the necessity to hold the impact wrench constantly thanks to a built-in suspension system in the arm, which can be rotated.

PAOLI ha inventato una postazione di lavoro mobile che permette all'operatore una posizione di seduta confortevole ed ergonomica e allo stesso tempo lo esenta dal sostenere l'avvitatore per tutto il tempo di lavoro grazie al sistema di sospensione integrato nel braccio girevole.

BEST FOR APPLICAZIONI



Heavy vehicles
Mezzi pesanti



REGULAR SUPPLY SYSTEM KIT FOR EXTERNAL ASSISTANCE

KIT DI ALIMENTAZIONE PER ASSISTENZA ESTERNA

REGULAR SUPPLY SYSTEM KIT FOR EXTERNAL ASSISTANCE

The most obvious advantages are:

- with the 18 lt tank the supply pressure can be maintained always constant, thus granting the best start and precision of the impact wrench;
- the inlet of compressed air is controlled by a filter unit complete with lubricator and regulator;
- lightweight and assembled on a frame for easy transportation;
- fitted with impact wrench support.

Also available with FL Group (Filter-Lubricator), Code C.03.0001.

KIT DI ALIMENTAZIONE COSTANTE PER ASSISTENZA ESTERNA

I vantaggi più evidenti sono:

- *il serbatoio da 18 lt. permette di mantenere la pressione di alimentazione sempre costante e, quindi, di garantire lo spunto e precisione dell'avvitatore;*
- *la mandata dell'aria compressa è controllata con un gruppo filtro completo di lubrificatore e regolatore;*
- *è facilmente trasportabile perché leggero e montato su telaio;*
- *possiede un comodo supporto per l'avvitatore.*

Disponibile anche con Gruppo FL (Filtro-Lubrificatore), Cod. C.03.0001.

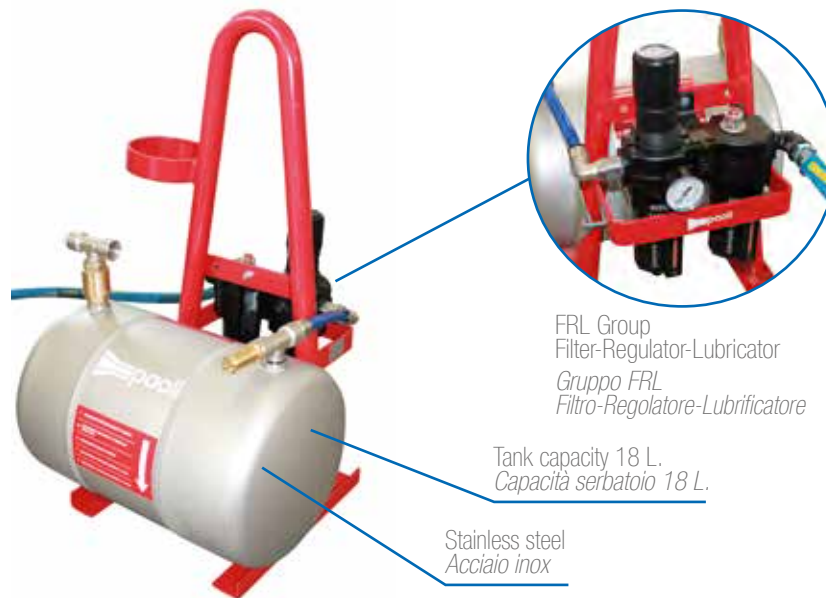

FRL Group
Filter-Regulator-Lubricator
Gruppo FRL
Filtro-Regolatore-Lubrificatore

Tank capacity 18 L.
Capacità serbatoio 18 L.

Stainless steel
Acciaio inox

Product code	Codice prodotto	C.03.0003
Weight	Peso	16 kg
Overall dimensions	Dimensioni d'ingombro	410x390 mm
Tank capacity	Capacità serbatoio	18 lt
Height	Altezza	660 mm
Safety valve calibration	Taratura valvola sicurezza	11 bar

AIR TREATMENT DEVICE FOR NUTRUNNERS GRUPPO TRATTAMENTO ARIA PER NUTRUNNERS

AIR TREATMENT FOR NUTRUNNERS

This system was designed for:

- performing a precise regulation of the tightening torque of the tool, by setting the proper air pressure supply;

It's fitted with a pressure filter and an air pressure regulator unit complete with lubricator.

GRUPPO TRATTAMENTO ARIA PER AVVITATORI A BRACCIO DI REAZIONE

È stato progettato e realizzato per:

- eseguire una precisa regolazione della coppia di serraggio dell'avvitatore, impostando la corretta pressione pneumatica di alimentazione;

È provvisto di un gruppo filtro-riduttore di pressione completo di lubrificatore.

Handle for easy transport
Maniglia per un facile trasporto



FRL Group
Filter-Regulator-Lubricator
Gruppo FRL
Filtro-Regolatore-Lubrificatore

Product code	Codice prodotto	B.46.02.0002
Weight	Peso	7,3 kg
Overall dimensions	Dimensioni d'ingombro	380 x 345 mm
Height	Altezza	355 mm

BALANCED ARTICULATED ARMS BRACCI ARTICOLATI BILANCIATI



The balanced articulated arms are designed to support and balance the weight of the tool.

- They remove the weight of the impact wrench reducing operator fatigue and increasing productivity.
- They allow a fluid and manageable movement in any direction
- They absorb couples and twists due to the use of tools

I bracci articolati bilanciati sono progettati per sostenere e bilanciare il peso dell'utensile.

- *Eliminano il peso dell'avvitatore riducendo la fatica dell'operatore e aumentando la produttività.*
- *Consentono un movimento fluido e maneggevole in ogni direzione*
- *Assorbono coppie e torsioni dovute all'utilizzo di utensili*

Product code <i>Codice prodotto</i>	Ray work area <i>Raggio di lavoro</i>	Structure <i>Struttura</i>	Coppia max <i>Max torque</i>	Tool weight <i>Peso Utensile</i>	Arm weight <i>Peso braccio</i>
G.03.01.0008	1290 mm	Double arm <i>Doppio braccio</i>	120 Nm	1,5 - 3 kg	14 kg
G.03.01.0009	1290 mm	Double arm <i>Doppio braccio</i>	120 Nm	3,5 - 6 kg	14,5 kg
G.03.01.0010	1290 mm	Double arm <i>Doppio braccio</i>	150 Nm	6,5 - 10 kg	15,5 kg
G.03.01.0011	1290 mm	Double arm <i>Doppio braccio</i>	150 Nm	11 - 14 kg	16 kg
G.03.01.0012	1290 mm	Double arm <i>Doppio braccio</i>	200 Nm	7 - 10 kg	18 kg
G.03.01.0013	1290 mm	Double arm <i>Doppio braccio</i>	200 Nm	10 - 14 kg	18 kg
G.03.01.0014	1290 mm	Double arm <i>Doppio braccio</i>	200 Nm	15 - 19 kg	20 kg
G.03.01.0015	1290 mm	Double arm <i>Doppio braccio</i>	200 Nm	20 - 30 kg	30 kg

BALANCED ARTICULATED ARMS BRACCI ARTICOLATI BILANCIATI

TOOL HEADS MORSETTO



DPHA40

DPTH80

Product name Nome prodotto	Ø	For Ø smaller than Per Ø inferiori a
DPTH40	40 mm	-
DPTH60	60 mm	-
DPTH80	80 mm	-
DPHA40	-	40 mm
DPHA60	-	60 mm
DPHA80	-	80 mm

MULTI-DIRECTIONAL HEAD TESTINA MULTI-DIREZIONALE



DPTHM

EXCLUDED ESCLUSO:

G.03.01.0015, G.03.02.0009, G.03.02.0010,
G.03.02.0010



G.03.01.0008
Double articulated arm
Doppio braccio articolato.



G.03.02.0004
Triple articulated arm
Tripo braccio articolato.

Product code Codice prodotto	Work area Raggio di lavoro	Structure Struttura	Coppia max Max torque	Tool weight Peso Utensile	Arm weight Peso braccio
G.03.02.0004	1900 mm	Triple arm <i>Tripo braccio</i>	120 Nm	1,5 - 2,5 kg	16 kg
G.03.02.0005	1900 mm	Triple arm <i>Tripo braccio</i>	120 Nm	2,5 - 5 kg	16 kg
G.03.02.0006	1900 mm	Triple arm <i>Tripo braccio</i>	180 Nm	5,5 - 8 kg	17 kg
G.03.02.0007	1900 mm	Triple arm <i>Tripo braccio</i>	250 Nm	8,5 - 11 kg	17 kg
G.03.02.0012	1900 mm	Triple arm <i>Tripo braccio</i>	250 Nm	11,5 - 15 kg	17 kg
G.03.02.0003	1900 mm	Triple arm <i>Tripo braccio</i>	250 Nm	16 - 20 kg	18 kg
G.03.02.0008	1900 mm	Triple arm <i>Tripo braccio</i>	300 Nm	21 - 25 kg	20 kg
G.03.02.0009	1600 mm	Triple arm <i>Tripo braccio</i>	500 Nm	26 - 30 kg	50 kg
G.03.02.0010	1600 mm	Triple arm <i>Tripo braccio</i>	500 Nm	31 - 35 kg	50 kg
G.03.02.0011	1600 mm	Triple arm <i>Tripo braccio</i>	500 Nm	36 - 40 kg	50 kg

TROLLEYS FOR ARTICULATED ARMS CARRELLI PER BRACCI ARTICOLATI

The trolleys are designed to support and easily transport the articulated arm.

- 4 turning wheels - 2 with brakes
- pushing handle
- counterweight for double arm

Advantages for the operator:

- Possibility of using a mobile work unit.
- No weight in the hands

I carrelli sono progettati per sostenere e trasportare facilmente il braccio articolato.

- 4 ruote girevoli di cui 2 con freno
- maniglione di spinta
- contrappeso per doppio braccio

Vantaggi per l'operatore:

- Possibilità di usufruire di una postazione di lavoro mobile.
- Nessun peso da sostenere

DPCA5

G.03.03.0006

Model with lifting column
(h: 2000 mm)

Modello con colonna di sollevamento (h=2000mm)



DPCA7

G.03.03.0007



Product name <i>Product name</i>	Product code <i>Codice prodotto</i>	Base dimensions <i>Dimensioni del basamento</i>	Weight <i>Peso</i>
DPCA5	G.03.03.0006	800X800x30 mm	220 kg
DPCA7	G.03.03.0007	800X800X30 mm	155 kg

TROLLEYS FOR ARTICULATED ARMS CARRELLI PER BRACCI ARTICOLATI



G.03.03.0011

Model in painted steel with lower storage shelf
4 swivel wheels, 2 brakes

*Modello in acciaio verniciato con ripiano inferiore portaoggetti
4 ruote girevoli, 2 freni*



G.03.03.0012

Model with central column for arm support with adjustable height from
650mm to 1050mm
4 turning wheels, 2 brakes

*Modello con colonna centrale sostegno braccio con altezza regolabile
da 650mm a 1050mm
4 ruote girevoli, 2 freni*

Product name <i>Nome prodotto</i>	Product code <i>Codice prodotto</i>	Base dimensions <i>Dimensioni del basamento</i>	Weight <i>Peso</i>
DPCA1	G.03.03.0011	850X750x870 mm	65 kg
DPCA4	G.03.03.0012	800X800X30 mm	165 kg

ELECTRO-HYDRAULIC RANGE

WITH ELECTRIC BUTTONS

Paoli's experience and know-how has led to the development of a revolutionary and reliable electro-hydraulic range.

When air supply is not available, Paoli power units and electro-hydraulic impact wrenches become an irreplaceable work tool. Essential for industrial assembly, they are fitted to be used in construction sites, mobile workshops, infrastructures maintenance and roadside assistance. Paoli electro-hydraulic systems are perfect for situations where all the air supplies are already being used by other tools.

Paoli electro-hydraulic systems are easy to use: it is sufficient to connect the control unit to a power outlet or to a generator. The power supply system, consisting of only two flexible hoses, is also extremely user-friendly.

GAMMA ELETTRO-IDRAULICA

CON PULSANTI ELETTRICI

L'esperienza e il know-how di Paoli hanno permesso di sviluppare un gamma elettro-idraulica rivoluzionaria e affidabile.

Quando non è disponibile l'alimentazione ad aria, le centraline e gli avvitatori elettro-idraulici Paoli diventano uno strumento di lavoro insostituibile. Indispensabili per gli assemblaggi industriali, sono idonei all'uso in cantieri edili, officine mobili, manutenzione di infrastrutture e soccorso stradale. I sistemi elettro-idraulici Paoli sono perfetti in tutti quei casi in cui gli impianti di distribuzione d'aria risultano già totalmente impegnati da altri utensili.

I sistemi elettro-idraulici Paoli sono molto semplici da utilizzare: è sufficiente collegare la centralina ad una presa di corrente o a un generatore. Il sistema di alimentazione, composto soltanto da due tubi flessibili, risulta inoltre estremamente maneggevole per l'utente.



ELECTRO-HYDRAULIC RANGE GAMMA ELETTRO-IDRAULICA

**WITH ELECTRIC BUTTONS
CON PULSANTI ELETTRICI**

ELECTRO-HYDRAULIC IMPACT WRENCHES

WITH ELECTRIC BUTTONS

AVVITATORI ELLETTRO-IDRAULICI

CON PULSANTI ELETTRICI



Paoli electro-hydraulic impact wrenches are equipped with an economic and ecological system: you consume energy only when you use the impact wrench. The hydraulic mechanism also allows torque repeatability and higher torque compared to pneumatic models of equal weight.

Gli avvitatori elettro-idraulici Paoli sono dotati di un sistema economico ed ecologico: si consuma energia soltanto quando si usa l'avvitatore. Il funzionamento a olio permette inoltre la ripetibilità di coppia e una coppia più elevata rispetto ai modelli pneumatici di pari peso.

Product name <i>Nome prodotto</i>	DPH 340	DPH 340 AL*	DPH 341	DPH 341 AL*	DPH 351	DPH 351 AL*
Product code <i>Codice prodotto</i>	A.03.02.0019	A.03.02.0018	A.03.02.0017	A.03.02.0016	A.03.02.0022	A.03.02.0024
Square drive <i>Attacco quadro</i>	3/4"			1"		
Bolt range <i>Capacità bullone</i>	M14-M24		M18-M33		M18-M36	
Max torque <i>Coppia massima</i>	3000 Nm - 2220 ft-lb				5000 Nm - 3688 ft-lb	
Weight <i>Peso</i>	6,83 kg 15.1 lbs	7,49 Kg 16.5 lbs	6,90 kg 15.2 lbs	7,57 kg 16.7 lbs	9,30 kg 20.5 lbs	10 kg 22 lbs
Free speed <i>Velocità libera</i>	2800 rpm				1700 rpm	
Max oil flow <i>Portata massima olio</i>	10 l/min					
Length <i>Lunghezza</i>	282 mm 11.1 in	395 mm 15.5 in	286 mm 11.2 in	432 mm 17.0 in	320 mm 12.6 in	457 mm 18.0 in
Side to center <i>Ingombro centro lato</i>	47,5 mm 1.87 in				55 mm 2.16 in	

*AL = Long anvil model

*AL = modello ad albero lungo

MAIN FEATURES CARATTERISTICHE PRINCIPALI

HAMMER MECHANISM TIPO MASSE BATTENTI



ANVIL TYPE TIPO ALBERO



HAMMER MECHANISM LUBRICATION LUBRIFICAZIONE MASSE BATTENTI



BEST FOR APPLICAZIONI

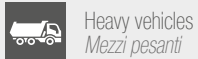

Motor cover with heat dissipation
Cuffia coperchio motore con dissipazione calore



Ergonomic handle with integrated oil flow
Impugnatura ergonomica con passaggio olio integrato

Handle made entirely in Ergal
Impugnatura interamente in Ergal

Electric cable quick connector
Connettore rapido per cavo elettrico

Oil quick connectors
innesti rapidi per olio

DYNO

ELECTRO-HYDRAULIC UNIT

GAMMA ELLETRO-IDRAULICA CON PULSANTI ELETTRICI



Ideal for: mechanical and industrial workshops, road services, infrastructures, railway and oil and gas applications. Perfect when no air supply is available.

- Low voltage electrical control of the impact wrench: maximum operator safety
- Torque control: adjustable tightening torque from 300 to 4000 Nm, maximum power on loosening 5000 Nm.

Ideale per: officine meccaniche e industriali, servizio assistenza su strada, infrastrutture e applicazioni ferroviarie, olio e gas. Perfetto quando non si dispone di alimentazione d'aria compressa.

- *Comandi elettrici a bassa tensione: massima sicurezza per l'operatore*
- *Controllo di coppia: coppia di serraggio registrabile da 300 a 4000 Nm in avvitamento, coppia massima in svitamento fino a 5000 Nm, per i dadi più resistenti.*

Product name	<i>Nome prodotto</i>	DYNO
Product code	<i>Codice prodotto</i>	D.04.01.0004
Weight	<i>Peso</i>	60 kg - 132 lbs
Power	<i>Potenza</i>	2.2 kW
Tension	<i>Tensione</i>	220/400 v trifase - 50/60 Hz

AVAILABLE KITS KIT DISPONIBILI

Every kit includes: DYNO, impact wrench and standard hose.
Ogni kit include: DYNO, avvitatore e tubo standard.



Kit name <i>Nome Kit</i>	DYNO 1	DYNO 2	DYNO 3	DYNO 4	DYNO 5	DYNO 6
Product code <i>Codice prodotto</i>	A.03.01.0005	A.03.01.0006	A.03.01.0007	A.03.01.0008	A.03.01.0019	A.03.01.0020
Impact wrench <i>Avvitatore</i>	DPH 340	DPH 340 AL	DPH 341	DPH 341 AL	DPH 351	DPH 351 AL

MAIN FEATURES CARATTERISTICHE PRINCIPALI

TABELLA PRESSIONE-COPPIA AVVITAMENTO
TABLEAU PRESSION-COUPLE DE SERRAGE
PRESSURE-TIGHTENING TORQUE TABLE

Pressione Pressure [bar]	Coppia/Couple/Torque [Nm] ± 5%	
	Dado/Errore/Bit M22x1.5	Dado/Errore/Bit M22x1.5
60	295	314
70	373	382
80	422	436
90	490	510
100	549	566
110	578	627
120	635	684
130	682	741
140	734	798
150	780	855
160	835	912
170	887	969
180	940	997
190	991	1082
200	1042	1100

Tempo di avvitamento: 5 sec.
Tempo di serraggio / Tightening time: 5 sec.

Tightening time: 5 seconds
Tempo di avvitamento: 5 secondi

BEST FOR APPLICAZIONI



Infrastructures
Infrastrutture



Industrial assembly
Montaggi industriali

Selector for the inversion of phase:
Allows to use the control unit to
any electrical outlet

*Selettore di Fase:
permette di utilizzare la centralina
su qualsiasi presa di corrente trifase*

Thermal relay:
protects the electric motor

*Relè termico:
protegge il motore termico*

New impact wrench supply
with just 2 flexible hoses

*Alimentazione innovativa
dell'avvitatore con solo
2 tubi flessibili*

Lateral handles suitable
for transportation or
manual lifting

*Impugnature laterali
idonee per il trasporto
o sollevamento manuale*

Pressure-tightening torque table
*Tabella pressione-coppia
avvitamento**



Impact wrench NOT included
Avvitatore NON incluso

ELECTRO-HYDRAULIC RANGE

WITH MECHANICAL LEVER

Thanks to the experience gained from the Electro-Hydraulic Range with electrical buttons, Paoli evolves and offers even more reliable and robust products. An innovative range, which substitute electrical button actuation with a mechanical lever and a manual inverter, preventing electrical risks, in increasingly challenging professional applications both from the logistic and environmental point of view. The electro-hydraulic range is renewed and widened, improving all its components and allowing it to cover any work use in safety and ensuring the performance that has always distinguished the Dino Paoli impact wrenches.

GAMMA ELETTRO-IDRAULICA

CON LEVA MECCANICA

Grazie all'esperienza acquisita dalla gamma elettro-idraulica con pulsanti elettrici, Paoli si evolve e offre un prodotto ancora più affidabile e robusto. Una gamma innovativa, che esclude l'avviamento e l'inversione tramite l'utilizzo di pulsanti ad alimentazione elettrica e li sostituisce con una leva meccanica, evitando così tutti i rischi connessi all'elettricità, in applicazioni professionali sempre più sfidanti sia dal punto di vista logistico che ambientale. La gamma elettro-idraulica si rinnova e si amplia, migliorandosi in tutte le sue componenti e consentendo di coprire tutti i contesti di lavoro in sicurezza e garantendo le prestazioni che da sempre contraddistinguono gli avvitatori Dino Paoli.



ELECTRO-HYDRAULIC RANGE GAMMA IDRAULICA

WITH MECHANICAL LEVER
CON LEVA MECCANICA

DPH 340 M

AVVITATORI ELETTRO-IDRAULICI CON LEVA MECCANICA



Ideal for: mechanical and industrial workshops, infrastructures and railway applications, oil&gas, mining and cold workplaces when no air supply is available.

- Torque control: adjustable torque up to 3000 Nm, for the hardest bolts.

Ideale per: officine meccaniche e industriali, infrastrutture e applicazioni ferroviarie, oil&gas, miniera e ambienti di lavoro freddi quando non si dispone di alimentazione d'aria compressa.

- *Controllo di coppia: coppia di serraggio registrabile fino a 3000 Nm, per i dadi più resistenti.*

Product name	<i>Nome prodotto</i>	DPH 340 M
Product code	<i>Codice prodotto</i>	A.03.02.0033
Square drive	<i>Attacco quadro</i>	3/4"
Bolt range	<i>Capacità bullone</i>	M14-M24
Max torque	<i>Coppia massima</i>	3000 Nm - 2220 ft-lb
Weight	<i>Peso</i>	7,6 Kg- 16.7 lbs
Free speed	<i>Velocità libera</i>	2800 rpm
Max oil flow	<i>Portata massima olio</i>	10 l/min
Length	<i>Lunghezza</i>	421 mm - 16.6 in
Side to center	<i>Ingombro centro lato</i>	62 mm - 2.45 in

MAIN FEATURES CARATTERISTICHE PRINCIPALI

HAMMER MECHANISM TIPO MASSE BATTENTI



3-jaw
3 griffe

ANVIL TYPE TIPO ALBERO



With ring, without hole
Con anello, senza foro

HAMMER MECHANISM LUBRICATION LUBRIFICAZIONE MASSE BATTENTI



Grease
Grasso

BEST FOR APPLICAZIONI



Infrastructures
Infrastrutture



Mine and oil field
Miniere e giacimenti



Construction site and shipyard
Cantieri e costruzioni navali

3-jaw hammer mechanism type
*Tipologia di meccanismo ad impulso a
sistema ad alzata di camma a 3 griffe*

Motor cover with heat dissipation
Cuffia coperchio motore con dissipazione calore

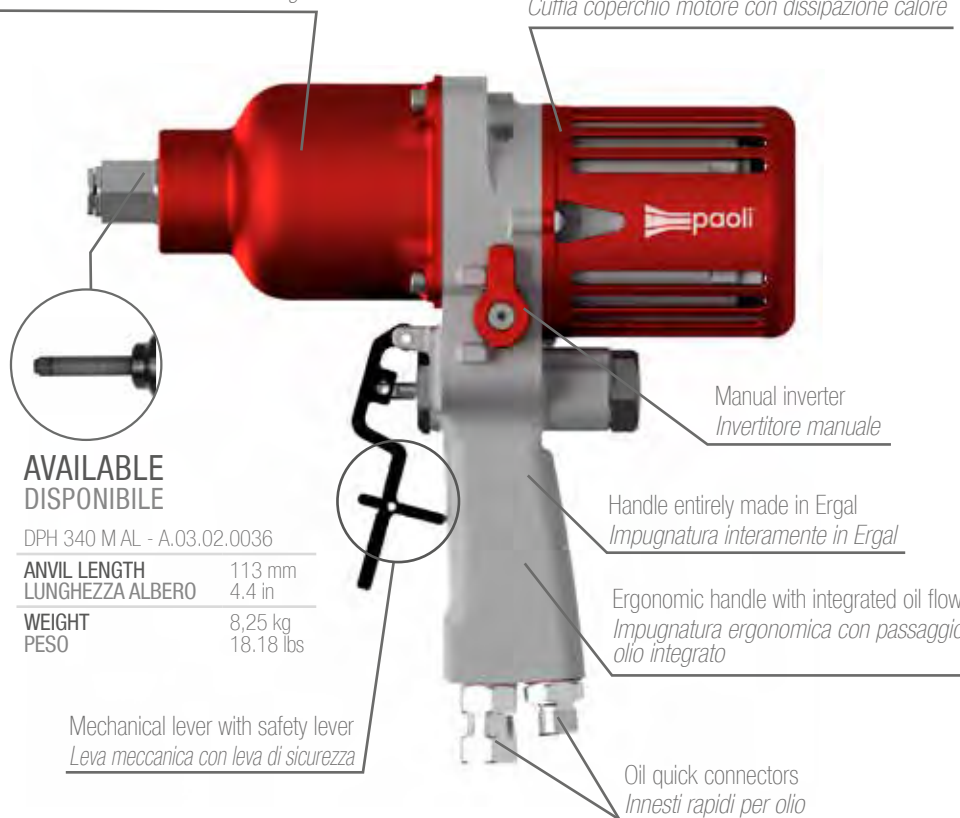

AVAILABLE DISPONIBILE

DPH 340 M AL - A.03.02.0036

ANVIL LENGTH LUNGHEZZA ALBERO	113 mm 4.4 in
----------------------------------	------------------

WEIGHT PESO	8,25 kg 18.18 lbs
----------------	----------------------

Mechanical lever with safety lever
Leva meccanica con leva di sicurezza

Manual inverter
Invertitore manuale

Handle entirely made in Ergal
Impugnatura interamente in Ergal

Ergonomic handle with integrated oil flow
*Impugnatura ergonomica con passaggio
olio integrato*

Oil quick connectors
Innesti rapidi per olio

 paoli

DPH 341 M

AVVITATORI IDRAULICI CON LEVA MECCANICA



Ideal for: mechanical and industrial workshops, infrastructures and railway applications, oil&gas, mining and cold workplaces when no air supply is available.

- Torque control: adjustable torque up to 3000 Nm, for the hardest bolts.

Ideale per: officine meccaniche e industriali, infrastrutture e applicazioni ferroviarie, oil&gas, miniera e ambienti di lavoro freddi quando non si dispone di alimentazione d'aria compressa.

- *Controllo di coppia: coppia di serraggio registrabile fino a 3000 Nm, per i dadi più resistenti.*

Product name	<i>Nome prodotto</i>	DPH 341 M
Product code	<i>Codice prodotto</i>	A.03.02.0032
Square drive	<i>Attacco quadro</i>	1"
Bolt range	<i>Capacità bullone</i>	M18-M33
Max torque	<i>Coppia massima</i>	3000 Nm - 2220 ft-lb
Weight	<i>Peso</i>	7,7 Kg - 16.9 lbs
Free speed	<i>Velocità libera</i>	2800 rpm
Max oil flow	<i>Portata massima olio</i>	10 l/min
Length	<i>Lunghezza</i>	288,8 mm - 11.37 in
Side to center	<i>Ingombro centro lato</i>	57 mm - 2.24 in

MAIN FEATURES CARATTERISTICHE PRINCIPALI

HAMMER MECHANISM TIPO MASSE BATTENTI



3-jaw
3 griffe

ANVIL TYPE TIPO ALBERO



With ring, with hole
Con anello, con foro

HAMMER MECHANISM LUBRICATION LUBRIFICAZIONE MASSE BATTENTI



Grease
Grasso

BEST FOR APPLICAZIONI



Infrastructures
Infrastrutture



Mine and oil field
Miniere e giacimenti



Construction site and shipyard
Cantieri e costruzioni navali

3-jaw hammer mechanism type
Tipologia di meccanismo ad impulso a sistema ad alzata di camma a 3 griffe

Motor cover with heat dissipation
Cuffia coperchio motore con dissipazione calore

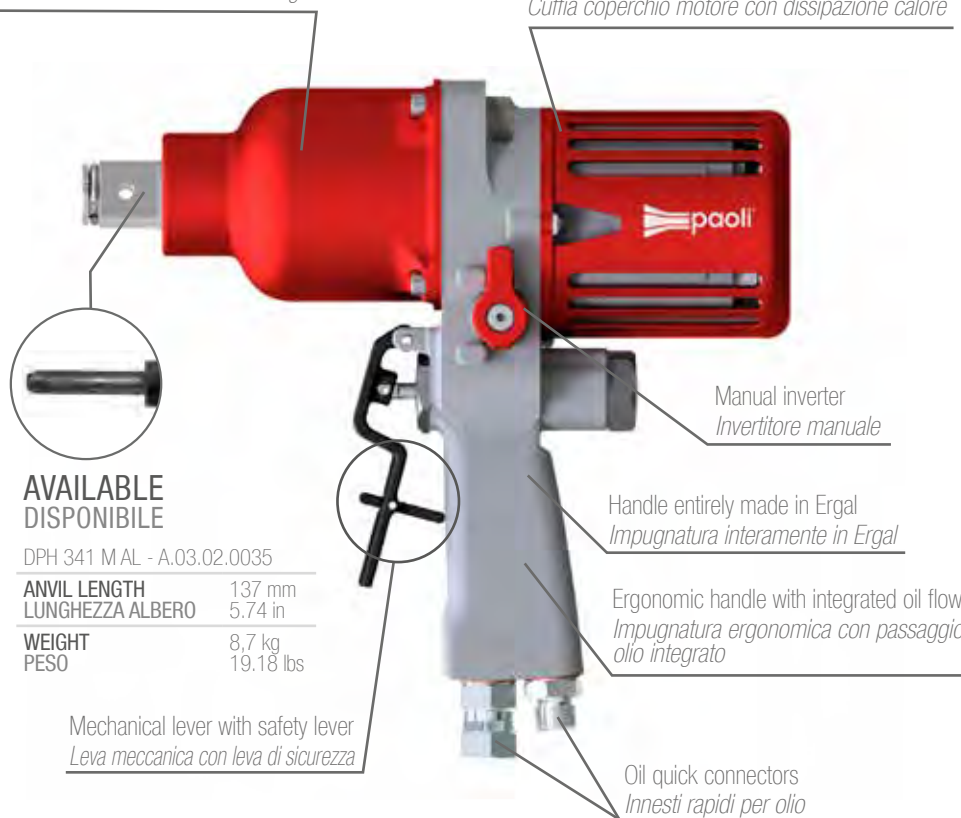

AVAILABLE DISPONIBILE

DPH 341 M AL - A.03.02.0035

ANVIL LENGTH LUNGHEZZA ALBERO	137 mm 5.74 in
----------------------------------	-------------------

WEIGHT PESO	8,7 kg 19.18 lbs
----------------	---------------------

Mechanical lever with safety lever
Leva meccanica con leva di sicurezza

Manual inverter
Invertitore manuale

Handle entirely made in Ergal
Impugnatura interamente in Ergal

Ergonomic handle with integrated oil flow
Impugnatura ergonomica con passaggio olio integrato

Oil quick connectors
Innesti rapidi per olio

paoli

DPH 351 M

AVVITATORI IDRAULICI CON LEVA MECCANICA



Ideal for: mechanical and industrial workshops, infrastructures and railway applications, oil&gas, mining and cold workplaces when no air supply is available.

- Torque control: adjustable torque up to 5000 Nm, for the hardest bolts.

Ideale per: officine meccaniche e industriali, infrastrutture e applicazioni ferroviarie, oil&gas, miniera e ambienti di lavoro freddi quando non si dispone di alimentazione d'aria compressa.

- *Controllo di coppia: coppia di serraggio registrabile fino a 5000 Nm, per i dadi più resistenti.*

Product name	<i>Nome prodotto</i>	DPH 351 M
Product code	<i>Codice prodotto</i>	A.03.02.0025
Square drive	<i>Attacco quadro</i>	1"
Bolt range	<i>Capacità bullone</i>	M18-M36
Max torque	<i>Coppia massima</i>	5000 Nm - 3688 ft-lb
Weight	<i>Peso</i>	8,8 Kg - 19.4 lbs
Free speed	<i>Velocità libera</i>	1700 rpm
Max oil flow	<i>Portata massima olio</i>	10 l/min
Length	<i>Lunghezza</i>	323,4 mm - 12.7 in
Side to center	<i>Ingombro centro lato</i>	57 mm - 2.24 in

MAIN FEATURES CARATTERISTICHE PRINCIPALI

HAMMER MECHANISM TIPO MASSE BATTENTI



3-jaw
3 griffe

ANVIL TYPE TIPO ALBERO



With ring, without hole
Con anello, con foro

HAMMER MECHANISM LUBRICATION LUBRIFICAZIONE MASSE BATTENTI



Grease
Grasso

BEST FOR APPLICAZIONI



Infrastructures
Infrastrutture



Mine and oil field
Miniere e giacimenti



Construction site and shipyard
Cantieri e costruzioni navali

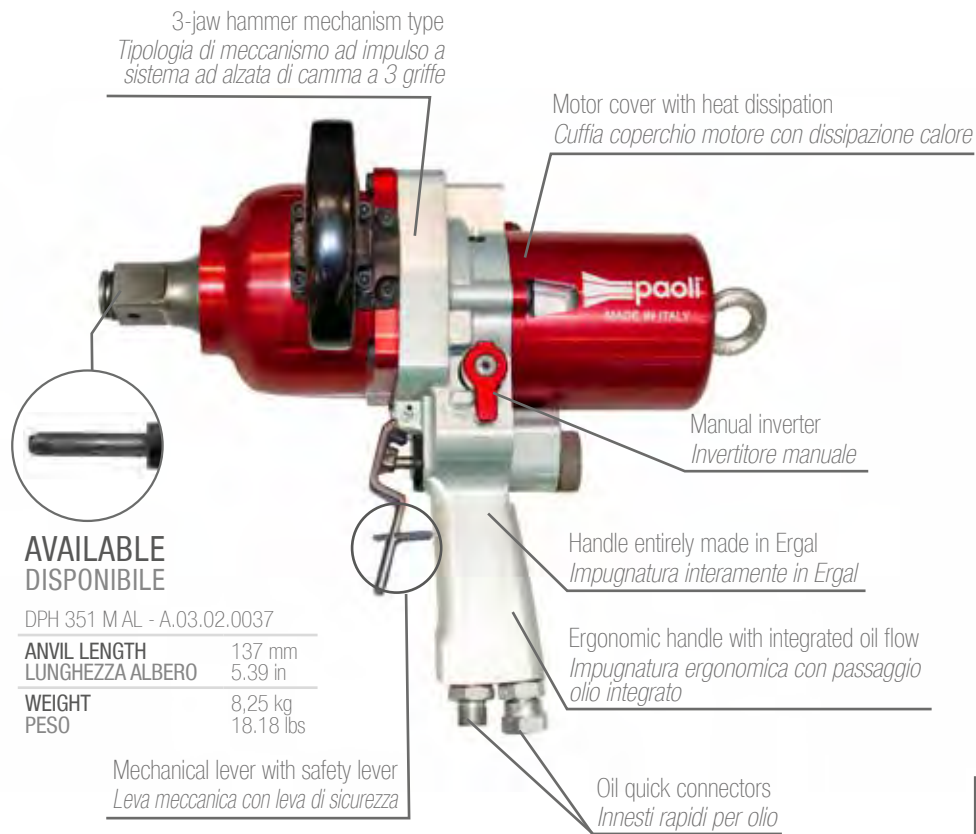

DPH 362

AVVITATORI IDRAULICI CON LEVA MECCANICA



Ideal for: mechanical and industrial workshops, infrastructures and railway applications, oil&gas, mining and cold workplaces when no air supply is available.

- Torque control: adjustable torque up to 9500 Nm, for the hardest bolts.

Ideale per: officine meccaniche e industriali, infrastrutture e applicazioni ferroviarie, oil&gas, miniera e ambienti di lavoro freddi quando non si dispone di alimentazione d'aria compressa.

- *Controllo di coppia: coppia di serraggio registrabile fino a 9500 Nm, per i dadi più resistenti.*

Product name	<i>Nome prodotto</i>	DPH 362
Product code	<i>Codice prodotto</i>	A.03.02.0031
Square drive	<i>Attacco quadro</i>	1½"
Bolt range	<i>Capacità bullone</i>	M24-M56
Max torque	<i>Coppia massima</i>	9500 Nm - 7007 ft-lb
Weight	<i>Peso</i>	13,6 kg - 29,98 lbs
Free speed	<i>Velocità libera</i>	1350 rpm
Max oil flow	<i>Portata massima olio</i>	10 l/min
Length	<i>Lunghezza</i>	363 mm - 14.29 in
Side to center	<i>Ingombro centro lato</i>	60 mm - 2.36 in

MAIN FEATURES CARATTERISTICHE PRINCIPALI

HAMMER MECHANISM TIPO MASSE BATTENTI



3-jaw
3 griffe

ANVIL TYPE TIPO ALBERO



Without ring, with hole
Senza anello, con foro

HAMMER MECHANISM LUBRICATION LUBRIFICAZIONE MASSE BATTENTI



Grease
Grasso

BEST FOR APPLICAZIONI



Infrastructures
Infrastrutture



Mine and oil field
Miniere e giacimenti



Construction site and shipyard
Cantieri e costruzioni navali

3-jaw hammer mechanism type
Tipologia di meccanismo ad impulso a sistema ad alzata di camma a 3 griffe

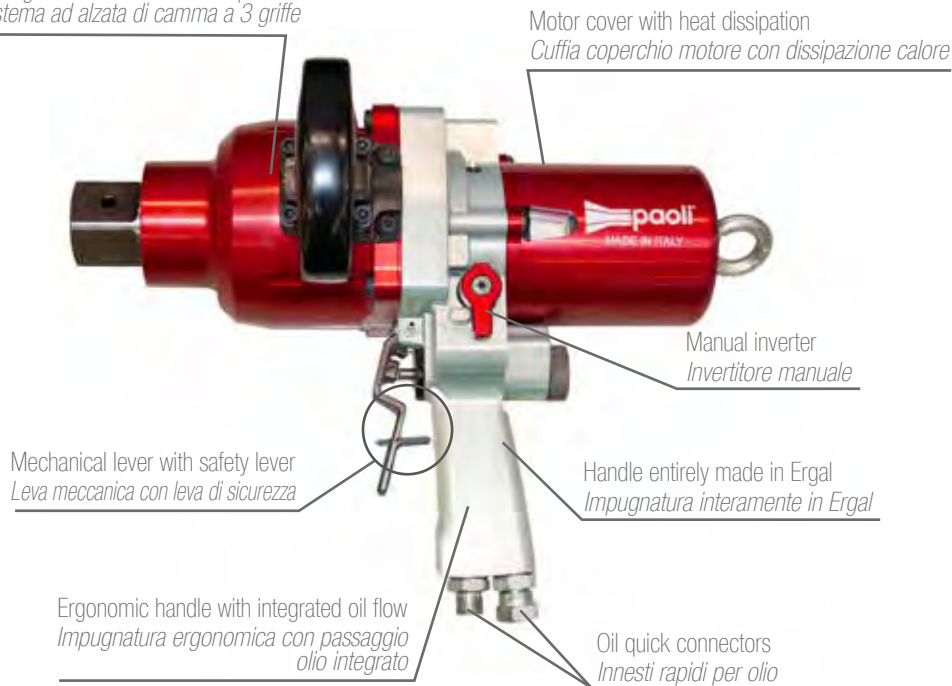

Motor cover with heat dissipation
Cuffia coperchio motore con dissipazione calore

Manual inverter
Invertitore manuale

Handle entirely made in Ergal
Impugnatura interamente in Ergal

Mechanical lever with safety lever
Leva meccanica con leva di sicurezza

Ergonomic handle with integrated oil flow
Impugnatura ergonomica con passaggio olio integrato

Oil quick connectors
Innesti rapidi per olio

DPH 381

AVVITATORI IDRAULICI CON LEVA MECCANICA



Ideal for: mechanical and industrial workshops, infrastructures and railway applications, oil&gas, mining and cold workplaces when no air supply is available.

- Torque control: adjustable torque up to 17000 Nm, for the hardest bolts.

Ideale per: officine meccaniche e industriali, infrastrutture e applicazioni ferroviarie, oil&gas, miniera e ambienti di lavoro freddi quando non si dispone di alimentazione d'aria compressa.

- *Controllo di coppia: coppia di serraggio registrabile fino a 17000 Nm, per i dadi più resistenti.*

Product name	<i>Nome prodotto</i>	DPH 381
Product code	<i>Codice prodotto</i>	A.03.02.0034
Square drive	<i>Attacco quadro</i>	1½"
Bolt range	<i>Capacità bullone</i>	M30-M80
Max torque	<i>Coppia massima</i>	17000 Nm - 12538.56 ft-lb
Weight	<i>Peso</i>	22,7 kg - 50.04 lbs
Free speed	<i>Velocità libera</i>	1200 rpm
Max oil flow	<i>Portata massima olio</i>	10 l/min
Length	<i>Lunghezza</i>	496 mm - 19.52 in
Side to center	<i>Ingombro centro lato</i>	88,7 mm - 3,4 in

MAIN FEATURES CARATTERISTICHE PRINCIPALI

HAMMER MECHANISM TIPO MASSE BATTENTI



3-jaw
3 griffe

ANVIL TYPE TIPO ALBERO



Without ring, with hole
Senza anello, con foro

HAMMER MECHANISM LUBRICATION LUBRIFICAZIONE MASSE BATTENTI



Grease
Grasso

BEST FOR APPLICAZIONI



Infrastructures
Infrastrutture



Mine and oil field
Miniere e giacimenti



Construction site and shipyard
Cantieri e costruzioni navali

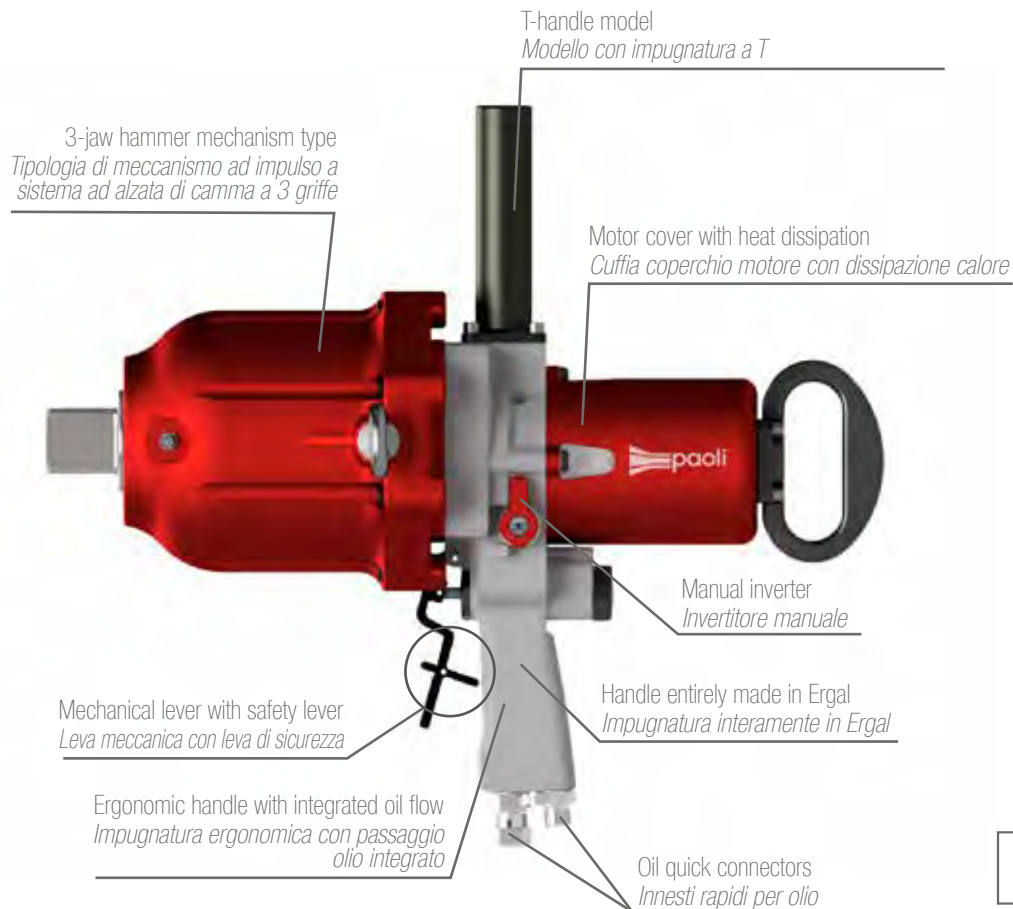

DYNO-M

GAMMA IDRAULICA CON LEVA MECCANICA



Ideal for: mechanical and industrial workshops, road services, infrastructures and railway applications, oil&gas, mining and cold workplaces when no air supply is available.

- Torque control: adjustable torque up to 17000 Nm, for the hardest bolts.

Ideale per: officine meccaniche e industriali, servizio assistenza su strada, infrastrutture e applicazioni ferroviarie, oil&gas, miniera e ambienti di lavoro freddi quando non si dispone di alimentazione d'aria compressa.

- *Controllo di coppia: coppia di serraggio registrabile fino a 17000 Nm, per i dadi più resistenti.*

Product name Nome prodotto	DYNO 1 (M)	DYNO 2 (M)	DYNO 3 (M)	DYNO 4 (M)	DYNO 5 (M)	DYNO 6 (M)	DYNO 7 (M)	DYNO 8 (M)
Power Potenza				3 hp 2.2 kW			5,5 hp 4 kW	7,5 hp 5.5 kW
Tension (European) Tensione (Europea)				400 v trifase - 50 Hz				
Tension (American) Tensione (Americana)				220 v trifase - 60 Hz				
Impact wrench Avvitatore	DPH 340 M	DPH 340 M AL	DPH 341 M	DPH 341 M AL	DPH 351 M	DPH 351 M AL	DPH 362	DPH 381

 paoli

 paoli

MAIN FEATURES REFERENCES

TILL DYNO 4 (M)

RIFERIMENTI CARATTERISTICHE PRINCIPALI
FINO AL DYNO 4 (M)

TABELLA PRESSIONI COPPIA AVVITAMENTO
TABLEAU PRESSION-COUPLE DE SERRAGE
PRESSURE-TIGHTENING TORQUE TABLE

Pressione Pressure [bar]	Coppia/Couple/Torque [Nm] x 50	
	Dado/Écrou/Boîte M22x1,5	Dado/Écrou/Boîte M25x1,5
60	295	314
70	373	382
80	422	436
90	490	510
100	549	566
110	578	627
120	635	684
130	682	741
140	734	798
150	786	855
160	839	912
170	897	972
180	940	997
190	991	1082
200	1045	1169

Tempo di avvitamento: 5 sec.
Temps de serrage / Tightening time: 5 sec.

Tightening time: 5 seconds
Tempo di avvitamento: 5 secondiBEST FOR
APPLICAZIONIMine and oil field
Miniere e giacimentiConstruction site and shipyard
Cantieri e costruzioni navaliInfrastructures
InfrastruttureCooling fan to prevent overheating
Ventola di raffreddamento per evitare
surriscaldamentoFoldable upper handle
Maniglia superiore pieghevolePressure regulator
Regolatore di pressioneSelector for the inversion of phase:
Allows to use the control unit to
any electrical outletSelettore di Fase:
permette di utilizzare la centralina
su qualsiasi presa di corrente trifaseAdjustable torque up to 200
bar (17000 Nm)
Coppia regolabile fino a 200
bar (17000 Nm)Thermal relay:
protects the electric motor
Relè termico:
protegge il motore termicoBy-pass function to ensure maxi-
mum safety for the operator
Funzione by-pass per garantire
massima sicurezza all'operatoreImpact wrench NOT included
Avvitatore NON incluso

DYNO-M GASOLINE

GAMMA IDRAULICA CON LEVA MECCANICA



DYNO-M GASOLINE micro power pack with 6 Hp gasoline engine – recoil start is designed to guarantee the minimum weight and easy transportability. The machine is available in two configurations of hydraulic power: 20 L/min @ 95 Bar or 12 L/min @ 160 Bar.

Agile and robust DYNO-M GASOLINE is ideal in the utilities maintenance, in general applications with hydraulic tools and in all works where are needed power and transportability. Available with different hydraulic power depending on request.

Il micro power pack DYNO-M GASOLINE con motore a benzina da 6 Hp - l'avviamento è progettato per garantire il minimo peso e la facilità di trasporto. La macchina è disponibile in due configurazioni di potenza idraulica: 20 L/min @ 95 Bar o 12 L/min @ 160 Bar.

Agile e robusto DYNO-M GASOLINE è ideale nella manutenzione delle utenze, in applicazioni generali con utensili idraulici e in tutti i lavori dove sono potenza e trasportabilità necessarie. Disponibile con diverse potenze idrauliche a seconda della richiesta.

Product name	Nome prodotto	DYNO-M GASOLINE
Product code	Codice prodotto	A.03.02.0034
Weight	Peso	42 kg - 92,59 lbs
Overall dimensions	Dimensioni d'ingombro	60x40x43 cm - 24x16x17 in
Max oil flow	Portata massima olio	10 l/min at 185 bar
Pressure	Pressione	95-160 bar
Engine	Motore	Briggs & Stratton 6hp - Gasoline

BEST FOR APPLICAZIONI



Mine and oil field
Miniere e giacimenti



Construction site and shipyard
Cantieri e costruzioni navali



Infrastructures
Infrastrutture

High efficiency oil cooling system
with centrifugal fan

*Sistema di raffreddamento ad alta
efficienza con ventola centrifuga*

Central lifting hook
Gancio di sollevamento centrale

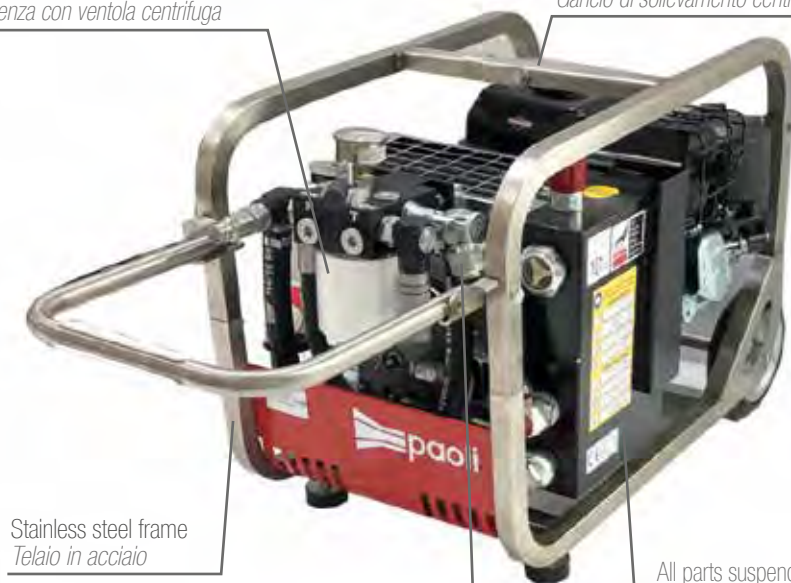

Stainless steel frame
Telaio in acciaio

Quick couplers installed
on impact free swivel fitting
*Attacchi rapidi installati
su raccordi girevoli antiurto*

All parts suspended on
anti-vibration shock mounts
*Tutte le componenti montate
su antivibranti*

CONFIGURE YOUR POWER UNIT CONFIGURA LA TUA CENTRALINA

The electro-hydraulic power units and impact wrenches range with mechanical lever is composed by many different models and customizations to satisfy all requirements.

La gamma di centraline e avvitatori elettro-idraulici Paoli con leva meccanica vanta diversi modelli e personalizzazioni mirati a soddisfare ogni esigenza.

HOW TO ORDER

- 1 select the components **A**
- 2 select the types **B**

COME ORDINARE

- 1 selezionare i componenti **A**
- 2 selezionare le tipologie **B**

POWER UNIT

A COMPONENTS COMPONENTI

B TYPES TIPOLOGIE

Wheels
Ruote

Construction site
Cantiere

Workshop
Officina

Carter
Copertura

With carter
Con copertura

Naked
Senza copertura

Gauge
Manometro

Analogic
Analogico

Digital
Digitale

Heatsink
Dissipatore

With heatsink
Con dissipatore

Without heatsink
Senza dissipatore

POWER UNIT

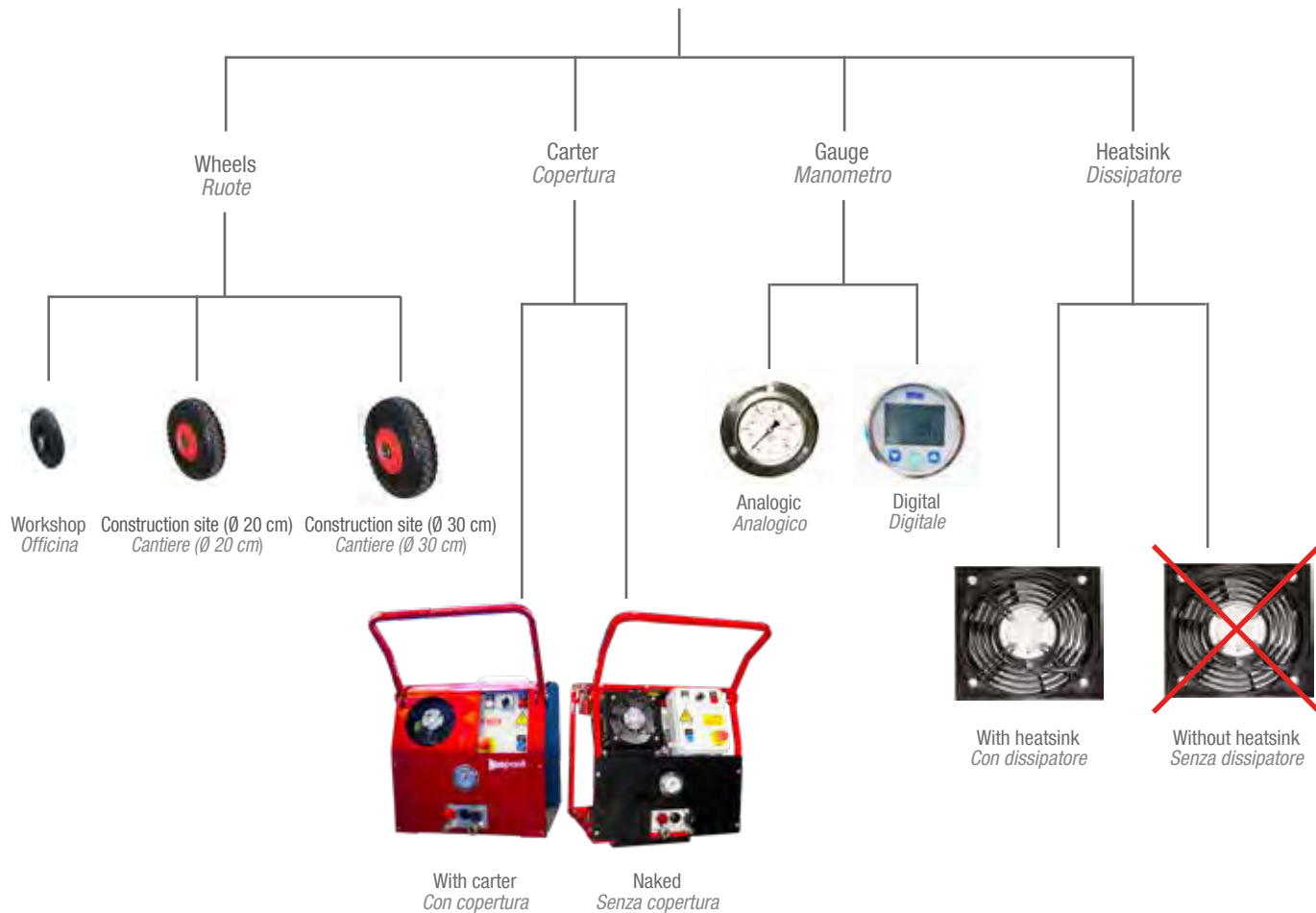

DPLIFT JACKS

The DPLIFT jacks line offers to the customers an easy and safe usage, both for automotive and industrial applications.

The DPLIFT jacks consist of a highly resistant diaphragm and internal telescopic guide.

They are fitted with a limit stop device as well as a safety valve making them absolutely reliable in case of excessive loads.

The DPLIFT jacks are characterized by their high reliability and long life as well as their practicality and elegance. Each jack, made with special prime quality materials, is inspected and tested.

The DPLIFT jacks, available in various models for all stroke and capacity requirements, guarantee perfect holding in every situation.

SOLLEVATORI DPLIFT

La gamma di sollevatori DPLIFT offre ai clienti un utilizzo facile e sicuro sia nel settore automotive che in ambito industriale.

I sollevatori DPLIFT sono costituiti da una membrana ad alta resistenza e da una guida telescopica interna. Sono dotati di un dispositivo d'arresto a fine corsa e di una valvola di sicurezza che li rendono assolutamente affidabili in caso di carichi eccessivi.

I sollevatori DPLIFT sono caratterizzati dalla loro elevata affidabilità e durata nel tempo, nonché per la loro praticità e design. Ogni sollevatore, costruito con materiali di primissima qualità, viene collaudato e testato.













Disponibili in vari modelli adatti a tutte le esigenze di corsa e di portata, i sollevatori DPLIFT garantiscono una perfetta tenuta in ogni situazione.

A close-up, low-angle shot of a hydraulic jack's main cylinder. The cylinder is highly polished, reflecting light in a way that creates bright highlights and deep shadows, emphasizing its metallic texture. A red handle is visible on the left side, partially obscured by the cylinder. The background is dark and out of focus, with some blurred mechanical parts. The overall color palette is dominated by the metallic silver of the cylinder, the red of the handle, and the dark blue/black of the background.

DPLIFT JACKS
SOLLEVATORI DPLIFT









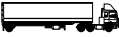

DPLIFT JACKS APPLICATIONS

APPLICAZIONI DEI SOLLEVATORI DPLIFT

	PNEUMATIC JACKS SOLLEVATORI PNEUMATICI			TROLLEY JACKS SOLLEVATORI A CARRELLO								HEAVY VEHICLES MEZZI PESANTI												SPECIAL APPLICATIONS APPLICAZIONI SPECIALI					
	224	264	406	216 S	218 C	40	40 Q	40 QL	80 Q	100 QL	120 Q	200 Q	428 P	430 P	442 P	430 N	430 L	434 N	442 N	624	444 N	1020	636 N	830 R	836 N	270	660 S		
	■																												
	■	■	■	■	■	■	■	■	■																				
	■	■	■	■	■	■	■	■	■	■	■	■																	
	■			■	■	■	■	■	■	■	■	■																	
		■	■	■	■	■	■	■	■	■	■	■																	
																										■	■		
												■	■	■		■	■	■	■	■	■	■		■	■	■			
					■					■	■	■										■		■	■	■		■	
											■	■			■							■		■	■	■		■	
					■				■	■	■	■			■							■		■	■	■		■	
											■	■	■	■	■	■	■	■	■	■	■	■		■	■	■		■	
												■	■	■	■	■	■	■	■	■	■	■		■	■	■		■	

APPLICAZIONI DEI SOLLEVATORI DPLIFT

DPLIFT JACKS APPLICATIONS

	PNEUMATIC JACKS SOLLEVATORI PNEUMATICI			TROLLEY JACKS SOLLEVATORI A CARRELLO								HEAVY VEHICLES MEZZI PESANTI										SPECIAL APPLICATIONS APPLICAZIONI SPECIALI						
	224	264	406	216 S	218 C	40	40 Q	40 QL	80 Q	100 QL	120 Q	200 Q	428 P	430 P	442 P	430 N	430 L	434 N	442 N	624	444 N	1020	636 N	830 R	836 N	270	660 S	
												■	■	■	■	■	■	■	■		■		■	■	■		■	
													■	■	■	■	■	■	■		■		■	■	■		■	
													■	■	■	■	■	■	■		■		■	■	■		■	
													■	■	■	■	■	■	■		■		■	■	■		■	
															■					■		■		■	■	■	■	■
				■	■					■	■	■	■			■				■						■	■	
															■					■		■		■	■	■	■	
																					■		■	■	■	■	■	
																					■		■	■	■	■	■	
																					■		■	■	■	■	■	
												■		■		■				■	■	■	■					

PNEUMATIC JACKS SOLLEVATORI PNEUMATICI

Pneumatically controlled jacks consisting of a highly resistant diaphragm and internal telescopic guide. These jacks are fitted with a limit stop device as well as a safety valve making them absolutely reliable in the case of excessive loads.

Silent, simple and lightweighted, they are ideal for tyre repairers and bodywork shops as they can also be used on column lifts.

This technology is specifically created and developed for the automotive sector.

Sollevatori pneumatici costituiti da una membrana ad alta resistenza e da una guida telescopica interna. Sono dotati di un dispositivo d'arresto a fine corsa e di una valvola di sicurezza che li rendono assolutamente affidabili in caso di carichi eccessivi.

Silenziosi, semplici e leggeri, rappresentano il prodotto ideale per gommisti e carrozzieri in funzione della possibilità di utilizzo anche sui ponti sollevatori.

Progettati e sviluppati per il settore automobilistico.

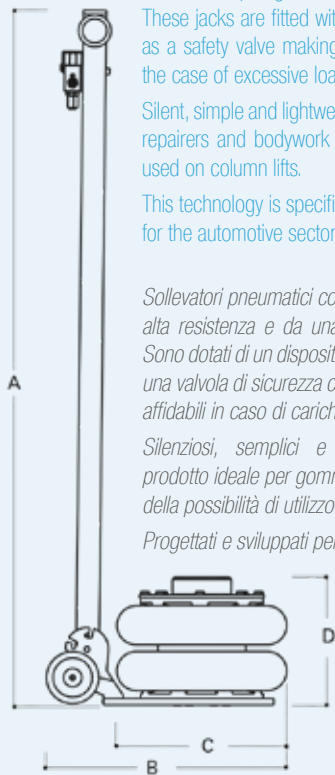

DPLIFT 224

Product code <i>Codice prodotto</i>	B.37.05.01.0024
Capacity <i>Portata</i>	2.2 ton 2 t
Net weight <i>Peso</i>	36 lb 16.5 kg
Working pressure <i>Pressione utilizzo</i>	116/145 psi 8/10 bar
Pistons <i>Sfili</i>	2
Pistons stroke <i>Corsa sfili</i>	4.5/4.5 in 114/114 mm
B	19.37 in 492 mm
C	9.84 in 250 mm
D	4.41-13.39 in 112-340 mm

DPLIFT 264

Product code <i>Codice prodotto</i>	B.37.05.01.0001
Capacity <i>Portata</i>	2.2 ton 2 t
Net weight <i>Peso</i>	31 lb 14 kg
Working pressure <i>Pressione utilizzo</i>	116/145 psi 8/10 bar
Pistons <i>Sfili</i>	2
Pistons stroke <i>Corsa sfili</i>	3.8/3.8 in 97/97 mm
B	16.34 in 415 mm
C	9.84 in 250 mm
D	5.2-12.83 in 132-326 mm



DPLIFT 406

Product code
Codice prodotto B.37.05.01.0029

Capacity
Portata 2.2 ton
2 t

Net weight
Peso 37 lb
17 Kg

Working pressure
Pressione utilizzo 116/145 psi
8/10 bar

Pistons
Sfilii 3

Pistons stroke
Corsa sfilii 3.7 - 3.7 - 3.7 in
95 - 95 - 95 mm

B 16.34 in
415 mm

C 9.84 in
250 mm

D 8.07-19.29 in
205-490 mm



AIR HYDRAULIC TROLLEY JACKS SOLLEVATORI OLEOPNEUMATICI A CARRELLO

Air hydraulic trolley jacks, practical and easy to handle.

These jacks are equipped with an arm that moves back automatically. The two descent valves guarantee perfect holding in all situations and controlled speed under load.

Thanks to minimum height, maximum height and capacity these jacks are particularly versatile.

They are ideal for workshops, tyre repairers and bodywork shops.

Sollevatori oleopneumatici a carrello, pratici e maneggevoli.

Questi sollevatori sono dotati di rientro automatico del braccio. Le due valvole di discesa garantiscono una tenuta perfetta in ogni situazione e una velocità controllata sotto carico.

La combinazione tra altezza minima, altezza massima e portata rendono questi sollevatori particolarmente versatili.

Rappresentano il prodotto ideale per officine, gommisti e carrozzerie.



DPLIFT 216 S

Product code
Codice prodotto B.37.05.01.0026

Capacity
Portata 3,3 ton
3 t

Net weight
Peso 143 lb - 65 Kg

Working pressure
Pressione utilizzo 102/145 psi
7/10 bar

Max stroke
Corsa max. 23.1 in
588 mm

A 56.53 in - 1436 mm

C 42.91 in - 1090 mm

D 3.5 in - 88 mm



C: Trolley model
C: Modello carrellato

DPLIFT 218 C

Product code
Codice prodotto B.37.05.01.0002

Capacity
Portata 5,5 ton
5 t

Net weight
Peso 165 lb - 75 kg

Working pressure
Pressione utilizzo 116/145 psi
8/10 bar

Max stroke
Corsa max. 16.1 in
410 mm

A 54.72 in - 1390 mm

B 51.57 in - 1310 mm

C 35.82 in - 910 mm

D 3.74 in - 95 mm



C: Trolley model
C: Modello carrellato

MANUAL HYDRAULIC TROLLEY JACKS SOLLEVATORI IDRAULICI MANUALI A CARRELLO

The pump is manually operated by handle movement. The pedal control on the 40 Q model is used for a quick approach.

These jacks are particularly suitable for cars, campers and vans.

Lightweight and easy to handle, ideal for tyre repairers, workshops and bodywork shops.

L'azionamento manuale della pompa avviene attraverso il movimento del manico. Sul modello 40 Q è presente inoltre l'avvicinamento rapido a pedale.

Questi sollevatori sono indicati particolarmente per autovetture, camper e furgoni. Leggeri e maneggevoli, ideali per gommisti, officine e carrozzerie.

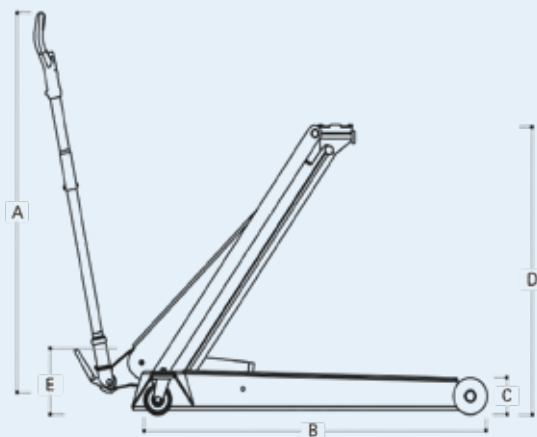

DPLIFT 40

Product code <i>Codice prodotto</i>	B.37.05.01.0010
Capacity <i>Portata</i>	2.2 ton 2 t
Net weight <i>Peso</i>	68 lb - 31 Kg
Max stroke <i>Corsa max.</i>	16.3 in 415 mm
A	37.40 in 950 mm
B	25.98 in 660 mm
C	3.15 in 80 mm
D	16.49 in 495 mm
E	6.30 in 160 mm



DPLIFT 40 Q

Product code <i>Codice prodotto</i>	B.37.05.01.0025
Capacity <i>Portata</i>	2.2 ton 2 t
Net weight <i>Peso</i>	68 lb - 31 Kg
Max stroke <i>Corsa max.</i>	16.3 in 415 mm
A	37.40 in 950 mm
B	25.98 in 660 mm
C	3.15 in 80 mm
D	16.49 in 495 mm
E	6.30 in 160 mm



Q: With pedal control
for a quick approach

Q: Con avvicinamento rapido
a pedale



DPLIFT 40 QL

Product code <i>Codice prodotto</i>	B.37.05.01.0059
Capacity <i>Portata</i>	2.2 ton - 2 t
Net weight <i>Peso</i>	108 lb - 49 kg
Max stroke <i>Corsa max.</i>	28.1 in 715 mm
A	37.40 in 950 mm
B	37.40 in 950 mm
C	3.15 in 80 mm
D	31.3 in 795 mm
E	8.66 in 220 mm



QL: Long model with pedal control
for a quick approach

QL: Modello lungo con avvicinamento
rapido a pedale

DPLIFT 80 Q

Product code <i>Codice prodotto</i>	B.37.05.01.0017
Capacity <i>Portata</i>	4.4 ton - 4 t
Net weight <i>Peso</i>	194 lb - 88 kg
Max stroke <i>Corsa max.</i>	18.3 in 465 mm
A	37.40 in 950 mm
B	31.5 in 800 mm
C	5.51 in 140 mm
D	23.62 in 600 mm
E	9.45 in 240 mm



Q: With pedal control
for a quick approach

Q: Con avvicinamento rapido
a pedale

DPLIFT 100 QL

Product code <i>Codice prodotto</i>	B.37.05.01.0034
Capacity <i>Portata</i>	5.5 ton - 5 t
Net weight <i>Peso</i>	375 lb - 170 kg
Max stroke <i>Corsa max.</i>	33 in 835 mm
A	47.24 in 1200 mm
B	50.8 in 1290 mm
C	5.5 in 140 mm
D	38.3 in 975 mm
E	10.4 in 265 mm



QL: Long model with pedal control for a quick approach
QL: Modello lungo con avvicinamento rapido a pedale

DPLIFT 120 Q

Product code <i>Codice prodotto</i>	B.37.05.01.0058
Capacity <i>Portata</i>	6.6 ton - 6 t
Net weight <i>Peso</i>	209 lb - 95 kg
Max stroke <i>Corsa max.</i>	18 in 460 mm
A	47.24 in 1200 mm
B	31.5 in 800 mm
C	5.5 in 140 mm
D	23.6 in 600 mm
E	9.45 in 240 mm



Q: With pedal control for a quick approach
Q: Con avvicinamento rapido a pedale

DPLIFT 200 Q

Product code <i>Codice prodotto</i>	B.37.05.01.0057
Capacity <i>Portata</i>	11 ton - 10 t
Net weight <i>Peso</i>	260 lb - 118 kg
Max stroke <i>Corsa max.</i>	17.1 in 435 mm
A	47.24 in 1200 mm
B	31.69 in 805 mm
C	5.91 in 150 mm
D	23.03 in 585 mm
E	10.24 in 260 mm



Q: With pedal control for a quick approach
Q: Con avvicinamento rapido a pedale

HEAVY VEHICLES - PORTABLE MEZZI PESANTI - PORTATILI

PORTABLE AIR HYDRAULIC JACKS

Jacks for heavy vehicles, lightweighted and easy to handle, with removable handle. All the reliability and practicality of DPLIFT jacks in a more compact version.

Ideal for keeping on board the vehicle and for road assistance.

SOLLEVATORI OLEOPNEUMATICI PORTATILI

Sollevatori per mezzi pesanti, leggeri e maneggevoli, con manico smontabile. Tutta l'efficacia e la praticità dei sollevatori DPLIFT in una versione più compatta.

Ideali da tenere a bordo del mezzo e per chi svolge assistenza su strada.

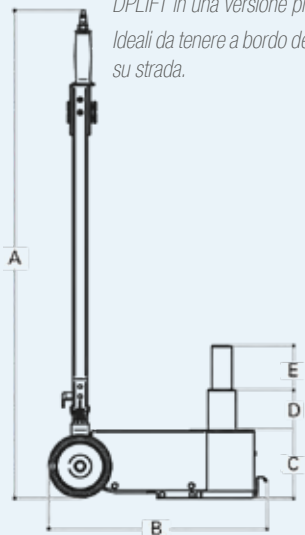

Trolley box included for the model DPLIFT 428 P

Cassa trolley inclusa nel modello DPLIFT 428 P

DPLIFT 428 P

Product code <i>Codice prodotto</i>	B.37.05.01.0012
Capacity <i>Portata</i>	22/11 ton - 20/10 t
Net weight <i>Peso</i>	33 lb - 15 Kg
Working pressure <i>Pressione utilizzo</i>	116/145 psi 8/10 bar
Max stroke <i>Corsa max.</i>	6.5 in - 166 mm
Pistons <i>Sfilii</i>	2
A	13.94 - 41.42 in 354 - 1052 mm
B	14.96 in - 380 mm
C	5.51 in - 140 mm
D	3.15 in - 80 mm
E	3.39 in - 86 mm

DPLIFT 430 P

Product code <i>Codice prodotto</i>	B.37.05.01.0004
Capacity <i>Portata</i>	44.1/22 ton - 40/20 t
Net weight <i>Peso</i>	77 lb - 35 kg
Working pressure <i>Pressione utilizzo</i>	116/145 psi 8/10 bar
Max stroke <i>Corsa max.</i>	5.9 in - 150 mm
Pistons <i>Sfilii</i>	2
A	43.31 in - 1100 mm
B	16.69 in - 500 mm
C	5.91 in - 150 mm
D	2.83 in - 72 mm
E	3.07 in - 78 mm



P: Portable model
P: Modello portatile



P: Portable model
P: Modello portatile

DPLIFT 442 P

Product code B.37.05.01.0056
Codice prodotto

Capacity 44.1/22 ton
Portata 40/20 t

Net weight *Peso* 93 lb - 42 kg

Working pressure 116/145 psi
Pressione utilizzo 8/10 bar

Max stroke 9.8 in
Corsa max. 250 mm

Pistons *Sfili* 2

A 43.70 in
1110 mm

B 19.3 in
490 mm

C 8.62 in
219 mm

D 4.92 in
125 mm

E 4.92 in
125 mm



HEAVY VEHICLES - COMPACT MEZZI PESANTI - COMPATTI

HEAVY VEHICLES RANGE

Air-hydraulic jacks designed especially to meet the specific needs of heavy vehicles and for all the jobs where a compact size and power are a must.

The heavy vehicles range is composed by jacks capable of meeting all requirements of stroke and capacity. The pistons move back automatically.

These air hydraulic jacks are aimed mainly to trucks, semi-articulated trucks, trailers and tractors.

GAMMA PER MEZZI PESANTI

Sollevatori oleopneumatici progettati in modo particolare per soddisfare le esigenze specifiche dei mezzi pesanti e per tutte le operazioni dove la compattezza e la potenza sono un'esigenza.

La gamma per mezzi pesanti è costituita da sollevatori per tutte le esigenze di corsa e portata. I pistoni sono a rientro automatico.

Questi sollevatori oleopneumatici sono particolarmente indicati per autocarri, autoarticolati, rimorchi e motrici.



DPLIFT 430 N

Product code
Codice prodotto B.37.05.01.0005

Capacity
Portata 44.1/22 ton
40/20 t

Net weight *Peso* 86 lb - 39 kg

Working pressure
Pressione utilizzo 116/145 psi
8/10 bar

Max stroke
Corsa max. 5.9 in
150 mm

Pistons *Sfilii* 2

A 55.12 in
1400 mm

B 20.67 in
525 mm

C 5.98 in
152 mm

D 5.79 in
147 mm

E 2.80 in
71 mm

N: Standard model
N: Modello standard

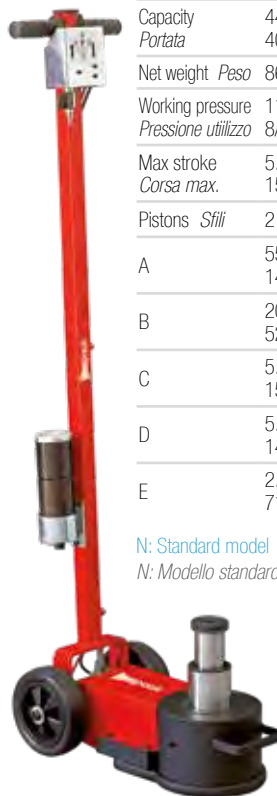

BEST SELLER!

DPLIFT 434 N

Product code
Codice prodotto B.37.05.01.0022

Capacity
Portata 44.1/22 ton
40/20 t

Net weight *Peso* 90 lb - 41 kg

Working pressure
Pressione utilizzo 116/145 psi
8/10 bar

Max stroke
Corsa max. 6.7 in
171 mm

Pistons *Sfilii* 2

A 55.12 in
1400 mm

B 56.61 in
1311 mm

C 5.90 in
150 mm

D 12.80 in
325 mm

E 6.69 in
174 mm

N: Standard model
N: Modello standard

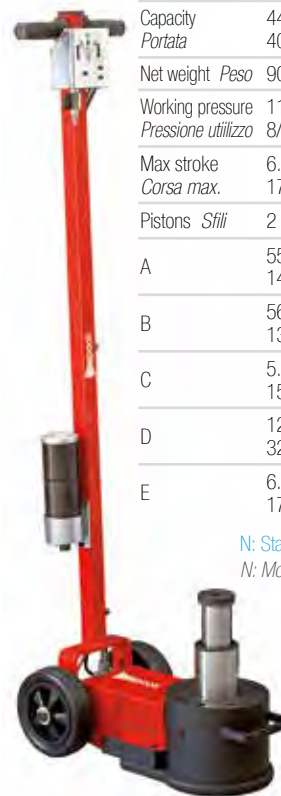

DPLIFT 442 N



Product code <i>Codice prodotto</i>	B.37.05.01.0037
Capacity <i>Portata</i>	44.1/22 ton 40/20 t
Net weight <i>Peso</i>	101 lb - 46 kg
Working pressure <i>Pressione utilizzo</i>	116/145 psi 8/10 bar
Max stroke <i>Corsa max.</i>	9.8 in 250 mm
Pistons <i>Sfilii</i>	2
A	55.12 in 1400 mm
B	20.67 in 525 mm
C	8.62 in 219 mm
D	9.84 in 250 mm
E	4.92 in 125 mm

N: Standard model
N: Modello standard

DPLIFT 430 L



Product code <i>Codice prodotto</i>	B.37.05.01.0015
Capacity <i>Portata</i>	44.1/22 ton 40/20 t
Net weight <i>Peso</i>	86 lb - 39 kg
Working pressure <i>Pressione utilizzo</i>	116/145 psi 8/10 bar
Max stroke <i>Corsa max.</i>	5.9 in 150 mm
Pistons <i>Sfilii</i>	2
A	55.31 in 1405 mm
B	27.56 in 700 mm
C	6.10 in 155 mm
D	2.76 in 70 mm
E	3.03 in 77 mm

L: Long model
L: Modello lungo

DPLIFT 630 L



Product code <i>Codice prodotto</i>	B.37.05.01.0006
Capacity <i>Portata</i>	66.1/33.1/19.8 ton 60/30/18 t
Net weight <i>Peso</i>	101 lb - 46 kg
Working pressure <i>Pressione utilizzo</i>	116/145 psi 8/10 bar
Pistons <i>Sfilii</i>	3
Pistons stroke <i>Corsa sfilii</i>	2.5/2.2/2.6 in 63/56/66 mm
A	55.1 in - 1400 mm
B	52 in - 1320 mm
C	28.7 in - 730 mm
D	9.84 in - 250 mm
E	5.91 in - 150 mm
F	7.28 in - 185 mm

L: Long model
L: Modello lungo

HEAVY VEHICLES – STANDARD SIZE

MEZZI PESANTI – DIMENSIONE STANDARD

Air hydraulic jacks for heavy vehicles, practical and effective.

The pistons move back automatically; the two descent valves guarantee perfect holding in all situations and controlled speed under load. Ideal for workshops, tyre repairers and bodywork shops.

Sollevatori oleopneumatici per mezzi pesanti, pratici ed efficaci

Rientro automatico dei pistoni; le due valvole di discesa garantiscono una tenuta perfetta in ogni situazione e una velocità controllata sotto carico. Ideali per officine, gommisti e carrozzerie.

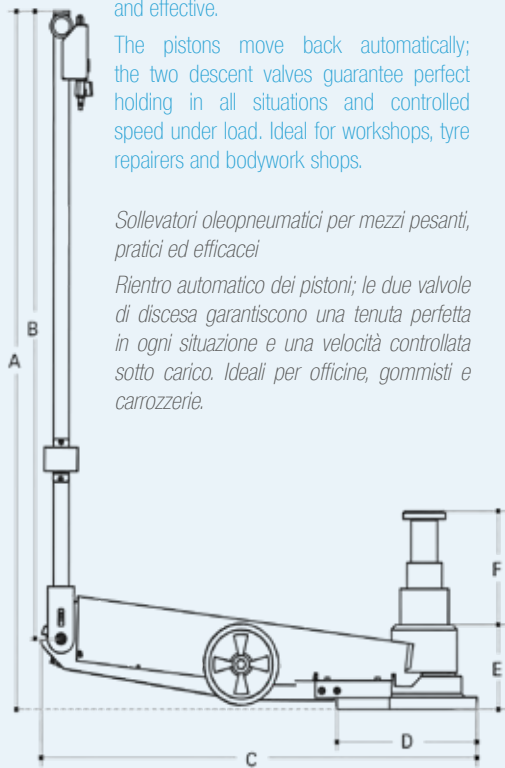

DPLIFT 444 N

Product code B.37.05.01.0043
Codice prodotto

Capacity 66.1/33.1 ton
Portata 60/30 t

Net weight *Peso* 157 lb - 71 Kg

Working pressure 116/145 psi
Pressione utilizzo 8/10 bar

Pistons *Sfilii* 2

Pistons stroke 4.3 - 4.7 in
Corsa sfilii 110 - 120 mm

A 57.28 in - 1455 mm

B 51.7 in - 1310 mm

C 39.4 in - 1000 mm

D 12.6 in - 320 mm

E 8.7 in - 221 mm

F 8.7 in - 226 mm

N: Standard model

N: Modello standard



DPLIFT 636 N

Product code B.37.05.01.0021
Codice prodotto

Capacity 66.1/33.1/19.8 ton
Portata 60/30/18 t

Net weight *Peso* 152 lb - 69 Kg

Working pressure 116/145 psi
Pressione utilizzo 8/10 bar

Pistons *Sfilii* 3

Pistons stroke 3/2.8/3.6 in
Corsa sfilii 75/72/91 mm

A 57.28 in - 1455 mm

B 51.7 in - 1310 mm

C 39.4 in - 1000 mm

D 12.6 in - 320 mm

E 7.1 in - 180.5 mm

F 9.24 in - 235 mm

N: Standard model

N: Modello standard



HEAVY VEHICLES MEZZI PESANTI

Air hydraulic jacks for heavy vehicles, practical and effective.

The pistons move back automatically; the two descent valves guarantee perfect holding in all situations and controlled speed under load. Ideal for workshops, tyre repairers and bodywork shops.

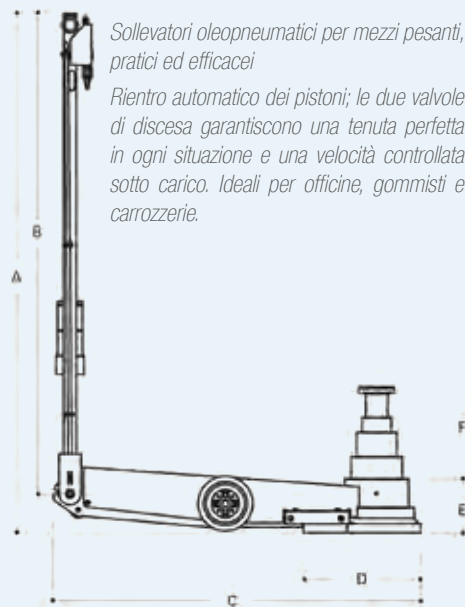

Sollevatori oleopneumatici per mezzi pesanti, pratici ed efficaci

Rientro automatico dei pistoni; le due valvole di discesa garantiscono una tenuta perfetta in ogni situazione e una velocità controllata sotto carico. Ideali per officine, gommisti e carrozzerie.

DPLIFT 830 R

Product code
Codice prodotto B.37.05.01.0028

Capacity
Portata 77/47/25/14 ton
70/43/23/13 t

Net weight *Peso* 163 lb - 74 kg

Working pressure
Pressione utilizzo 116/145 psi
8/10 bar

Pistons *Sfili* 4

Pistons stroke
Corsa sfili 2.4/2.7/2.2/2.6 in
60/68/56/66 mm

A 54.6 in - 1390 mm

B 51.6 in - 1310 mm

C 39.4 in - 1000 mm

D 12.6 in - 320 mm

E 5.9 in - 150 mm

F 9.8 in - 250 mm

R: Lowered model
R: Modello ribassato



DPLIFT 836 N

Product code
Codice prodotto B.37.05.01.0016

Capacity
Portata 88/55/28/17 ton
80/50/25/15 t

Net weight *Peso* 170 lb - 77 kg

Working pressure
Pressione utilizzo 116/145 psi
8/10 bar

Pistons *Sfili* 4

Pistons stroke
Corsa sfili 2.5/2.8/2.8/3.6 in
65/72/72/91 mm

A 55.9 in - 1420 mm

B 51.6 in - 1310 mm

C 39.4 in - 1000 mm

D 12.6 in - 320 mm

E 7.1 in - 180 mm

F 11.8 in - 300 mm

N: Standard model
N: Modello standard



HEAVY VEHICLES - EXTRA LOW MEZZI PESANTI - EXTRA BASSI

Air-hydraulic jacks with pistons moving back automatically.

Specifically designed for lifting buses and all vehicles with low profile axles.

Sollevatori Oleopneumatici con rientro automatico dei pistoni.

Studiati appositamente per il sollevamento degli autobus e di quei mezzi i cui assali risultano essere molto bassi.

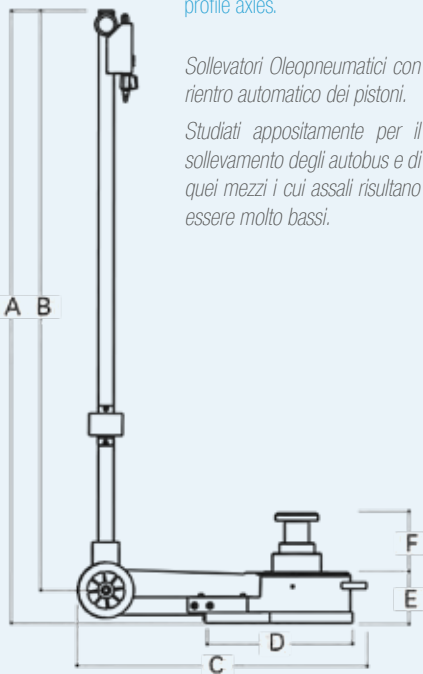

DPLIFT 624

Product code <i>Codice prodotto</i>	B.37.05.01.0008
Capacity <i>Portata</i>	66.1/33.1/16.5 ton 60/30/15 t
Net weight <i>Peso</i>	110 lb - 50 kg
Working pressure <i>Pressione utilizzo</i>	116/145 psi 8/10 bar
Pistons <i>Sfilii</i>	3
Pistons stroke <i>Corsa sfilii</i>	1.6/1.8/2 in 40/45/50 mm
A	54.53 in - 1380 mm
B	51.57 in - 1310 mm
C	25.98 in - 660 mm
D	12.99 in - 330 mm
E	4.74 in - 120 mm
F	5.31 in - 135 mm

Extra low model
Modello extra basso

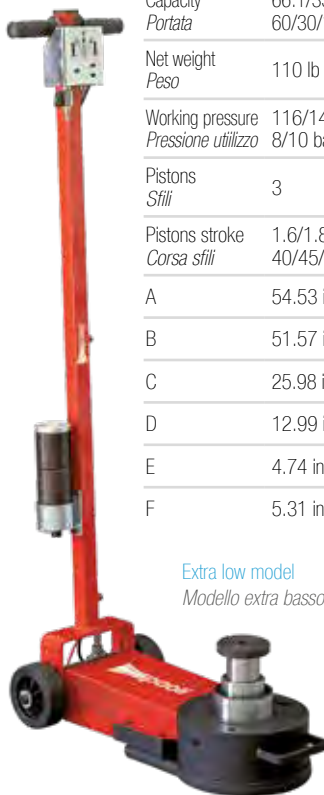

DPLIFT 1020

Product code <i>Codice prodotto</i>	B.37.05.01.0023
Capacity <i>Portata</i>	49/35/24/15/9 ton 44/32/22/14/8 t
Net weight <i>Peso</i>	139 lb - 63 Kg
Working pressure <i>Pressione utilizzo</i>	116/145 psi 8/10 bar
Pistons <i>Sfilii</i>	5
Pistons stroke <i>Corsa sfilii</i>	1.3/1.3/1.3/1.3/1.3 in 32/32/32/32/32 mm
A	54.53 in - 1385 mm
B	51.57 in - 1310 mm
C	39.37 in - 1000 mm
D	12.60 in - 320 mm
E	3.94 in - 100 mm
F	6.3 in - 160 mm

Extra low model
Modello extra basso



SPECIAL APPLICATIONS APPLICAZIONI SPECIALI

Air hydraulic jacks for heavy vehicles, practical and effective.

The pistons move back automatically; the two descent valves guarantee perfect holding in all situations and controlled speed under load.

DPLIFT 270: ideal for agricultural and public works vehicles. Fitted with roll-over protection plate.

DPLIFT 660 S: specific for lifting the vehicle from the chassis and for all operations where maximum stroke and capacity are required.

Sollevatori oleopneumatici per mezzi pesanti, pratici ed efficaci.

Rientro automatico dei pistoni; le due valvole di discesa garantiscono una tenuta perfetta in ogni situazione e una velocità controllata sotto carico.

DPLIFT 270: ideale per mezzi agricoli e macchine operatrici. Dotato di piastra antiribaltamento.

DPLIFT 660 S: specifico per il sollevamento del mezzo dal telaio e per tutte le operazioni dove occorrono molta corsa e molta portata.



DPLIFT 270

Product code <i>Codice prodotto</i>	B.37.05.01.0027
Capacity <i>Portata</i>	30 t - 33.1 ton
Net weight <i>Peso</i>	126 lb - 57 Kg
Working pressure <i>Pressione utilizzo</i>	116/145 psi 8/10 bar
Max stroke <i>Corsa max.</i>	9.1 in - 230 mm
Pistons <i>Sfilii</i>	1
A	55.71 in - 1415 mm
B	51.77 in - 1315 mm
C	28.54 in - 725 mm
D	13.8 in - 350 mm
E	9.1 in - 230 mm



DPLIFT 660 S

Product code <i>Codice prodotto</i>	B.37.05.01.0052
Capacity <i>Portata</i>	80/50/25 t 88.2/55.1/27.6 ton
Net weight <i>Peso</i>	227 lb - 103 kg
Working pressure <i>Pressione utilizzo</i>	116-174 psi 8-12 bar
Max stroke <i>Corsa max.</i>	20.7 in - 525 mm
Pistons <i>Sfilii</i>	3
Pistons stroke <i>Corsa sfilii</i>	6.5/6.7/7.5 in 165/170/190 mm
A	32.9 in - 835 mm
C	43.9 in - 1115 mm
D	12.2 in - 310 mm
E	20.67 in - 525 mm



S: Speed model
S: Modello più veloce

NEW PUMP EVEN MORE POWERFUL
NUOVA POMPA ANCORA PIÙ PERFORMANTE

 paoli

DPLIFT JACKS

MINING AND INDUSTRIAL APPLICATIONS

The mining and industrial applications DPLIFT JACKS are hydro-pneumatically operated and equipped with a dual descent valve and automatic piston return.

For excellent handling during use and transport, they have: foulding handle, pneumatic tyres for any surface, special hook for transport.

SOLLEVATORI DPLIFT

MINIERA E APPLICAZIONI INDUSTRIALI

I sollevatori DPLIFT da miniera e per applicazioni industriali sono oleopneumatici, con doppia valvola di discesa e con rientro automatico dei pistoni.

Per un'eccellente manovrabilità durante l'utilizzo e il trasporto, dispongono di: manico pieghevole, ruote pneumatiche per qualsiasi superficie, ganci speciali per il trasporto.

A red hydraulic jack is shown supporting a heavy metal beam. The jack has a silver-colored piston rod and a black handle. The background shows a pile of rocks and a concrete structure.

DPLIFT JACKS SOLLEVATORI DPLIFT

**MINING AND INDUSTRIAL APPLICATIONS
MINIERA E APPLICAZIONI INDUSTRIALI**

MINING AND INDUSTRIAL APPLICATIONS MINIERA E APPLICAZIONI INDUSTRIALI

The mining and industrial applications jacks are hydro-pneumatically operated and equipped with a dual descent valve and automatic piston return.

For excellent handling during use and transport, they have: folding handle, pneumatic tyres for any surface, special hook for transport.

I sollevatori da miniera e per applicazioni industriali sono oleopneumatici, con doppia valvola di discesa e con rientro automatico dei pistoni.

Per un'eccellente manovrabilità durante l'utilizzo e il trasporto, dispongono di: manico pieghevole, ruote pneumatiche per qualsiasi superficie, ganci speciali per il trasporto.

APPLICATIONS APPLICAZIONI

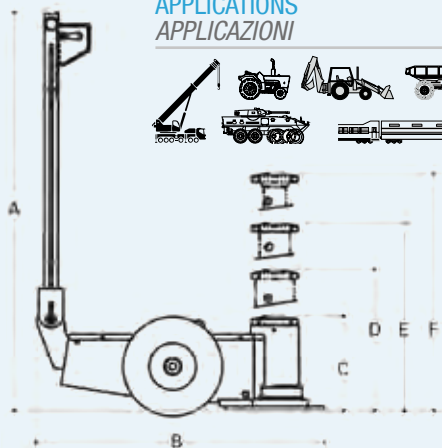

DPLIFT 60/22

Product code <i>Codice prodotto</i>	B.37.05.01.0018
Capacity <i>Portata</i>	66.1/33.1 ton 60/30 t
Net weight <i>Peso</i>	207 lbs - 94 Kg
Working pressure <i>Pressione utilizzato</i>	145-174 psi 10-12 bar
Max stroke <i>Corsa max.</i>	13.3 in 337 mm
Pistons <i>Sfilii</i>	2
Pistons stroke <i>Corsa sfilii</i>	4.3 - 8.9 in 110 - 227 mm
A	54.5 in - 1385 mm
B	37 in - 940 mm
C	8.7 in - 220 mm
D	13 in - 330 mm
E	17.6 in - 447 mm



DPLIFT 80/31

Product code <i>Codice prodotto</i>	B.37.05.01.0019
Capacity <i>Portata</i>	88.2/55.1/27.6 ton 80/50/25 t
Net weight <i>Peso</i>	304 lbs - 138 Kg
Working pressure <i>Pressione utilizzato</i>	145-174 psi 10/12 bar
Max stroke <i>Corsa max.</i>	20.4 in 518 mm
Pistons <i>Sfilii</i>	3
Pistons stroke <i>Corsa sfilii</i>	6.6-6.7-7.1 in 167-171-180 mm
A	56.7 in - 1440 mm
B	40.9 in - 1040 mm
C	13.4 in - 341 mm
D	20 in - 508 mm
E	26.7 in - 679 mm
F	13.4 in - 341 mm



MINING AND INDUSTRIAL APPLICATIONS MINIERA E APPLICAZIONI INDUSTRIALI

ACCESSORIES ACCESSORI

EXTENSIONS KITS KIT PROLUNGHE



B.37.06.01.0012



B.37.06.01.0013

Code	B.37.06.01.0012	B.37.06.01.0013
Codice		

For models	DPLIFT 80/31	DPLIFT 100/72
Per i modelli	DPLIFT 80/42	DPLIFT 150/90

SAFETY DEVICE SYSTEM KIT KIT BLOCCHI DI SICUREZZA



B.37.06.01.0010



B.37.06.01.0011

Code	B.37.06.01.0010	B.37.06.01.0011
Codice		

For models	DPLIFT 80/31	DPLIFT 100/72
Per i modelli	DPLIFT 80/42	DPLIFT 150/90

DPLIFT 80/42

Product code <i>Codice prodotto</i>	B.37.05.01.0014
Capacity <i>Portata</i>	88.2/55.1 ton 80/50 t
Net weight <i>Peso</i>	320 lbs - 145 Kg
Working pressure <i>Pressione utilizzo</i>	145-174 psi 10-12 bar
Max stroke <i>Corsa max.</i>	18.1 in 461 mm
Pistons <i>Sfili</i>	2
Pistons stroke <i>Corsa sfili</i>	9.4-8.7 in 239-222 mm
A	58.1 in - 1475 mm
B	40.9 in - 1040 mm
C	16.5 in - 418 mm
D	25.9 in - 658 mm
E	34.6 in - 880 mm



DPLIFT 100/40

Product code <i>Codice prodotto</i>	B.37.05.01.0054
Capacity <i>Portata</i>	110.2 ton 100 t
Net weight <i>Peso</i>	419 lbs - 190 Kg
Working pressure <i>Pressione utilizzo</i>	145-174 psi 10/12 bar
Max stroke <i>Corsa max.</i>	8 in 202 mm
Pistons <i>Sfili</i>	1
Pistons stroke <i>Corsa sfili</i>	8 in 202 mm
A	58 in - 1475 mm
B	40.9 in - 1040 mm
C	15.7 in - 398 mm
D	23.6 in - 600 mm





DPLIFT 100/72

Product code <i>Codice prodotto</i>	B.37.05.01.0020
Capacity <i>Portata</i>	110.2 ton 100 t
Net weight <i>Peso</i>	714 lbs - 324 Kg
Working pressure <i>Pressione utilizzo</i>	145-174 psi 10-12 bar
Max stroke <i>Corsa max.</i>	17.5 in - 445 mm
Pistons <i>Sfilii</i>	1
A	68.7 in - 1746 mm
B	47.6 in - 1210 mm
C	28.5 in - 725 mm
D	17.5 in - 445 mm



DPLIFT 150/72

Capacity <i>Portata</i>	165.3 ton 150 t
Net weight <i>Peso</i>	809 lbs - 367 kg
Working pressure <i>Pressione utilizzo</i>	145-174 psi 10-12 bar
Max stroke <i>Corsa max.</i>	14.6 in - 372 mm
Pistons <i>Sfilii</i>	1
A	69.2 in - 1758 mm
B	48.1 in - 1222 mm
C	28.3 in - 720 mm
D	42.9 in - 1092 mm



DPLIFT 150/90

Product code <i>Codice prodotto</i>	B.37.05.01.0013
Capacity <i>Portata</i>	165.3 ton 150 t
Net weight <i>Peso</i>	858 lbs - 389 kg
Working pressure <i>Pressione utilizzo</i>	145-174 psi 10-12 bar
Max stroke <i>Corsa max.</i>	21.8 in - 554 mm
Pistons <i>Sfilii</i>	1
A	78.6 in - 1742 mm
B	49 in - 1245 mm
C	35.5 in - 901 mm
D	21.8 in - 554 mm



DPLIFT 200/65

Product code <i>Codice prodotto</i>	B.37.05.01.0068
Capacity <i>Portata</i>	220.5 ton 200 t
Net weight <i>Peso</i>	849 lbs - 385 kg
Working pressure <i>Pressione utilizzo</i>	145-174 psi 10-12 bar
Max stroke <i>Corsa max.</i>	13.8 in - 350 mm
Pistons <i>Sfilii</i>	1
A	69.2 in - 1757 mm
B	49.3 in - 1253 mm
C	25.5 in - 650 mm
D	39.3 in - 1000 mm



DPLIFT 200/90

Product code <i>Codice prodotto</i>	B.37.05.01.0067
Capacity <i>Portata</i>	220.5 ton 200 t
Net weight <i>Peso</i>	992 lbs - 450 kg
Working pressure <i>Pressione utilizzo</i>	145-174 psi 10-12 bar
Max stroke <i>Corsa max.</i>	21.7 in - 550 mm
Pistons <i>Sfilii</i>	1
A	69.2 in - 1757 mm
B	49.3 in - 1253 mm
C	35.4 in - 900 mm
D	57 in - 1450 mm



1 PISTON PIT JACKS

SOLLEVATORI DA FOSSA MONOSFILO

The pit jacks range is aimed at the heavy vehicles sector and is composed by many different models and customizations to satisfy all requirements.

We use capacities of 15 to 20 tons which can be matched with standard jacking beams of 3 different heights and 2 different lengths. In addition, you can choose the rollers type.

La gamma di sollevatori da fossa si rivolge principalmente al settore veicoli pesanti e vanta diversi modelli e personalizzazioni mirati a soddisfare ogni esigenza.

Abbiamo a disposizione portate da 15 a 20 tonnellate a cui affianchiamo traverse standard di 3 altezze e 2 larghezze differenti. Inoltre, è possibile scegliere la tipologia dei rulli.

HOW TO ORDER

- 1 select the capacity **A**
- 2 select the beam height **B**
- 3 select the beam length **C**
- 4 select the rollers type **D**

COME ORDINARE

- 1 selezionare la portata **A**
- 2 selezionare l'altezza della traversa **B**
- 3 selezionare la larghezza della traversa **C**
- 4 selezionare la tipologia di rulli **D**

Suspended air hydraulic pit jack, fully automatic, suitable for lifting heavy vehicles or for the assistance and maintenance of speed and differential gears. Movement inside the pit is guaranteed by the 4 rollers with bearings, supplied with the jacking beam.

Sollevatore oleopneumatico da fossa sospeso, completamente automatico adatto al sollevamento di mezzi pesanti o all'assistenza e alla manutenzione di cambi e differenziali. Lo spostamento all'interno della fossa è garantito dai 4 rulli con cuscinetti, forniti con la traversa.

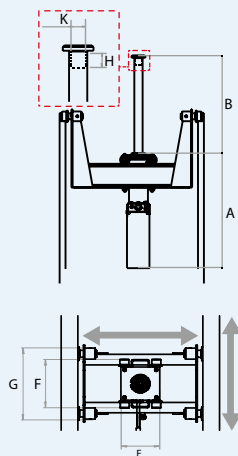

APPLICATIONS

APPLICAZIONI

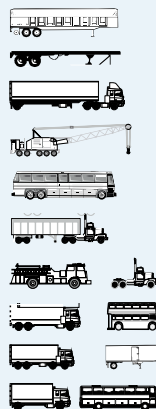

DPLIFT 32 H



DPLIFT 36 H





MORE INFO!
SCOPRI DI PIÙ!

Product name <i>Nome prodotto</i>	DPLIFT 32 H	DPLIFT 36 H
Net weight <i>Peso</i>	734 lbs 333 kg	783 lbs 355 kg
Working pressure <i>Pressione utilizzo</i>	116-145 psi 8-10 bar	116-145 psi 8-10 bar
Max stroke <i>Corsa max.</i>	23.6 in 600 mm	31.5 in 800 mm
Min. height <i>Altezza min.</i>	31.1 in 790 mm	31.1 in 790 mm
Pistons <i>Sfilii</i>	1	1
A	31.1 in 790 mm	35 in 890 mm
B	23.6 in 600 mm	31.5 in 800 mm
E	12.2 in 310 mm	12.2 in 310 mm
F	10.6 in 270 mm	10.6 in 270 mm
G	13.7 in 350 mm	13.7 in 350 mm

A TONS
TONNELLATE

B BEAM HEIGHT
ALTEZZA TRAVERSA

C BEAM LENGHT
LARGHEZZA TRAVERSA

D ROLLERS TYPE
TIPOLOGIA RULLI

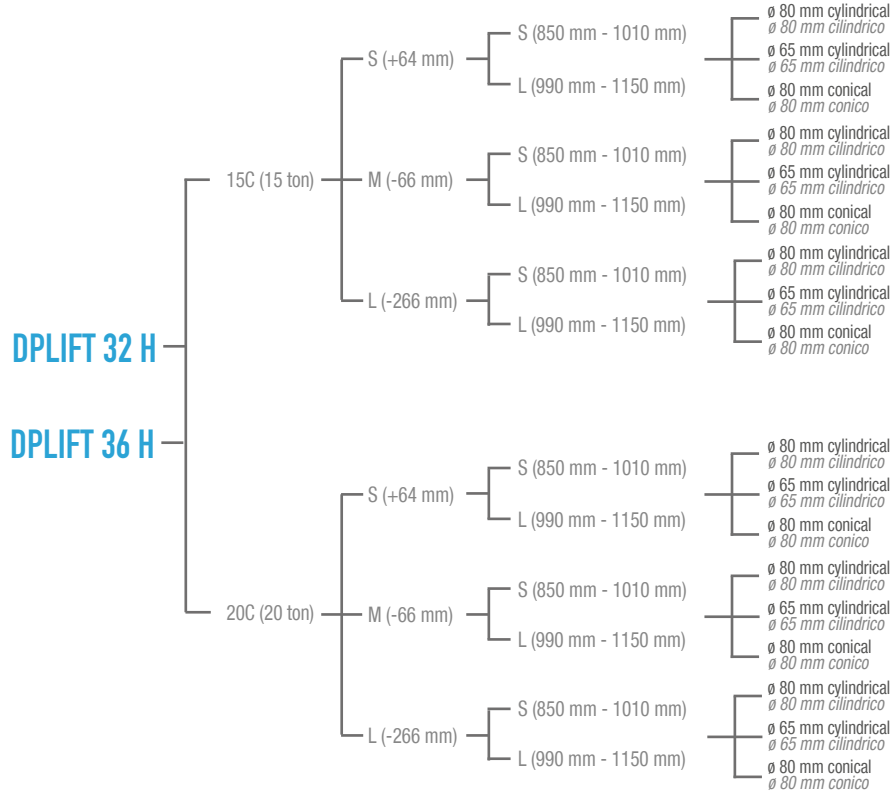

WHEELED PIT JACKS SOLLEVATORI DA FOSSA CARRELLATI

The pit jacks range is aimed at the heavy vehicles sector and is composed by many different models and customizations to satisfy all requirements. We use 2 different capacities: 10/20t. (11/22 ton) e 15/30t (17/33 ton). They can be matched with 2 wheel systems (A: air wheels - 1200 Kg capacity; S: spring wheels - 600 Kg capacity) and with 2 different hydraulic control units.

La gamma di sollevatori da fossa si rivolge principalmente al settore veicoli pesanti e vanta diversi modelli e personalizzazioni mirati a soddisfare ogni esigenza. Abbiamo a disposizione 2 portate differenti: 10/20t. (11/22 ton) e 15/30t (17/33 ton). Ad esse affianchiamo 2 sistemi di ruote (A: ruote ad aria - portata 1200 Kg; S: ruote a molla - portata 600 Kg) e 2 diverse centraline oleopneumatiche.

HOW TO ORDER

- 1 select the capacity **A**
- 2 select the wheel type **B**
- 3 select the power unit type **C**

COME ORDINARE

- 1 selezionare la portata **A**
- 2 selezionare il sistema di ruote **B**
- 3 selezionare il tipo di centralina **C**

A TONS
TONNELLATE

B WHEELS
RUOTE

C POWER UNIT
CENTRALINA

DPLIFT 28

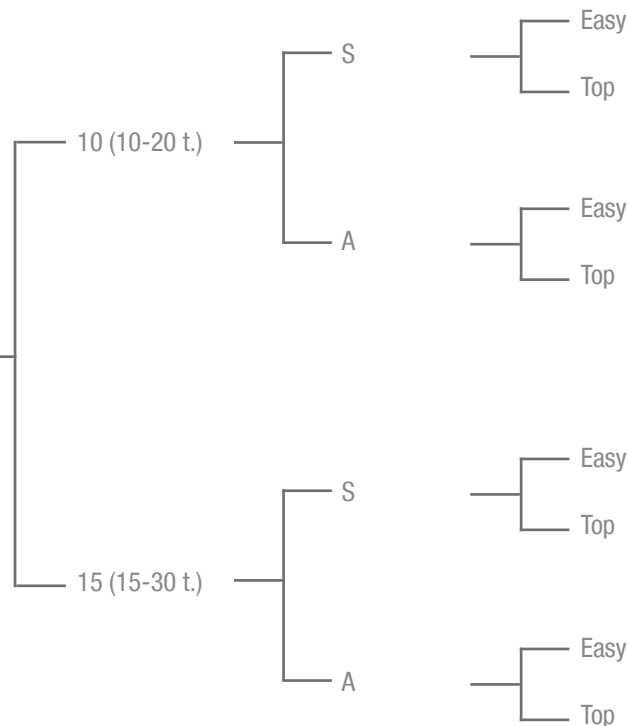

WHEELED PIT JACKS SOLLEVATORI DA FOSSA CARRELLATI

Wheeled air operated hydraulic pit jack, fully automatic, suitable for lifting heavy vehicles or for the assistance and maintenance of speed and differential gears. The range is ideal for all workshops with communicating pits and for working under lifts.

Sollevatore oleopneumatico da fossa carrellato, completamente automatico adatto al sollevamento di mezzi pesanti o all'assistenza e alla manutenzione di cambi e differenziali. Ideale per tutte le officine con fosse comunicanti e per operazioni sotto i ponti sollevatori.

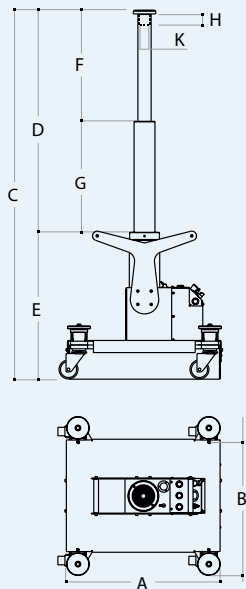

APPLICATIONS APPLICAZIONI

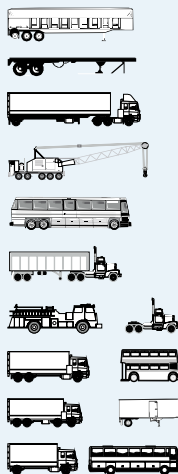

paoli

DPLIFT 28

Product name <i>Nome prodotto</i>	DPLIFT 28
Net weight <i>Peso</i>	250 kg - 551 lbs
Working pressure <i>Pressione utilizzo</i>	8-10 bar - 116-145 psi
Max stroke <i>Corsa max.</i>	1185 mm - 46.7 in
Min. height <i>Altezza min.</i>	800 mm - 31.5 in
Pistons <i>Sfilì</i>	2
A	33.46 in - 850 mm
B	31.5 in - 800 mm
C	78.15 in - 1985 mm
D	46.65 in - 1185 mm
E	31.5 in - 800 mm
F	23.62 in - 600 mm
G	23.03 in - 585 mm
H	2.36 in - 60 mm
K	2.17 in - 55 mm

TOP VERSION VERSIONE TOP



Hydraulic control unit for pit jacks.
Centralina oleopneumatica per sollevatori da fossa.

- ① Quick approach
Avvicinamento rapido

- ② Lifting
Sollevamento

- ③ Quick descent
Discesa rapida

- ④ Adjusting motor speed/lifting
Regolazione velocità motore/sollevamento

- ⑤ Motor speed/lifting selector
Selettore velocità motore/sollevamento

- ⑥ Fine jack drop adjustment
Discesa millimetrica

EASY VERSION VERSIONE EASY



Hydraulic control unit for pit jacks.
Centralina oleopneumatica per sollevatori da fossa.

- ① Quick approach
Avvicinamento rapido

- ② Lifting
Sollevamento

- ③ Quick descent
Discesa rapida

MANUAL VERSION VERSIONE MANUALE

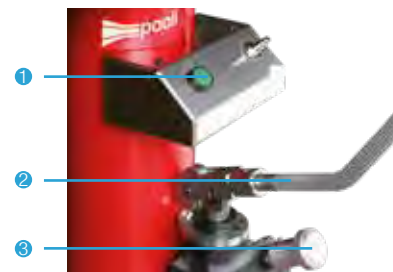

Hydraulic control unit for pit jacks.
Centralina oleopneumatica per sollevatori da fossa.

- ① Quick approach
Avvicinamento rapido

- ② Lifting
Sollevamento

- ③ Descent
Discesa

SMART LIFT SOLLEVATORE SMART

- The original system of compact and fast lifting for the automotive market
- The SMART LIFT enables you to work at a right height for: bodyshops, garages and tyreshops
- With its small size, you can easily place the lift under any type of car, and then work in the same way as with any other lift
- *Il sollevatore portatile per i professionisti dell'automobile*
- *Pratico e facile da maneggiare, adatto a tutti i tipi di officine, carrozzerie e gommisti*
- *Di dimensioni ridotte, si colloca sotto ogni tipo di vettura e permette di fare tutti i lavori come su un qualsiasi ponte*



Product code <i>Codice prodotto</i>	B.37.05.01.0055
Max load admitted <i>Caricamento max. consentito</i>	5500 lbs 2500 kg
Max height <i>Altezza max.</i>	21.65 in 550 mm
Min height <i>Altezza min.</i>	5.12 in 130 mm
Max width <i>Larghezza min.</i>	24.64 in 626 mm
Min width <i>Larghezza min.</i>	54.4 in 1382 mm
Max length <i>Lunghezza max.</i>	81.1 in 2060 mm
Weight <i>Peso</i>	335 lbs 152 kg
Pneumatic circuit pressure <i>Pressione pneumatica del circuito</i>	87/116 psi 6/8 bar
Ascent time <i>Tempo di salita</i>	13 sec
Descent time <i>Tempo di discesa</i>	17 sec.

Large lifting pad
Grande area di sollevamento

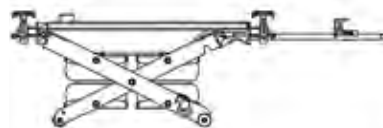

Protection valve, conforming to CE standards
Valvola di protezione, conforme agli standard CE

Top quality airspring
for highest safety
Sospensioni pneumatiche di alta qualità per la massima sicurezza



360° swiveling wheels
Ruote piroettanti 360°

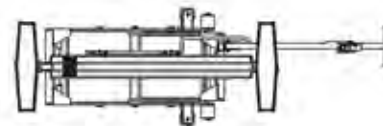

AXLE STANDS COLONNETTE DI SOSTEGNO

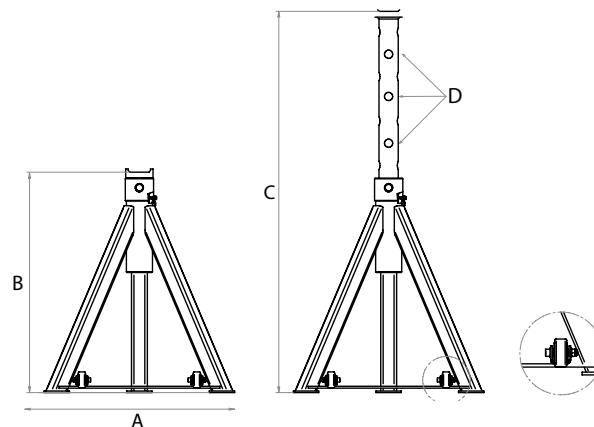

Name Nome	Product code Codice prodotto	Capacity Portata	Net weight Peso	A	B	C	D	Wheels Ruote
DP05-048	B.37.07.01.0011	5,5 ton - 5 t	15.4 lbs - 7 kg	13.39 in - 340 mm	12.2 in - 310 mm	18.9 in - 480 mm	3	
DP05-073	B.37.07.01.0010	5,5 ton - 5 t	20.9 lbs - 9,5 kg	17.72 in - 450 mm	17.52 in - 445 mm	28.74 in - 730 mm	5	
DP05-120	B.37.07.01.0009	5,5 ton - 5 t	35.3 lbs - 16 kg	26.77 in - 680 mm	27.36 in - 695 mm	47.24 in - 1200 mm	8	●
DP10-048	B.37.07.01.0012	11 ton - 10 t	22 lbs - 10 kg	13.78 in - 350 mm	12.2 in - 310 mm	18.9 in - 480 mm	3	
DP10-073	B.37.07.01.0013	11 ton - 10 t	29.8 lbs - 13,5 kg	17.32 in - 440 mm	17.52 in - 445 mm	28.74 in - 730 mm	5	
DP10-120	B.37.07.01.0014	11 ton - 10 t	47.4 lb - 21,5 kg	26.77 in - 680 mm	27.36 in - 695 mm	47.24 in - 1200 mm	8	●
DP15-048	B.37.07.01.0015	16.5 ton - 15 t	28.7 lbs - 13 kg	13.78 in - 350 mm	12.2 in - 310 mm	18.9 in - 480 mm	3	
DP15-073	B.37.07.01.0016	16.5 ton - 15 t	38.6 lbs - 17,5 kg	17.32 in - 440 mm	17.52 in - 445 mm	28.74 in - 730 mm	5	
DP15-120	B.37.07.01.0017	16.5 ton - 15 t	60.6 lbs - 27,5 kg	26.77 in - 680 mm	27.6 in - 695 mm	47.24 in - 1200 mm	8	●
DP20-048	B.37.07.01.0018	22 ton - 20 t	29.8 lbs - 13,5 kg	13.78 in - 350 mm	12.2 in - 310 mm	18.9 in - 480 mm	3	
DP20-073	B.37.07.01.0019	22 ton - 20 t	40.8 lbs - 18,5 kg	17.32 in - 440 mm	17.52 in - 445 mm	28.74 in - 730 mm	5	
DP20-120	B.37.07.01.0020	22 ton - 20 t	66.1 lbs - 30 kg	26.77 in - 680 mm	27.36 in - 695 mm	47.24 in - 1200 mm	8	●

AXLE STANDS AND TROLLEYS COLONNETTE DI SOSTEGNO E CARRELLI

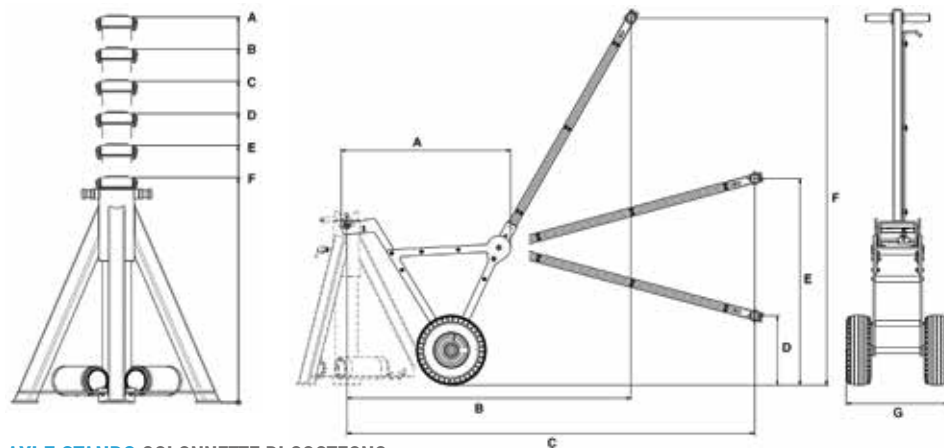

AXLE STANDS COLONNETTE DI SOSTEGNO

Name Nome	Product code Codice prodotto	Capacity Portata	Net weight Peso	Positions Posizioni	A	B	C	D	E	F
DP20-120 M	B.37.07.01.0082	22 ton 20 t	110 lbs 50 kg	6	47.2 in 1200 mm	43.3 in 1100 mm	39.3 in 1000 mm	35.4 in 900 mm	31.4 in 800 mm	27.5 in 700 mm
DP40-120 M	B.37.07.01.0078	44 ton 40 t	110 lbs 50 kg	6	47.2 in 1200 mm	43.3 in 1100 mm	39.3 in 1000 mm	35.4 in 900 mm	31.4 in 800 mm	27.5 in 700 mm
DP50-100 M	B.37.07.01.0080	55.1 ton 50 t	253 lbs 115 kg	6	Ø47.2 in Ø120 mm	39.3 in 1000 mm	35.4 in 900 mm	31.4 in 800 mm	27.5 in 700 mm	23.6 in 600 mm
DP75-100 M	B.37.07.01.0079	83 ton 75 t	253 lbs 115 kg	6	Ø47.2 in Ø120 mm	39.3 in 1000 mm	35.4 in 900 mm	31.4 in 800 mm	27.5 in 700 mm	23.6 in 600 mm

TROLLEYS CARRELLI

Name Nome	Product code Codice prodotto	Net weight Peso	A	B	C	D	E	F	G
DP6629	B.37.07.01.0083	50.4 lbs 22.9 kg	27.2 in 691 mm	45.5 in 1158 mm	65.4 in 1662 mm	11.1 in 283 mm	33.1 in 842 mm	58.8 in 1496 mm	14.4 in 418 mm
DP6630	B.37.07.01.0084	48 lbs 21,8 kg	25 in 635 mm	47.4 in 1204 mm	64.2 in 1631 mm	5.5 in 142 mm	27.4 in 697 mm	16.4 in 1405 mm	14.4 in 418 mm



AIR SUPPLY SYSTEMS

In order to allow any impact wrench to work properly and therefore to reduce unexpected extraordinary maintenance costs, it is essential to provide a good compressed air system.

To get a good quality compressed air system you need:

- Compressor: the capacity and pressure of the compressor must be sufficient to grant the correct working conditions for the tool.
- FRL group: essential to avoid blockages and prevent damage to the line and the impact wrench.
- Couplings and hoses: must always be of the correct size and type.

ALIMENTAZIONE ARIA COMPRESSA

Possedere un buon impianto dell'aria compressa è il requisito fondamentale affinché qualsiasi utensile pneumatico possano funzionare correttamente e ridurre costi imprevisti di manutenzione straordinaria. Per ottenere un impianto di qualità dell'aria compressa sono necessari:

- *Compressore: con capacità e pressione sufficienti per garantire all'avvitatore le corrette condizioni di funzionamento.*
- *Gruppo FRL: fondamentale per evitare intasamenti e prevenire danni alla linea e all'avvitatore*
- *Tubi e raccordi: devono essere sempre di dimensioni e qualità corrette.*

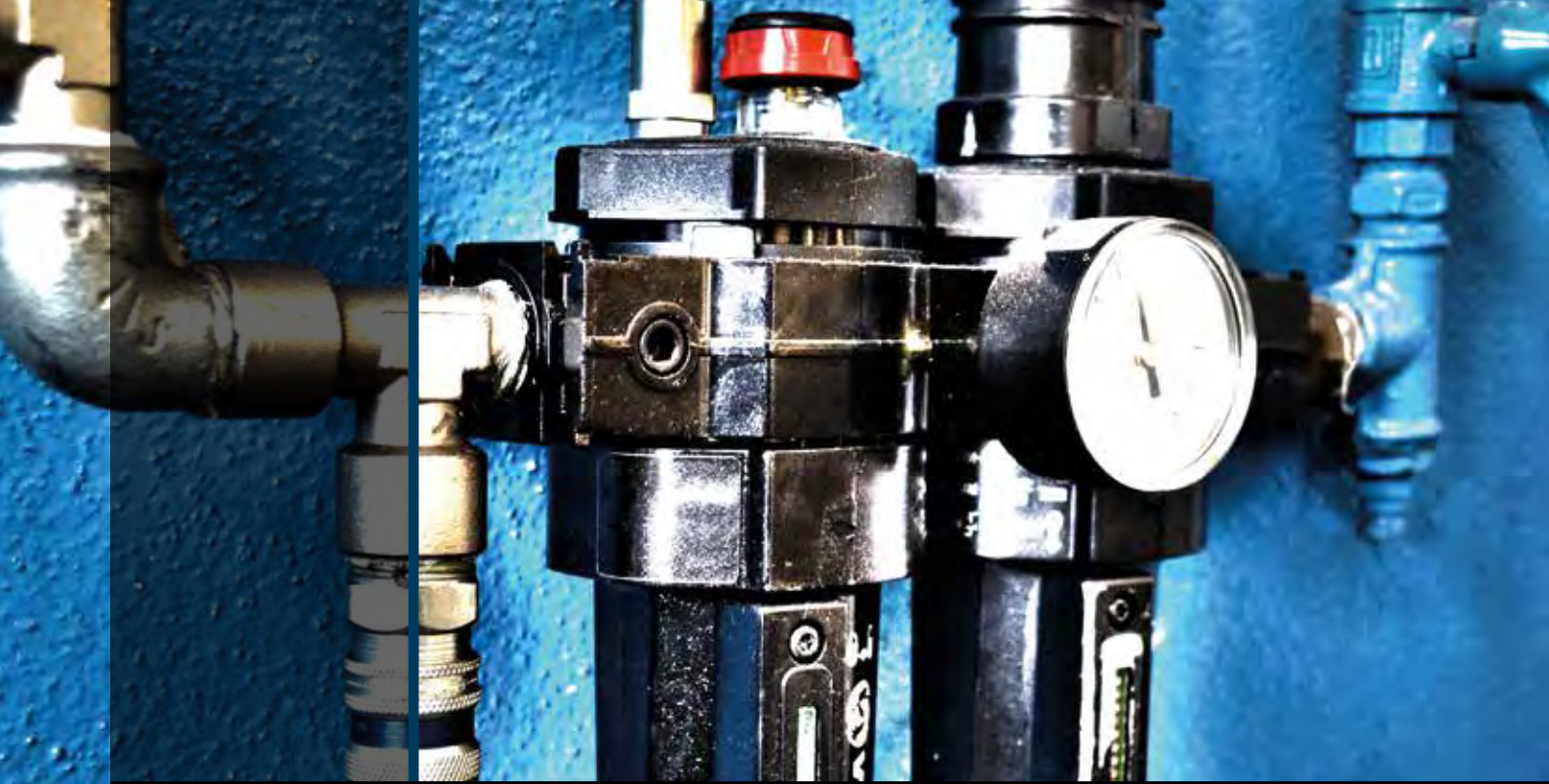

AIR SUPPLY SYSTEMS
ALIMENTAZIONE ARIA COMPRESSA

AIR SUPPLY SYSTEM IN WORKSHOPS

SISTEMA DI ALIMENTAZIONE AD ARIA NELLE OFFICINE

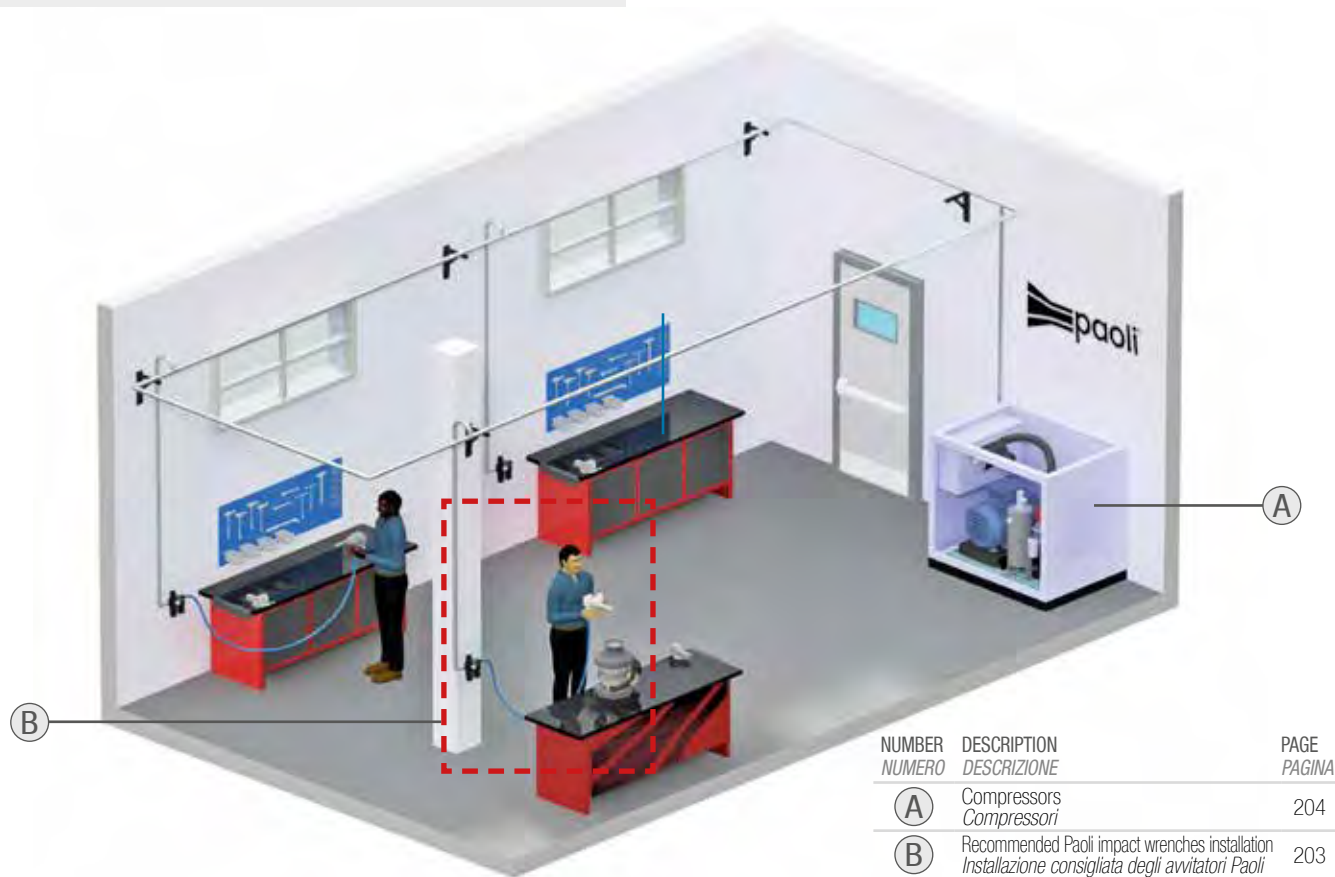

NUMBER NUMERO	DESCRIPTION DESCRIZIONE	PAGE PAGINA
(A)	Compressors <i>Compressori</i>	204
(B)	Recommended Paoli impact wrenches installation <i>Installazione consigliata degli avvitatori Paoli</i>	203

RECOMMENDED PAOLI IMPACT WRENCHES INSTALLATION

INSTALLAZIONE CONSIGLIATA DEGLI AVVITATORI PAOLI

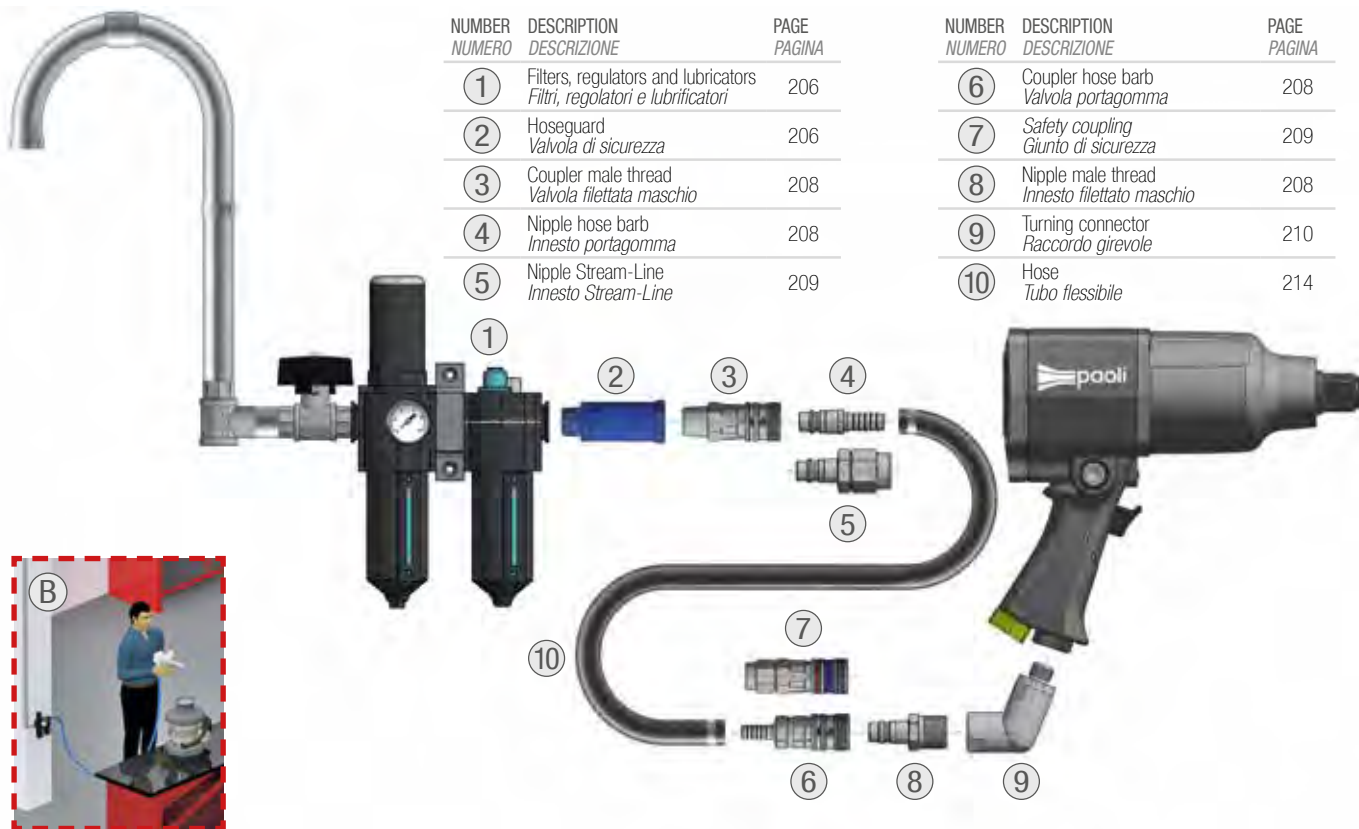

NUMBER NUMERO	DESCRIPTION DESCRIZIONE	PAGE PAGINA
①	Filters, regulators and lubricators <i>Filtri, regolatori e lubrificatori</i>	206
②	Hoseguard <i>Valvola di sicurezza</i>	206
③	Coupler male thread <i>Valvola filettata maschio</i>	208
④	Nipple hose barb <i>Innesto portagomma</i>	208
⑤	Nipple Stream-Line <i>Innesto Stream-Line</i>	209

NUMBER NUMERO	DESCRIPTION DESCRIZIONE	PAGE PAGINA
⑥	Coupler hose barb <i>Valvola portagomma</i>	208
⑦	Safety coupling <i>Giunto di sicurezza</i>	209
⑧	Nipple male thread <i>Innesto filettato maschio</i>	208
⑨	Turning connector <i>Raccordo girevole</i>	210
⑩	Hose <i>Tube flessibile</i>	214

COMPRESSORS COMPRESSORI

HIGH PRESSURE COMPRESSORS COMPRESSORI ALTA PRESSIONE

DPH220



Product code <i>Codice prodotto</i>	B.21.0102
Operating pressure <i>Pressione di esercizio</i>	300 bar 4350 psi
Engine <i>Motore</i>	Single-phase Electric 2,2kW - 3,0HP
Noise level <i>Livello di rumorosità</i>	79dB
Dry weight <i>Peso a secco</i>	42,5 kg 93,7 lb
Capacity <i>Portata</i>	100 l/min - 3,5 CFM 6 m ³ /h
Dimensions <i>Dimensioni</i>	58x41x41 cm 22.8x16.1x16.1 in

LOW PRESSURE COMPRESSORS COMPRESSORI BASSA PRESSIONE



DPL270 E - 4.0 P



DPL500 E - 7.5 P



DPL500 E - 11.0 V ES

Product name <i>Nome prodotto</i>	DPL270 E - 4.0 P	DPL500 E - 7.5 P	DPL500 E - 11.0 V ES
Product code <i>Codice prodotto</i>	G.04.02.0005	G.04.02.0006	G.04.02.0007
Description <i>Descrizione</i>	Compressore a pistone <i>Piston compressor</i>		Compressore a vite <i>Screw compressor</i>
Power <i>Potenza</i>	4 kW - 5.5 HP	7.5 kW - 10 HP	11 kW - 15 HP
Tank capacity <i>Capacità serbatoio</i>	270 l	500 l	500 l
Max working pressure <i>Pressione max di lavoro</i>	11 bar - 159 psi	11 bar - 159 psi	10 bar - 145 psi
Noise level <i>Livello rumorosità</i>	78dB	77dB	68dB
Net weight <i>Peso netto</i>	166 kg - 366 lb	320 kg - 705.5 lb	340 kg - 749.5 lb
Air intake <i>Aria aspirata</i>	660 l/min - 23.5 CFM	1182 l/min - 42 CFM	
Free air delivery <i>Aria resa</i>			1500 l/min - 52.95 CFM
Dimensions <i>Dimensioni</i>	155x58x122 cm	198x60x142 cm	190x70x200 cm

The whole range is available on demand.
L'intera gamma è disponibile su richiesta.

DPE120 D - 7.5 E



Air or electrical power
production
*Produzione di aria o
energia elettrica*

Product code <i>Codice prodotto</i>	G.04.01.0003
Engine <i>Motore</i>	4-stroke diesel engine with electric starter 10.1 HP - 7.5 kW
Air tank <i>Serbatoio aria</i>	120 l
Fuel tank <i>Serbatoio carburante</i>	4,3 l
Operating pressure <i>Pressione di esercizio</i>	12 bar - 174 psi
Weight <i>Peso</i>	220 kg - 486 lb
Dimensions <i>Dimensioni</i>	1200x510x1100 mm 47,2x20x43,3 in

Also available: G.04.02.0003
Air production compressor DPE120 D - 8.0
Disponibile anche: compressore per la produzione d'aria

DPE120 B - 8.0 E



Air or electrical power
production
*Produzione di aria o
energia elettrica*

Product code <i>Codice prodotto</i>	G.04.01.0004
Engine <i>Motore</i>	Air cooled 4-stroke OHV petrol engine 10.7 HP - 8 kW
Air tank <i>Serbatoio aria</i>	120 l
Fuel tank <i>Serbatoio carburante</i>	6,1 l
Operating pressure <i>Pressione di esercizio</i>	12 bar - 174 psi
Weight <i>Peso</i>	185 kg - 408 lb
Dimensions <i>Dimensioni</i>	1200x510x990 mm 47,2x20x39 in

Also available: G.04.02.0004
air production compressor DPE120 B - 6.3
Disponibile anche: compressore per la produzione d'aria

HOSEGUARD VALVOLA DI SICUREZZA

The Hoseguard offers an efficient protection to pneumatic systems in the event of a broken compressed air hose. When the volume of air exceeds a set value, the air supply is immediately shut off by the Hoseguard.

- It protects users, machinery and plant
- Compatible with all pneumatic systems
- Reliable and tamperproof
- No adjustment necessary
- Light and compact

La valvola di sicurezza Hoseguard offre una protezione efficace ai sistemi pneumatici in caso di rottura di un tubo dell'aria compressa. Quando il volume d'aria supera un valore impostato, l'alimentazione viene immediatamente disattivata dall'Hoseguard.

- *Protegge utenti, macchinari e impianti*
- *Compatibile con tutti i sistemi pneumatici*
- *Affidabile e a prova di manomissione*
- *Nessuna regolazione necessaria*
- *Leggero e compatto*



Product code
Codice prodotto B.42.0116

Connection
Connessione 1/2" NPT
High Flow

Max inlet pressure
Working temperature range

*Pressione max in entrata:
Temperatura di utilizzo:*

Other models
available on
demand.
*Altri modelli
disponibili su
richiesta.*

18 bar - 255 psi
-20° C / +80° C

74 SERIES SERIE 74

- Filter-regulator group with pressure gauge and lubricator
- With bracket suitable for wall mounting
- Automatic drain
- Built-in overpressure exhaust
- Inlet: 1/2".
- *Gruppo filtro-regolatore con manometro e lubrificatore*
- *Provisto di staffa per fissaggio a parete*
- *Dispositivo drenaggio condensa automatico*
- *Scarico della sovrappressione incorporato*
- *Attacco: 1/2".*



Product code
Codice prodotto B.45.0002

Capacity
Portata 6000 Nl/min

P_{in} Max 17 bar
246 psi

P_{out} 0,4-10 bar
6-145 psi

Height
Altezza 287 mm
11.3 in

Width
Larghezza 174 mm
6.85 in

200 SERIES SERIE 200

- Filter-regulator group with manometer and lubricator
- With bracket suitable for wall mounting
- Adjustment hand grip with locking device
- Filter with protection cup and quick draining
- Inlet: 1/2"
- Gruppo filtro-regolatore con manometro e lubrificatore
- Provvisto di staffa per fissaggio a parete
- Manopola di regolazione con dispositivo di blocco
- Filtro con tazza di protezione e scarico rapido
- Attacco: 1/2"



Product code <i>Codice prodotto</i>	B.45.0013
Capacity <i>Portata</i>	5000 NI/min
P_in Max	16 bar 232 psi
P_out	0,5-12 bar 7-174 psi
Height <i>Altezza</i>	223 mm 8.78 in
Width <i>Larghezza</i>	143 mm 5.63 in

300 SERIES SERIE 300

- Filter-regulator group with manometer and lubricator
- With bracket suitable for wall mounting
- Adjustment hand grip with locking device
- Filter with protection cup and quick draining
- Inlet: 1" and 3/4"
- Gruppo filtro-regolatore con manometro e lubrificatore
- Provvisto di staffa per fissaggio a parete
- Manopola di regolazione con dispositivo di blocco
- Filtro con tazza di protezione e scarico rapido
- Attacco: 1" e 3/4"



Product code <i>Codice prodotto</i>	B.45.0012 (1") B.45.0014 (3/4")
Capacity <i>Portata</i>	8000 NI/min
P_in Max	16 bar 232 psi
P_out	0,5-12 bar 7-174 psi
Height <i>Altezza</i>	276 mm 10.86 in
Width <i>Larghezza</i>	261 mm 10.2 in

Description <i>Descrizione</i>	FOR 1/2" IMPACT WRENCHES (Ø 7.6 MM) PER AVVITATORI DA 1/2" (Ø 7.6 MM)		FOR 3/4" AND 1" IMPACT WRENCHES (Ø 10.4 MM) PER AVVITATORI DA 3/4" E 1" (Ø 10.4 MM)	
	Product code <i>Codice prodotto</i>	Connection <i>Connessione</i>	Product code <i>Codice prodotto</i>	Connection <i>Connessione</i>
Coupler hose barb <i>Valvola portagomma</i>	B.42.0085	ø8 mm (5/16")		
	B.42.0086	ø10 mm (3/8")		
Coupler male thread <i>Valvola filettata maschio</i>	B.42.0088	1/4"		
	B.42.0050	3/8"		
	B.42.0051	1/2"	B.42.0049	1/2"
Nipple hose barb <i>Innesto portagomma</i>	B.42.0029	ø8 mm (5/16")		
	B.42.0063	ø10 mm (3/8")		
Nipple male thread <i>Innesto filettato maschio</i>	B.42.0031	1/4"		
	B.42.0008	3/8"		
			B.42.0014	1/2"
		B.42.0034	ø13 mm (1/2")	
		B.42.0035	ø16 mm (5/8")	

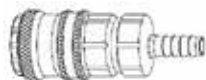

Max working pressure
Working temperature range

Pressione max di esercizio: 16 bar - 232 psi
Temperatura di utilizzo: -20° C / +100° C

STREAM-LINE COUPLINGS RACCORDI STREAM-LINE



Stream-line couplings simply and effectively clamp the hose to the coupling by means of a threaded nut.

- No hose clip required.
- Easy to use with only one hand
- Low coupling force

Max working pressure:
16 bar - 232 psi

Working temperature range:
-20° C / +100° C

I raccordi stream-line bloccano in modo semplice ed efficace il tubo flessibile al raccordo grazie al dado filettato.

- Non sono necessarie fascette stringitubo.
- Semplicità d'uso con una sola mano.
- Minore forza di accoppiamento.

Pressione max di esercizio:
16 bar - 232 psi

Temperatura di utilizzo:
-20° C / +100° C



FOR ½" IMPACT WRENCHES (Ø 7.6 MM)
PER AVVITATORI DA ½ (Ø 7.6 MM)

Description <i>Descrizione</i>	Product code <i>Codice prodotto</i>	Connection <i>Connessione</i>
Safety coupling <i>Giunto di sicurezza</i>	B.42.0090	8 x 12 mm
Nipple Stream-Line <i>Innesto Stream-Line</i>	B.42.0091	8 x 12 mm

FOR ¾" AND 1" IMPACT WRENCHES (Ø 10.4 MM)
PER AVVITATORI DA ¾" E 1" (Ø 10.4 MM)

Description <i>Descrizione</i>	Product code <i>Codice prodotto</i>	Connection <i>Connessione</i>
Safety coupling <i>Giunto di sicurezza</i>	B.42.0092	13 x 18 mm
Nipple Stream-Line <i>Innesto Stream-Line</i>	B.42.0093	13 x 18 mm

TURNING CONNECTORS RACCORDI GIREVOLI

The patented turning connectors system makes flexible and multidirectional every hoses. No more premature wear of the feeding hose and easier to use thanks to the lack of torsion of the hose, which remains in the ideal working position.

The product allows a fluid and constant passage of oil, water, hydrocarbons and solvents

Il sistema a raccordo girevole brevettato rende flessibile e multidirezionale ogni tubo. Niente più usura prematura del tubo di alimentazione e maggior facilità di utilizzo grazie alla mancanza di torsione del tubo, che rimane nella posizione di lavoro ideale.

Il prodotto consente un passaggio fluido e costante di olio, acqua, idrocarburi e solventi.



Description Descrizione

- 360° turning
- Girevoli a 360°

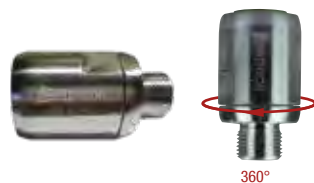

- 360° turning
- 90° flexing hose connectors
- Girevoli a 360°
- Pieghevoli a 90°

Hydraulics Idraulici

3 rotation
3 rotazioni

Standard rotation
Rotazione standard

Straight rotation
Rotazione dritta

Two cross-sections
Due sezioni trasversali



Pneumatics Pneumatici

One cross-sections
Una sezione trasversale



Description Codice prodotto	Thread Filettatura	Connection Connessione	Internal diameter Diametro interno
B.43.0010	Male/Female Maschio/Femmina	1/4" BSP	7 mm
B.43.0011	Male/Female Maschio/Femmina	1/2" BSP	11 mm
B.43.0012	Male/Female Maschio/Femmina	3/4" BSP	16 mm
B.43.0013	Male/Female Maschio/Femmina	1" BSP	25 mm
B.43.0071	Male/Female Maschio/Femmina	1/4" BSP	30 mm
B.43.0019	Male/Female Maschio/Femmina	1/2" BSP	40 mm
B.43.0021	Female/Female Femmina/Femmina	1/4" BSP	7 mm
B.43.0032	Female/Female Femmina/Femmina	3/8" BSP	11 mm
B.43.0072	Female/Female Femmina/Femmina	1" BSP	25 mm
B.43.0028	Female/Female Femmina/Femmina	2" BSP	40 mm
B.43.0081	Male/Female Maschio/Femmina	1/4" BSP	6 mm
B.43.0049	Male/Female Maschio/Femmina	3/8" BSP	6 mm
B.43.0073	Male/Male Maschio/Maschio	M16X1.5	6 mm
B.43.0080	Female/Male Femmina/Maschio	1/4" BSP	6 mm
B.43.0074	Female/Male Femmina/Maschio	3/8" BSP	6 mm
B.43.0075	Female/Male Femmina/Maschio	1/4" BSP	6 mm
B.43.0076	Female/Male Femmina/Maschio	3/8" BSP	6 mm
B.43.0006	Male/Female Maschio/Femmina	1/4" Gas	7 mm
B.43.0004	Male/Female Maschio/Femmina	1/4" NPT	7 mm
B.43.0001	Male/Female Maschio/Femmina	3/8" Gas	11 mm
B.43.0005	Male/Female Maschio/Femmina	3/8" NPT	11 mm
B.43.0007	Male/Female Maschio/Femmina	1/2" Gas	11 mm
B.43.0077	Male/Female Maschio/Femmina	1/2" NPT	11 mm
B.43.0039	Male/Female Maschio/Femmina	1" Gas	16 mm
B.43.0078	Male/Female Maschio/Femmina	1" ZVA	16 mm
B.43.0060	Male/Female Maschio/Femmina	3/4" Gas	16 mm
B.43.0079	Male/Female Maschio/Femmina	3/4" ZVA	16 mm

TURNING CONNECTORS RACCORDI GIREVOLI

Description <i>Descrizione</i>	Product code <i>Codice prodotto</i>	Connection <i>Connessione</i>	Internal diameter <i>Diametro interno</i>	Working pressure <i>Pressione di utilizzo</i>
<ul style="list-style-type: none"> • Optimum flow rate for all pipe curves. • <i>Portata ottimale per tutte le curve del tubo</i> 	on demand	1/4"-3/8"	6 mm	100 bar
	on demand	1/4"-3/8"	7 mm	40 bar
	on demand	3/8"-1/2"	11 mm	20 bar
	on demand	3/4"-1"	16 mm	20 bar
	on demand	1"- 1 1/4"	25 mm	30 bar
	on demand	1 1/2" - 2"	40 mm	30 bar
	on demand	2 1/2"	65 mm	20 bar
<ul style="list-style-type: none"> • From 90° to 180° flexing hose connectors • <i>Pieghevoli da 90° a 180°</i> 	B.43.0082	M12x1.5	4 mm	250 bar
	B.43.0084	M16x1.5	8 mm	250 bar
	B.43.0085	M18x1.5	10 mm	250 bar
	B.43.0086	M22x1.5	12 mm	250 bar
	B.43.0017	1/4" Gas	7 mm	250 bar

TURNING CONNECTORS RACCORDI GIREVOLI

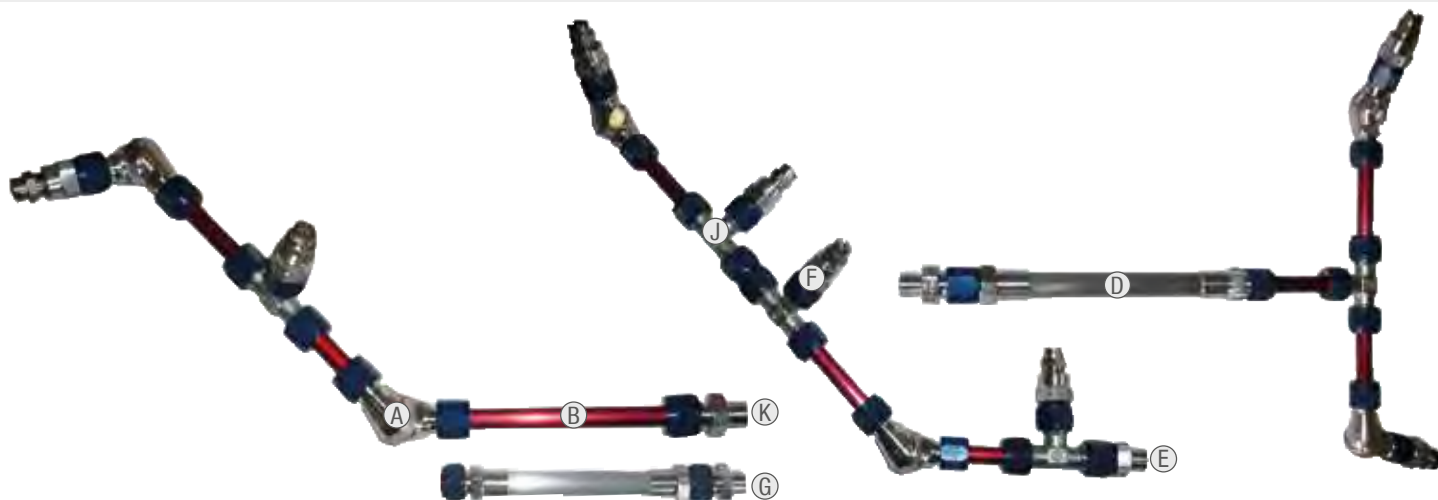

Kit code Codice kit	Connection Connessione	Internal diameter Diametro interno	Kits accessory parts* Accessori Kit*							
B.43.0045	1/8" BSP	4 mm								
B.43.0087	1/4" BSP	8 mm	A Ball connector Raccordo a sfera	B Tube Tubo	J T bypass Raccordo a T	D Telescopic extension Estensione Telescopica	E Male connector Raccordo maschio	F Female connector Raccordo femmina	K Male interface tube Tubo con attacco maschio	G Fem interface tube Tubo con attacco femmina
B.43.0088	1/2" BSP	15 mm								

*Product codes on demand
*Codici prodotto su richiesta

POWER REGULATORS
REGISTRI DI POTENZA



B.16.0001



B.16.0002



B.16.0003



B.16.0004

Product code
Codice prodotto

Connection
Connessione

B.16.0001

3/8" BSP

B.16.0002

3/4" BSP

B.16.0003

1/2" BSP

B.16.0004

1/4" BSP

*Suitable for all the heavy duty impact wrenches models
**Adatti a tutti i modelli di avvitatori heavy duty*

POLYURETHANE HOSES TUBI IN POLIURETANO



Polyurethane hoses extremely flexible and light; spark proof, ideal for light devices; black coloured; working pressure: 10 bar - 145 psi. Suggested for 3/8" e 1/2" impact wrenches. Length on demand.

Tubi in poliuretano estremamente flessibili e leggeri; antiscintilla adatti per attrezzi leggeri; colore nero; pressione di esercizio: 10 bar - 145 psi. Consigliati per avvitatori da 3/8" e 1/2". Lunghezza a richiesta.

Product code Codice prodotto	Ø Inner Ø Interno	Ø External Ø Esterno
B.41.0010	8 mm - 0.315 in	12 mm - 0.472 in
B.41.0011	13 mm - 0.512 in	18 mm - 0.709 in

RUBBER HOSES TUBI IN GOMMA

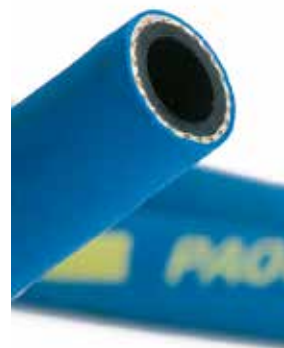

Rubber hoses with textile braid reinforcement; externally with textile effect for an easier grip; excellent resistance to oil and abrasion; blue coloured; working pressure: 20 bar - 290 psi. Suggested for 1" e 3/4" impact wrenches. Length on demand.

Tubi in gomma con inserti tessili; esternamente a impressione di tela per una facile presa; resistenti all'olio ed all'abrasione; colore azzurro; pressione di esercizio: 20 bar - 290 psi. Consigliati per avvitatori da 1" e 3/4". Lunghezza a richiesta.

Product code Codice prodotto	Ø Inner Ø Interno	Ø External Ø Esterno
B.41.0012	8 mm - 0.314 in	17 mm - 0.669 in
B.41.0013	13 mm - 0.512 in	23 mm - 0.906 in
B.41.0014	16 mm - 0.630 in	26 mm - 1.02 in

TWO-HOSES KIT FOR TROLLEYS KIT BITUBO PER CARRELLI



D.02.18.0001

The two-hoses kit for Paoli trolleys includes:

- rubber hose Ø 13x23 - 3 m
- rubber hose Ø 16x26 - 3 m
- 2 hose clamps
- polyolefin heat-resistant sheath - 0,4 m

Il kit bitubo per carrelli Paoli include:

- *tubo di gomma Ø 13x23 - 3 m*
- *tubo di gomma Ø 16x26 - 3 m*
- *2 fascette stringitubo*
- *guaina termoresistente in poliolefina - 0,4 m*

CLAMPED HOSES TUBI CRIMPATI



Technical data

bore size: 10 mm
working pressure: 20 bar

Dati tecnici:

diametro: 10 mm
pressione di esercizio: 20 bar

A - Select length *Selezionare la lunghezza*

Code <i>Codice</i>	Length <i>Lunghezza</i>
B.41.7005	5 m
B.41.7008	8 m
B.41.7010	10 m

B, C - Select couplings *Selezionare i raccordi*

Angle <i>Angolo</i>	1/2"	3/8"
0°	B.41.8001	B.41.8002

HOW TO ORDER

- 1 select the length of the hose (table A)
- 2 select the fittings at both ends of the hose (table B/C)

More items and configurations on demand.

COME ORDINARE

- 1 selezionare la lunghezza del tubo (tabella A)
- 2 selezionare i raccordi per entrambe le estremità del tubo (tabella B/C)

Altri elementi e configurazioni a richiesta.



HOSE REELS
ARROTOLATORI

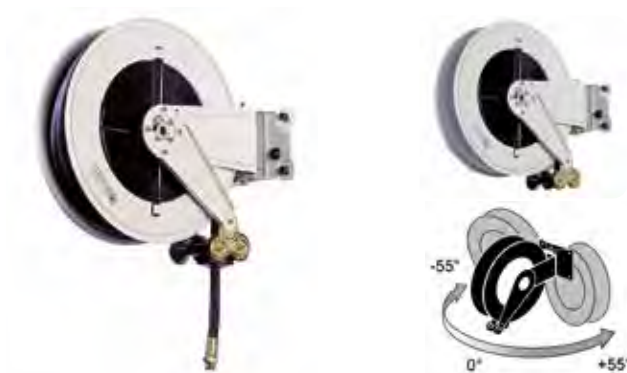

Stainless steel industrial hose reels with ABS shock proof drum.
Avvolgitubo industriali in acciaio inox con tamburo in ABS antiurto.

Product code <i>Codice prodotto</i>	Hose length <i>Lunghezza tubo</i>	Ø hose <i>Ø tubo</i>	Inlet <i>Ingresso</i>	Outlet <i>Uscita</i>
B.33.0003	12 m - 472.44 in	3/8"	F 1/2" G	M 3/8" G
B.33.0004	18 m - 708.67 in	3/8"	F 1/2" G	M 3/8" G
B.33.0005	10 m - 393.7 in	1/2"	F 1/2" G	M 1/2" G
B.33.0006	15 m - 590.55 in	1/2"	F 1/2" G	M 1/2" G

Other models available on demand.
Altri modelli disponibili su richiesta.

MINI AIR FILTER MINI FILTRO ARIA



B.45.0010

- External / internal thread: 1/4 "
- It separates water from the outlet air to guarantee clean air for pneumatic tools
- *Filetto esterno / interno: 1/4"*
- *Separa l'acqua dall'aria in uscita in modo da garantire sempre aria pulita agli utensili pneumatici*

MINI OILER MINI OLIAIORE



B.45.0011

- External / internal thread: 1/4 " (also available 3/8" and 1/2")
- It ensures continuous lubrication of pneumatic tools.
- The oil reservoir is transparent, so that the oil level can be easily checked.
- *Filetto esterno / interno: 1/4" (disponibile anche 3/8" e 1/2")*
- *Garantisce una lubrificazione continua degli utensili pneumatici.*
- *Il serbatoio dell'olio è trasparente, in modo che il livello dell'olio possa essere controllato facilmente.*

MOBILE UNIT FOR EXTERNAL ASSISTANCE UNITÀ MOBILE DI ASSISTENZA ESTERNA



F4 AIR PRESSURE REGULATOR

It keeps high performances also when the bottle is almost empty. It grants constant air flow.

REGOLATORE DI PRESSIONE F4

Mantiene elevate prestazioni anche quando la bombola è quasi vuota. Garantisce flusso d'aria costante



AIR BOTTLE TROLLEY KIT

Accessories included: belt, fixing nut and high pressure hose to connect the air bottle to the air pressure regulator.

KIT CARRELLO

Accessori inclusi: cinghia, ghiera di fissaggio e tubo ad alta pressione per collegare la bombola al regolatore di pressione.



C.02.0051

The mobile unit for external assistance includes:

- No. 1 trolley
- No. 1 18 litres bottle with double connection
- No. 1 air bottle trolley kit
- No. 1 F4 air pressure regulator (DIN air bottle connector included)

L'unità mobile di assistenza esterna include:

- No. 1 carrello
- No. 1 bombola da 18 litri con doppio attacco
- No. 1 kit carrello
- No. 1 regolatore di pressione F4 (attacco DIN incluso)



To be used with the high pressure compressor DPH 220 (page 204).

The compressor compresses up to 300 bar and allows to have more air liters available in the 18 litres bottle.

Da utilizzare con il compressore ad alta pressione DPH 220 (pag. 204).

Il compressore comprime fino a 300 bar e consente di avere più litri di aria disponibili nella bombola da 18 litri.

ACCESSORIES

The Paoli range of accessories includes equipment, accessories and optional items useful for the correct functioning of Paoli impact wrenches, maintaining their optimal conditions in terms of performance and safety and completing their installations.

From impact sockets to torque sockets, from handles to lubricants, Paoli offers its customers a selection of high quality and reliable products designed to meet every need of use from small workshops to large industries.

ACCESSORI

La gamma accessori Paoli include attrezzature, complementi e optional utili al corretto funzionamento degli avvitatori Paoli, al mantenimento delle loro condizioni ottimali in termini di prestazioni e sicurezza e al completamento delle loro installazioni.

Dalle bussole alle barre di torsione, dalle maniglie ai lubrificanti, Paoli offre ai propri clienti una selezione di prodotti di alta qualità e affidabilità pensata per soddisfare ogni esigenza di utilizzo dalla piccola officina alla grande industria.



ACCESSORIES
ACCESSORI

IMPACT SOCKETS

BUSSOLE



IMPACT SOCKETS: QUALITY - STRENGTH - COMFORT

The  IMPACT SOCKETS were born 50 years ago to serve the Automotive & Industry sector and also today they represent one of the best Made in Italy design & technology that marks the difference.

Which way?

- No forge but production by CNC machining, to grant more accuracy and robustness.
- Material: hardened steel
- Surface hardness superior to all the actual competition and sharpened angles in the square and in the hexagon too to increase accuracy and durability and to reduce the vibrations of the combination impact wrench-impact socket.

CHIAVI A BUSSOLA : QUALITÀ - ROBUSTEZZA - COMFORT

Nate 50 anni fa al servizio dell'Automotive & Industry, le bussole  rappresentano una delle migliori espressioni del Made in Italy che fa la differenza.

Come?

- *Niente forgiatura. Produzione mediante lavorazione al CNC, per maggiore precisione e robustezza.*
- *Realizzazione in acciaio per tempra.*
- *Durezza superficiale superiore a tutta la concorrenza e angoli del quadro e dell'esagono non raggiati. Le caratteristiche dei profili si mantengono più a lungo, riducendo le vibrazioni nell'utilizzo di avvitatori con massa battente.*

3/4" HEAVY DUTY  IMPACT SOCKETS
 CHIAVI A BUSSOLA  3/4" HEAVY DUTY

mm	C	L
24	B34X24	B34X24L
27	B34X27	B34X27L
30	B34X30	B34X30L

1" HEAVY DUTY  IMPACT SOCKETS
 CHIAVI A BUSSOLA  1" HEAVY DUTY

mm	C	LP
30	B1X30	B1X30L
32	B1X32	B1X32L
33	B1X33	B1X33L

Key: C= Short, L= Long, LP= Long Deep

Legenda: C= Corta, L=Lunga LP=Lunga Profonda



HEAVY DUTY RANGE

CNC MACHINING:
 accuracy and robustness
 LAVORAZIONE CNC:
 precisione e robustezza



Technology and design Made in Italy
 Design e tecnologia Made in Italy



Material: hardened steel
 Materiale: acciaio per tempra

Surface hardness superior to
 all the actual competition

*Durezza superficiale superiore
 a tutta la concorrenza*

For sockets and square drives different from the ones listed or special drawings, PAOLI can execute parts on request.

Per esagoni e/o quadri porta bussola diversi da quelli elencati oppure formati speciali, PAOLI esegue lavorazioni a disegno su richiesta.

SPECIAL IMPACT SOCKETS ON DEMAND

For sockets and square drives different from the ones listed or special drawings,  can execute parts on request.

Do not hesitate to contact us for further information.

Professional Range available with code BCL12X.

CHIAVI A BUSSOLA SPECIALI A RICHIESTA

Per esagoni e/o quadri porta bussola diversi da quelli elencati oppure formati speciali,  esegue lavorazioni a disegno su richiesta.

Non esitate a contattarci per ulteriori informazioni.

Gamma Professionale disponibile con codice BCL12X.



Hex mm	C	L
10	BC12X10	BC12X10L
11	BC12X11	BC12X11L
12	BC12X12	BC12X12L
13	BC12X13	BC12X13L
14	BC12X14	BC12X14L
15	BC12X15	BC12X15L
16	BC12X16	BC12X16L
17	BC12X17	BC12X17L
18	BC12X18	BC12X18L
19	BC12X19	BC12X19L
20	BC12X20	BC12X20L

Key: C= Short, L= Long

- Square drive 1/2"
- Hexagons from 10 to 32 mm

Hex mm	C	L
21	BC12X21	BC12X21L
22	BC12X22	BC12X22L
23	BC12X23	BC12X23L
24	BC12X24	BC12X24L
25	BC12X25	BC12X25L
26	BC12X26	
27	BC12X27	BC12X27L
28	BC12X28	BC12X28L
29	BC12X29	
30	BC12X30	BC12X30L
31	BC12X31	BC12X31L
32	BC12X32	BC12X32L

Legenda: C= Corta, L=Lunga

- Quadri da 1/2"
- Esagoni da 10 a 32 mm

Insert adapters, universal joints and extensions are available on demand.
 Inserti adattatori, snodi e prolunghe sono disponibili su richiesta.

1/2" IMPACT SOCKETS FOR ALLOY WHEELS CHIAVI A BUSSOLA 1/2" PER CERCHI IN LEGA



paoli impact sockets for alloy wheels application allow not to damage the wheel as they have a black teflon part (detached from the metal socket) that can rotate. This feature enables the tyre repairer to work with no worries and avoid marking or scratching the wheel, also in the presence of grains of dust that in the rotation of the socket could damage the wheel.

Le bussole per cerchi in lega paoli offrono il grande vantaggio di aver la parte in teflon nera, staccata dalla bussola in metallo e la stessa può ruotare senza danneggiare il cerchio. Questa caratteristica consente al gommista di lavorare in tranquillità ed evitare di segnare o graffiare il cerchio, anche in presenza di granelli di polvere che nella rotazione della bussola potrebbero danneggiare il cerchio.

Code Codice	Square drive Attacco Quadro	⊘
L02.E009L.001	1/2"	17 mm
L02.E011L.001	1/2"	19 mm
L02.E013L.001	1/2"	21 mm

SUPER THIN WALL IMPACT SOCKETS CHIAVI A BUSSOLA A PARETE ULTRASOTTILE



- Colour codes
- Square drive: 1/2"
- Designed for alloy wheels
- Ultra long life
- Codici colore
- Attacco quadro: 1/2"
- Disegnate per i cerchi in lega
- Extra durata

Code Codice	Square drive Attacco Quadro	⊘	Colour Colore
	1/2"	17 mm	Blue Blu
L02.EK1TL.001	1/2"	19 mm	Gold Oro
	1/2"	21 mm	Red Rosso

SPECIAL IMPACT SOCKETS ON DEMAND

For sockets and square drives different from the ones listed or special drawings,  can execute parts on request.

Do not hesitate to contact us for further information.

Professional Range available with code BCL34X.

CHIAVI A BUSSOLA SPECIALI A RICHIESTA

Per esagoni e/o quadri porta bussola diversi da quelli elencati oppure formati speciali,  esegue lavorazioni a disegno su richiesta.

Non esitate a contattarci per ulteriori informazioni.

Gamma Professionale disponibile con codice BCL34X.



mm	C	L
16	BC34X16	
17	BC34X17	BC34X17L
18	BC34X18	BC34X18L
19	BC34X19	BC34X19L
20	BC34X20	BC34X20L
21	BC34X21	BC34X21L
22	BC34X22	BC34X22L
23	BC34X23	BC34X23L
24	BC34X24	BC34X24L
26	BC34X26	BC34X26L
27	BC34X27	BC34X27L
28	BC34X28	BC34X28L
29	BC34X29	BC34X29L
30	BC34X30	BC34X30L

Key: C= Short, L= Long

- Square drive 3/4"
- Hexagons from 16 to 50 mm

mm	C	L
32	BC34X32	BC34X32L
33	BC34X33	BC34X33L
34	BC34X34	BC34X34L
35	BC34X35	BC34X35L
36	BC34X36	BC34X36L
37	BC34X37	BC34X37L
38	BC34X38	BC34X38L
41	BC34X41	BC34X41L
42	BC34X42	BC34X42L
43	BC34X43	BC34X43L
46	BC34X46	BC34X46L
47	BC34X47	
50	BC34X50	

Legenda: C= Corta, L=Lunga

- Quadri da 3/4"
- Esagoni da 16 a 50 mm

Insert adapters, universal joints and extensions are available on demand.
 Inserti adattatori, snodi e prolunghie sono disponibili su richiesta.

SPECIAL IMPACT SOCKETS ON DEMAND

For sockets and square drives different from the ones listed or special drawings, **paoli** can execute parts on request.

Do not hesitate to contact us for further information.

Professional Range available with code BCL1X.

CHIAVI A BUSSOLA SPECIALI A RICHIESTA

Per esagoni e/o quadri porta bussola diversi da quelli elencati oppure formati speciali, **paoli** esegue lavorazioni a disegno su richiesta.

Non esitate a contattarci per ulteriori informazioni.

Gamma Professionale disponibile con codice BCL1X.



mm	C	LP
21	BC1X21	
22	BC1X22	
23	BC1X23	BC1X23L
24	BC1X24	BC1X24L
26	BC1X26	
27*	BC1X27	BC1X27L
28	BC1X28	BC1X28L
29	BC1X29	
30	BC1X30	BC1X30L
32*	BC1X32	BC1X32L
33*	BC1X33	BC1X33L
34	BC1X34	BC1X34L
35	BC1X35	
36	BC1X36	BC1X36L
37	BC1X37	BC1X37L
38	BC1X38	BC1X38L
41	BC1X41	BC1X41L

mm	C	LP
42	BC1X42	BC1X42L
43	BC1X43	BC1X43L
46	BC1X46	BC1X46L
47	BC1X47	BC1X47L
48	BC1X48	
50	BC1X50	BC1X50L
52	BC1X52	BC1X52L
56	BC1X56	BC1X56L
60	BC1X60	BC1X60L
65	BC1X65	BC1X65L
70	BC1X70	BC1X70L
75	BC1X75	BC1X75L
80	BC1X80	BC1X80L
85	BC1X85	
90	BC1X90	
95	BC1X95	
100	BC1X100	

Key: C= Short, LP= Long Deep
* Heavy Duty available

BC1X27, BC1X30, BC1X32, BC1X33 also available long deep thin and extended 170 mm.

Insert adapters, universal joints and extensions are available on demand.
Inserti adattatori, snodi e prolunghie sono disponibili su richiesta.

Legenda: C= Corta, LP=Lunga Profonda
* Heavy duty disponibile

BC1X27, BC1X30, BC1X32, BC1X33 disponibili anche lunghe profonde sottili e prolungate 170 mm.

SPECIAL IMPACT SOCKETS ON DEMAND

For sockets and square drives different from the ones listed or special drawings, **paoli** can execute parts on request.

Do not hesitate to contact us for further information.

CHIAVI A BUSSOLA SPECIALI A RICHIESTA

Per esagoni e/o quadri porta bussola diversi da quelli elencati oppure formati speciali, **paoli** esegue lavorazioni a disegno su richiesta.

Non esitate a contattarci per ulteriori informazioni.



Hex mm	C	L
41	BC112X41	
42	BC112X42	
43	BC112X43	
46	BC112X46	
47	BC112X47	
48	BC112X48	
50	BC112X50	
52	BC112X52	
55	BC112X55	
56	BC112X56	
60	BC112X60	
65	BC112X65	
70	BC112X70	
75	BC112X75	
80	BC112X80	

Key: C= Short, L= Long

- Square drive 1" 1/2
- Hexagons from 41 to 155 mm

Hex mm	C	L
85	BC112X85	
90	BC112X90	
95	BC112X95	
100	BC112X100	
105	BC112X105	
110	BC112X110	
115	BC112X115	
120	BC112X120	
125	BC112X125	
130	BC112X130	
135	BC112X135	
140	BC112X140	
145	BC112X145	
150	BC112X150	
155	BC112X155	

Legenda: C= Corta, L=Lunga

- Quadri da 1" 1/2
- Esagoni da 41 a 155 mm

Insert adapters, universal joints and extensions are available on demand.
Inserti adattatori, snodi e prolunghe sono disponibili su richiesta.

PAOLI TORQUE SOCKETS BARRE DI TORSIONE PAOLI



Product name <i>Nome prodotto</i>	Product code <i>Codice prodotto</i>	Square drive <i>Attacco quadro</i>	●	Nm*	Ft-lbs	Length <i>Lunghezza mm</i>	Length <i>Lunghezza in</i>
CBT12X6	03.00.000.001	1/2"	6 mm	20	15	143	5,63
CBT12X7	03.00.001.001	1/2"	7 mm	55	41	143	5,63
CBT12X8	03.00.002.002	1/2"	8 mm	80	59	143	5,63
CBT12X9	03.00.003.001	1/2"	9 mm	110	81	143	5,63
CBT12X10	03.00.004.001	1/2"	10 mm	190	140	143	5,63
CBT12X11	03.00.005.001	1/2"	11 mm	300	221	143	5,63
CBT12X12	03.00.006.001	1/2"	12 mm	370	273	143	5,63
CBT12X13	03.00.007.001	1/2"	13 mm	430	317	143	5,63
CBT12X14	03.00.008.001	1/2"	14 mm	470	347	143	5,63
CBT34X6	03.01.000.001	3/4"	6 mm	30	22	195	7,68
CBT34X7	03.01.001.001	3/4"	7 mm	80	59	195	7,68
CBT34X8	03.01.002.001	3/4"	8 mm	140	103	195	7,68
CBT34X9	03.01.003.001	3/4"	9 mm	210	155	195	7,68
CBT34X10	03.01.004.001	3/4"	10 mm	290	214	195	7,68
CBT34X11	03.01.005.001	3/4"	11 mm			195	7,68
CBT34X12	03.01.006.001	3/4"	12 mm	420	310	195	7,68
CBT34X13	03.01.007.001	3/4"	13 mm	460	339	195	7,68
CBT34X14	03.01.008.001	3/4"	14 mm	500	369	195	7,68
CBT34X15	03.01.009.001	3/4"	15 mm	530	391	195	7,68
CBT1X12	03.02.006.001	1"	12 mm	630	465	232	9,13
CBT1X13	03.02.007.001	1"	13 mm	760	561	232	9,13
CBT1X14	03.02.008.001	1"	14 mm	850	627	232	9,13
CBT1X15	03.02.009.001	1"	15 mm	110	811	232	9,13
CBT1X16	03.02.010.001	1"	16 mm	1250	922	232	9,13
CBT1X17	03.02.011.001	1"	17 mm	12350	996	232	9,13
CBT1X18	03.02.012.001	1"	18 mm	1600	1180	232	9,13
CBT1X19	03.02.013.001	1"	19 mm	1750	1291	232	9,13
CBT1X21	03.02.014.001	1"	21 mm	1970	1453	232	9,13
CBT1X23	03.02.015.001	1"	23 mm	2150	1586	232	9,13
CBT1X25	03.02.016.001	1"	25 mm	2250	1660	232	9,13

(*) Indicative torque value: accuracy of +/- 10%

(*) *Valore di coppia indicativo: approssimazione +/- 10%*

Paoli Torque Sockets available on demand.

Barre di torsione Paoli disponibili su richiesta.

1/2" COMMERCIAL TORQUE SOCKETS BARRE DI TORSIONE COMMERCIALI



Product name <i>Nome prodotto</i>	Product code <i>Codice prodotto</i>		Nm*	Ft-lbs	Length <i>Lunghezza mm</i>	Length <i>Lunghezza in</i>
CBTM12X17X75	04.00.000.002	17 mm	75	55	220 mm	8,66
CBTM12X17X95	04.00.000.003	17 mm	95	70	220 mm	8,66
CBTM12X17X110	04.00.000.004	17 mm	110	81	220 mm	8,66
CBTM12X17X120	04.00.000.005	17 mm	120	88,5	220 mm	8,66
CBTM12X19X70	04.00.001.001	19 mm	70	52	220 mm	8,66
CBTM12X19X75	04.00.001.002	19 mm	75	55	220 mm	8,66
CBTM12X19X90	04.00.001.003	19 mm	90	66	220 mm	8,66
CBTM12X19X110	04.00.001.004	19 mm	110	81	220 mm	8,66
CBTM12X19X120	04.00.001.005	19 mm	120	88,5	220 mm	8,66
CBTM12X19X135	04.00.001.006	19 mm	135	100	220 mm	8,66
CBTM12X19X140	04.00.001.007	19 mm	140	103	220 mm	8,66
CBTM12X19X170	04.00.001.008	19 mm	170	125	220 mm	8,66
CBTM12X21X80	04.00.002.001	21 mm	80	59	220 mm	8,66
CBTM12X21X110	04.00.002.002	21 mm	110	81	220 mm	8,66
CBTM12X22X110	04.00.003.002	22 mm	110	81	220 mm	8,66

(*) Indicative torque value: accuracy of +/- 10%

(*) *Valore di coppia indicativo: approssimazione +/- 10%*

Paoli Torque Sockets available on demand.

Barre di torsione Paoli disponibili su richiesta.

1" COMMERCIAL TORQUE SOCKETS BARRE DI TORSIONE COMMERCIALI

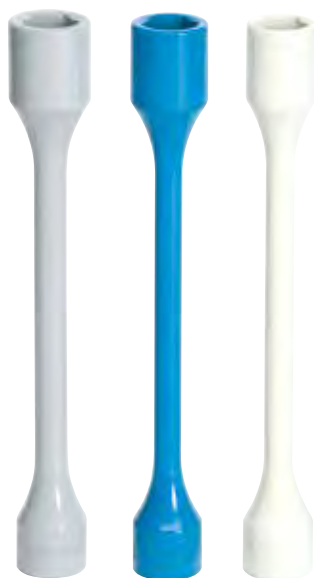

Product name <i>Nome prodotto</i>	Product code <i>Codice prodotto</i>	●	Nm*	Ft-lbs	Length <i>Lunghezza mm</i>	Length <i>Lunghezza in</i>
CBTM1X24X300	04.02.005.001	24 mm	300	221	305 mm	12 in
CBTM1X27X400	04.02.006.001	27 mm	400	295	305 mm	12 in
CBTM1X27X450	04.02.006.002	27 mm	450	332	305 mm	12 in
CBTM1X29X400	04.02.007.001	29 mm	400	295	305 mm	12 in
CBTM1X30X450	04.02.008.001	30 mm	450	332	305 mm	12 in
CBTM1X30X550	04.02.008.002	30 mm	550	406	305 mm	12 in
CBTM1X32X500	04.02.009.001	32 mm	500	369	305 mm	12 in
CBTM1X32X600	04.02.009.002	32 mm	600	443	305 mm	12 in
CBTM1X32X700	04.02.009.003	32 mm	700	516	305 mm	12 in
CBTM1X32X650	04.02.009.005	32 mm	650	479	305 mm	12 in
CBTM1X33X500	04.02.010.001	33 mm	500	369	305 mm	12 in
CBTM1X33X600	04.02.010.002	33 mm	600	443	305 mm	12 in
CBTM1X33X650	04.02.010.003	33 mm	650	479	305 mm	12 in
CBTM1X33X700	04.02.010.004	33 mm	700	516	305 mm	12 in

(*) Indicative torque value: accuracy of +/- 10%
 (*) *Valore di coppia indicativo: approssimazione +/- 10%*

Paoli Torque Sockets available on demand.
Barre di torsione Paoli disponibili su richiesta.



PAOLI: SAFETY FIRST

- Improved operator safety: two-handed use requirement
- If the side sensor on the handle is not pressed, the product immediately stops working by releasing the air pressure:
 - result: no type of accident due to hoses under pressure or superficial use of the product itself.
- The mobile working unit signals the presence of electricity and allows you to stop the pressurized system with an emergency "Stop" button.

Perfect for workplaces where a high level of safety is required for operators!

Available for: DP217, DP251, DP320, DP256 BG, DP362 BG.

- *Sicurezza migliorata per l'operatore: obbligo di utilizzo a due mani*
- *Se non viene premuto il sensore laterale sulla maniglia, il prodotto smette immediatamente di funzionare scaricando la pressione dell'aria:*
 - *risultato: nessun tipo di incidente dato da tubi in pressione o da utilizzo superficiale del prodotto stesso.*
- *La mobile working unit segnala la presenza di energia elettrica e permette di fermare l'impianto in pressione con un pulsante "Stop" di emergenza.*

Perfetto per luoghi di lavoro dove si richiede alto livello di sicurezza per gli operatori!

Disponibile per: DP217, DP251, DP320, DP256 BG, DP362 BG.

AVAILABLE FOR
DISPONIBILE PER



DP 217



DP 251



DP 320

DP 256 BG



DP 362 BG



MOBILE WORKING UNIT

DP 251 connected to
Mobile Working Unit

*DP 251 collegata a Mobile
Working Unit*

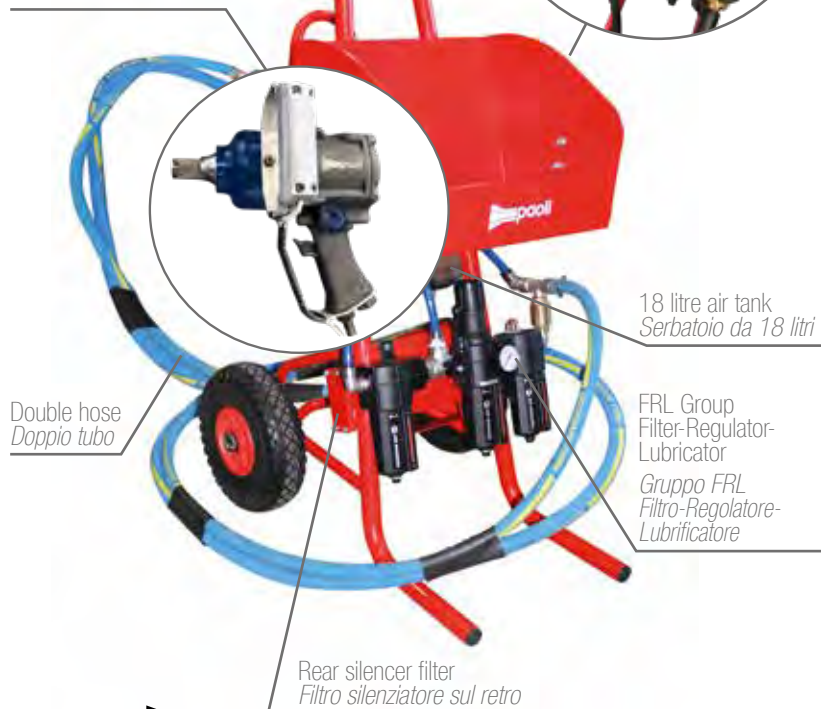

Double hose
Doppio tubo

18 litre air tank
Seratoio da 18 litri

FRL Group
Filter-Regulator-
Lubricator

*Gruppo FRL
Filtro-Regolatore-
Lubrificatore*

Rear silencer filter
Filtro silenziatore sul retro

 paoli

OIL SUCTION DRAINERS
ASPIRATORI OLIO



B.49.01.0002
Con precamera
With prechamber



B.49.01.0003

Product code <i>Codice prodotto</i>	B.49.01.0002	B.49.01.0003
Tank volume <i>Volume serbatoio</i>	80 l.	80 l.
Collecting tray volume <i>Volume vasca raccolta</i>		
Prechamber volume <i>Volume precamera</i>	8 l.	
Emptying pressure <i>Pressione di svuotamento</i>	0,5 bar	0,5 bar

OIL RECOVERY AND SUCTION DRAINERS
RECUPERATORI E ASPIRATORI OLIO



B.49.01.0004



B.49.01.0005
Modello a pantografo
Pantograph model

Product code <i>Codice prodotto</i>	B.49.01.0004	B.49.01.0005
Tank volume <i>Volume serbatoio</i>	80 l.	80 l.
Collecting tray volume <i>Volume vasca raccolta</i>	12 l.	22 l.
Prechamber volume <i>Volume precamera</i>	8 l.	6 l.
Emptying pressure <i>Pressione di svuotamento</i>	0,5 bar	0,5 bar

OIL GRAVITY DRAINER
RECUPERATORE PER CADUTA OLIO



Product code
Codice prodotto B.49.01.0001

Tank volume
Volume serbatoio 80 l.

Collecting tray volume
Volume vasca raccolta 12 l.

Emptying pressure
Pressione di svuotamento 0,5 bar

Fixed oil transfer unit
Unità fissa travaso olio



B.49.02.0001
For 200 litres drums.
Compression ratio 3:1.
Per fusti 200 litri.
Rapporto di compressione 3:1.

NEW OIL TRANSFER
TRAVASO OLIO NUOVO

Pneumatic oil distributor
Distributore pneumatico olio



B.49.02.0003
Capacity: 50 litres.
With manual valve.
Capacità: 50 litri.
Con pistola manuale.

Mobile oil transfer trolley unit
Unità mobile carrellata per travaso olio



B.49.02.0002
Trolley unit for 200 litres drums.
With digital litre-counter.
Compression ratio 3:1.
Unità mobile per fusti 200 litri.
Con contaltri digitale.
Rapporto di compressione 3:1.

The range of Checkpoint products gives users improved visibility of nut loosening. It also prevents safety critical issues such as loose vehicle wheels or structural weaknesses where nuts have been used as core to the design.

Checkpoint products are applicable in all the areas where nuts are critical to safety and structural integrity, particularly if subjected to harsh environments.

La gamma di prodotti Checkpoint migliora la visibilità da parte degli utenti dell'allentamento dei dadi. Previene inoltre le criticità di sicurezza come ruote di veicoli allentate o debolezze strutturali in cui i dadi sono stati utilizzati come base per la progettazione.





I prodotti Checkpoint sono applicabili in tutti i settori in cui i dadi hanno un'importanza cruciale per la sicurezza e l'integrità strutturale, in particolar modo nei casi in cui vengono sottoposti a condizioni ambientali difficili.

AVAILABLE COLOURS
COLORI DISPONIBILI

	Checkpoint ^{ORIGINAL}	Dustite®	Dustite ^{LP} ®	Checklink®	Checklock ^{SO} ®
	●	●	●	●	
	●	●	●	●	
	●	●	●		
	●	●	●		
	●	●			
	●	●	●		
	●	●	●		
	●	●	●		
	○	○			
	●	●	●		

Steel

APPLICATIONS
APPLICAZIONI

	Checkpoint ^{ORIGINAL}	Dustite®	Dustite ^{LP} ®	Checklink®	Checklock ^{SO} ®
 Commercial vehicles Veicoli commerciali	●	●	●	●	●
 Buses Autobus	●	●	●	●	●
 Railway Ferrovie	●				●
 Mining Miniere	●	●	●	●	●
 Agriculture Mezzi agricoli	●	●	●	●	●

Checkpoint Original provides a clear indication of wheel nut movement on vehicles and of good brakes condition. Its application has since been introduced to different sectors in order to provide a solution to loosened nuts on plant structures, rail tracks etc.

Il Checkpoint Original indica con chiarezza l'allentamento dei dadi nelle ruote dei veicoli e il buono stato dei freni. La sua utilità viene ora impiegata in differenti settori industriali in cui viene richiesto un monitoraggio costante delle condizioni degli organi di fissaggio.



Checkpoint ORIGINAL®

FUNCTIONS AND BENEFITS FUNZIONI E VANTAGGI

Primary Functions: Indicates nut loosening and overheating.

Primary Benefits: Improved safety of nut fittings. Facilitates quick and easy visual checks and audits. A cost effective solution reducing maintenance costs and saving time.

Funzione principale: indica l'allentamento e il surriscaldamento della zona dadi.

Principali benefici: con un semplice colpo d'occhio verifica con facilità la situazione del fissaggio dei dadi. L'economicità permette di ridurre i costi e i tempi di manutenzione e conseguente risparmio economico.

TECHNICAL FEATURES CARATTERISTICHE TECNICHE

Sizes: 17 to 50 mm.

Material: High-grade Polymer.

Melt Temperature: 125°C (standard);
165°C (high temperature).

Misure: da 17 a 50 mm.

Materiale: Polimero vergine di alta qualità.

Temperatura di fusione: 125°C
(standard); 165°C (alta temperatura).

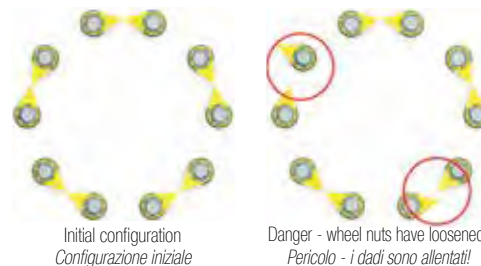

Dustite combines a nut loosening indicator and a dust cap which helps to protect the nut.

Il Dustite combina l'indicatore di allentamento dei dadi con un cappuccio antipolvere che aiuta a proteggere il dado.



Dustite®

FUNCTIONS AND BENEFITS FUNZIONI E VANTAGGI



Primary Functions: Indicates nut loosening and overheating. Protective cap helps to prevent nut damage.

Primary Benefits: Improved safety of nut fittings, facilitates quick and easy visual checks and audits. A cost effective solution reducing maintenance costs and saving time.

Funzione principale: indicare l'allentamento e il surriscaldamento della zona dadi. Il cappuccio protettivo aiuta a prevenire il danneggiamento dei dadi.

Principali benefici: migliora la sicurezza del fissaggio del dado, permette una facile e veloce verifica della situazione risparmiando tempo e denaro nella manutenzione generale del mezzo.

TECHNICAL FEATURES CARATTERISTICHE TECNICHE

Sizes: 24-27-28-30-32-33-38-41 mm.

Material: High-grade Polymer.

Melt Temperature: 125°C (standard); 165°C (high temperature).

Misure: 24-27-28-30-32-33-38-41 mm.

Materiale: Polimero vergine di alta qualità.

Temperatura di fusione: 125° C (standard); 165° C (alta temperatura).

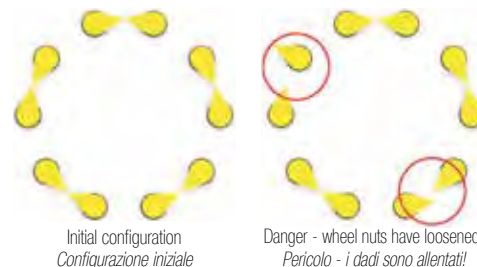

Dustite LR (long reach) combines a nut loosening indicator and a dust cap. Dustite LR is designed specifically for use on vehicle wheels with trims.

Il Dustite LR (long reach) combina l'indicatore di allentamento dei dadi con un cappuccio antipolvere.

Il Dustite LR è progettato specificatamente per le ruote in cui è presente la ghiera copridadi.



Dustite LR®

FUNCTIONS AND BENEFITS FUNZIONI E VANTAGGI

Primary Functions: Indicates nut loosening and overheating. Protective cap helps to prevent nut damage.

Primary Benefits: Improved safety of nut fittings, facilitates quick and easy visual checks and audits. A cost effective solution reducing maintenance costs and reducing vehicle downtime.

Funzione principale: indicare l'allentamento e il surriscaldamento della zona dadi. Il cappuccio protettivo aiuta a prevenire il danneggiamento dei dadi.

Principali benefici: migliora la sicurezza del fissaggio del dado, permette una facile e veloce verifica della situazione risparmiando tempo e denaro nella manutenzione generale del mezzo.

TECHNICAL FEATURES CARATTERISTICHE TECNICHE

Sizes: 17-19-20-21-22-24-27-30-32-33 mm.

Material: High-grade Polymer.

Melt Temperature: 125°C (standard); 165°C (high temperature).

Misure: 17-19-20-21-22-24-27-30-32-33 mm.

Materiale: Polimero vergine di alta qualità.

Temperatura di fusione: 125° C (standard); 165° C (alta temperatura).

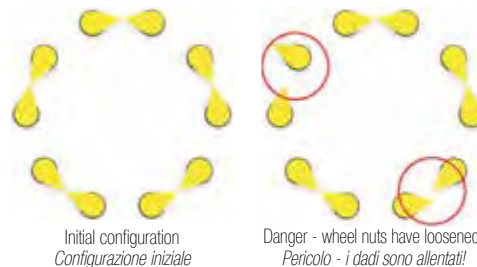

Dustite combines a nut loosening indicator and a dust cap which helps to protect the nut.

Il Dustite combina l'indicatore di allentamento dei dadi con un cappuccio antipolvere che aiuta a proteggere il dado.



Checklink®

FUNCTIONS AND BENEFITS FUNZIONI E VANTAGGI



Primary Functions: To indicate nut loosening, nut over-heating and to provide a retaining function.

Primary Benefits: Improved safety of nut fittings, facilitates quick and easy visual checks and audits. A cost effective solution reducing maintenance costs and saving time.

Funzione principale: indicare l'allentamento e il surriscaldamento della zona dadi; trattenere i dadi.

Principali benefici: migliora la sicurezza del fissaggio del dado, permette una facile e veloce verifica della situazione risparmiando tempo e denaro nella manutenzione generale del mezzo.

TECHNICAL FEATURES CARATTERISTICHE TECNICHE

Sizes: 19-21-22-24-27-30-32-33 mm.

Material: High-grade Polymer.

Melt Temperature: 125°C (standard); 165°C (high temperature).

Misure: 19-21-22-24-27-30-32-33 mm.

Materiale: Polimero vergine di alta qualità.

Temperatura di fusione: 125° C (standard); 165° C (alta temperatura).

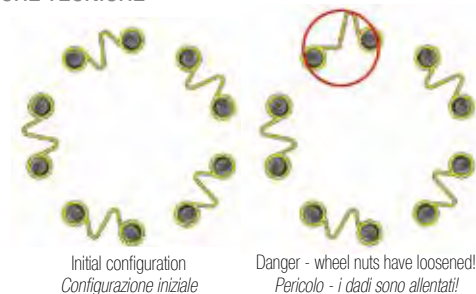



TÜV CERTIFICATION
CERTIFICAZIONE TÜV

ChecklockSQ helps to retain two adjacent nuts.

Il ChecklockSQ® aiuta a trattenere i due dadi su cui è installato.

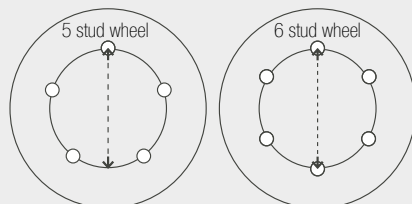

How to measure the pitch circle diameter (PCD)
Come misurare l'interasse delle colonnine



ChecklockSQ®

FUNCTIONS AND BENEFITS FUNZIONI E VANTAGGI

Primary Functions: Provides a retaining function, reducing the likelihood of nuts loosening.

Primary Benefits: Improved safety of nut fittings, facilitates quick and easy visual checks and audits. A cost effective solution reducing maintenance costs and saving time, as it can be fitted without any special tool.

Funzione principale: *trattiene i dadi e riduce le possibilità di perdere i dadi.*

Principali benefici: *migliora la sicurezza del fissaggio del dado, permette una facile e veloce verifica della situazione risparmiando tempo e denaro nella manutenzione generale del mezzo, perché non è necessario uno strumento specifico per installarlo.*

TECHNICAL FEATURES CARATTERISTICHE TECNICHE

Material: High quality premium Stainless Steel.

Materiale: *Acciaio Inox di alta qualità.*

SIZE GUIDE GUIDA ALLE MISURE

	17	19	24	27	30	32	33
Nut size <i>Misure dadi (mm)</i>							
Studs <i>Colonnine</i>	4	4 5	6	5 6 8	8	10 10 10	10
Pitch circle diameter <i>Interasse colonnine</i>	139,7	139,7 165,1	245	165.1 245 275	275	225 335 285	335





55

47



LOP



Cetilar

47

ROYAL
RACING MACHINES

HARDANI

Cetilar
MOTORSPORTS
THE 24 HOURS
OF LE MANS

Green

MILLORETTI

PROFESSIONAL TYRE INFLATING GUNS PISTOLE GONFIAGOMME PROFESSIONALI

DIGITAL TYRE-INFLATING GUN PISTOLA GONFIAGOMME DIGITALE

DTIG/1



Unit of measure:
PSI, BAR, Kpa, Kg / cm²
Unità di misura:
PSI, BAR, Kpa, Kg / cm²

ANALOG TYRE-INFLATING GUNS PISTOLA GONFIAGOMME ANALOGICA

ATIG/2



Double scale:
BAR + psi
Doppia scala:
BAR + PSI

ATIG/3



Mod. CEE:
The calibration is
in to directive
CEE n° 86/217

Product name	Nome prodotto	DTIG/1	ATIG/2	ATIG/3
Product code	Codice prodotto	G.06.01.0002	G.06.01.0001	G.06.01.0005
Pressure gauge	Manometro	Ø 80	Ø 80	Ø 80
Working Pressure	Pressione di esercizio	0 ÷ 12 BAR	0 ÷ 12 bar	0 ÷ 10 bar
Hose lenght	Lunghezza del tubo	100 cm	100 cm	50 - 100 cm
Batteries	Batterie	Lithium 3V		

DEMOUNTABLE STAND FOR PAOLI PRODUCTS ESPOSITORE SMONTABILE PER PRODOTTI PAOLI



Catalogue holder
Portacataloghi



Kit for the presentation of Paoli impact wrenches. Versions available for all models.
Kit per l'esposizione degli avvitatori Paoli. Versioni disponibili per tutti i modelli

Shelf for battery impact wrenches, sockets and Paoli accessories

Ripiano per avvitatori a batterie, bussole e accessori Paoli



The new Paoli demountable stand has been designed to provide the customer with a commercial means for displaying Paoli products for sale. Perfect for retailers, the new stand is a real marketing tool aimed at displaying Paoli products in the best possible way.

Il nuovo espositore Paoli è stato ideato per fornire al cliente un veicolo commerciale per l'esposizione dei prodotti destinati alla vendita.

Perfetto per i rivenditori, il nuovo espositore è un vero e proprio strumento di marketing volto ad esporre nel miglior modo possibile i prodotti Paoli.

B.26.0030

TABLE DISPLAYERS FOR PAOLI IMPACT WRENCHES
ESPOSITORI DA TAVOLO PER AVVITATORI PAOLI



B.26.0010



B.26.0009



B.26.0015

Table displayers made in steel for Paoli impact wrenches with quick release couplings included.

Models available: 1 position, 3 positions, 5 positions.

Espositori da tavolo in metallo per avvitatori Paoli completi di attacchi a sganciamento rapido.

Modelli disponibili: 1 posizione, 3 posizioni, 5 posizioni.

HAMMER MECHANISM AND HANDLE TAPE
NASTRO ISOLANTE PER MASSA BATTENTE
ED IMPUGNATURA



B.23.0174

A high performance tape born in the aerospace industry for use in extreme temperature swing environments. This state-of-the-art polymer is extremely light weight and capable of handling continual operating temperatures up to 850° F.

- Reflects up to 80% of radiant heat
- Easy to install and remove
- Self Adhesive

Un nastro isolante altamente performante nato nell'industria aerospaziale per l'utilizzo in ambienti sottoposti a temperature estreme. Questo polimero all'avanguardia è estremamente leggero ed in grado di tollerare temperature fino a 850° F.

- Riflette fino all'80% del calore radiante
- Facile da installare e da rimuovere
- Autoadesivo

COVERS FOR PAOLI IMPACT WRENCHES
COVER PER AVVITATORI PAOLI



B.18.0037



B.18.0042



B.18.0041



B.18.0001



Rubber covers especially designed for Paoli impact wrenches. Strong and durable. New design. Available for:

- DP 1050 (B.18.0037)
- DP 1800 (B.18.0042)
- Red Devil 2.0 Street Legal (B.18.0041)

Cover in gomma appositamente progettate per gli avvitatori Paoli. Robuste e durevoli. Nuovo design. Disponibili per:

- DP 1050 (B.18.0037)
- DP 1800 (B.18.0042)
- Red Devil 2.0 Street Legal (B.18.0041)

Transparent plastic covers for Paoli impact wrenches. Easy to assemble. Available for:

- DP 176
- DP 196

Cover in plastica trasparente per avvitatori Paoli. Disponibile per:

- DP 176
- DP 196

SUSPENSION SHACKLES AND HANDLES GANCI DI SOSPENSIONE E MANIGLIE



Product name <i>Nome prodotto</i>	Code <i>Codice</i>	Impact wrench <i>Avvitatore</i>
Eyebolts <i>Golfari</i>	D.09.10.0001	DP 362, DP 256 BG, DP 362 BG, DP 251
	D.09.10.0009	DP 217
	D.01.36.0001	DP 320, DP 321
Handles <i>Maniglie</i>	D.01.36.0003	DP 236, DP 246
	D.01.36.0009	DP 217, DP 251, DP 256 BG, DP 362 BG (ATEX version <i>versione ATEX</i>)
	D.01.36.0011	DP 217, DP 251, DP 256 BG, DP 362 BG (standard version <i>versione standard</i>)
Hangers <i>Ganci di sostegno</i>	D.01.28.0006	DP 92, DP 92 XC
	D.01.28.0005	DP 176
	D.01.28.0008	DP 196
	D.01.28.0012	DP 37, DP 38
Suspension shackles <i>Ganci di sospensione</i>	D.01.28.0002	DP 246
	D.01.28.0001	DP 320, DP 321

LUBRICANTS LUBRIFICANTI



Lube oil and grease <i>Olio e grasso lubrificanti</i>	Quantity <i>Quantità</i>	Code <i>Codice</i>
Special oil for Paoli air impact wrench motors <i>Olio speciale per i motori degli avvitatori Paoli</i>	33 ml	B.27.0006
	1 lt	B.27.0004
	5 lt	B.27.0005
Special oil for Paoli air impact wrench hammer mechanism <i>Olio speciale per le masse battenti degli avvitatori Paoli</i>	1 lt	B.27.0009
	5 lt	B.27.0010
Special grease for Paoli impact wrench hammer mechanism <i>Grasso speciale per le masse battenti degli avvitatori Paoli</i>	30 gr	B.27.0022
	1 kg	B.27.0007
Oil for Paoli hydraulic control unit <i>Olio per centralina idraulica</i>	15 lt	B.27.0013
Special spray lubricant for Paoli air impact wrench motors <i>Lubrificante spray speciale per il motore degli avvitatori Paoli</i>	500 ml	B.27.0016

SERVICE KITS KIT MANUTENZIONE

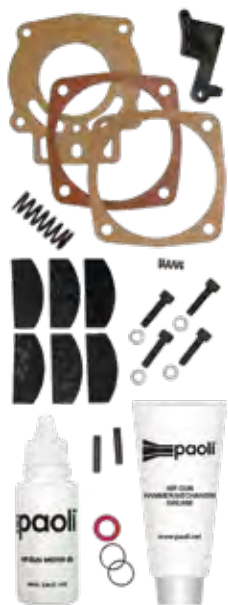

As manufacturers of our wheel guns we make available to our customers all the spare parts and service kits for maintenance and repair.

Come produttori dei nostri avvitatori mettiamo a disposizione dei nostri clienti tutti i ricambi ed i kit manutenzione per la manutenzione e la riparazione.

Code Codice	B.34.0177	B.34.0019	B.34.0193	B.34.0080	B.34.0006	B.34.0048	B.34.0178	B.34.0090	B.34.0005	B.34.0022	B.34.0023
Impact wrench Avvitatore	BUTTERFLY	DP92, DP92XC, DP 93	DP1040	DP1050	DP36	DP1800 1/2* DP1800 3/4*	DP1800 PLUS	RED DEVIL 2.0	DP34	DP176	DP196 DP197
Oil Olio		●		●	●	●	●	●		●	●
Grease Grasso	●	●		●	●	●	●	●		●	●
Roller Rullo volano		●								●	●
Spring Molla	●	●		●	●	●	●			●	●
Rear Gasket Guarnizione motore		●		●	●			●		●	●
Front gaskets Guarnizioni anteriori		●			●					●	●
Trigger handle gasket Guarnizione Impugnatura											
Trigger Leva avviamento					●						
Motor Vane Paletta motore	●	●		●	●	●	●	●		●	●
Steel Ball Sfera				●	●	●					
Muffler Foam Filtro Silenziatore		●									
Socket head cap screws Viti a testa cilindrica		●		●	●			●		●	●
Anello O-Ring O-Ring	●	●		●	●	●	●	●		●	●
Anello di tenuta Retention ring				●							
Anello Quadro Socket Retainer				●							
Spring Pin Spina elastica		●			●			●		●	●
Lock washers Rondelle di sicurezza		●						●		●	●
Washer Rondella elastica				●	●						

SERVICE KITS KIT MANUTENZIONE

Code Codice	B.34.0064	B.34.0179	B.34.0067	B.34.0183	B.34.0079	B.34.0009	B.34.0182	B.34.0068	B.34.0191	B.34.0176	B.34.0003	B.34.0069	B.34.0197	B.34.0051
Impact wrench <i>Avvitatore</i>	DP 3400	DP3500	DP217	DP219	DP1000 DP3450	DP236	DP247	DP251 DP256BG	DP3700	DP3800	DP320 DP321	DP362BG	DP382	DP635
Oil <i>Olio</i>	●	●	●	●	●	●	●	●		●	●	●	●	●
Grease <i>Grasso</i>	●	●	●	●	●	●		●		●	●	●	●	●
Roller <i>Rullo volano</i>			●	●		●		●			●	●	●	●
Spring <i>Molla</i>	●	●	●	●	●	●	●	●		●	●	●	●	●
Rear Gasket <i>Guarnizione motore</i>	●		●	●		●	●	●			●	●	●	●
Front gaskets <i>Guarnizioni anteriori</i>	●		●	●		●	●	●			●	●	●	●
Trigger handle gasket <i>Guarnizione Impugnatura</i>													●	●
Trigger <i>Leva avviamento</i>														
Motor Vane <i>Paletta motore</i>	●	●	●	●	●	●	●	●		●	●	●	●	●
Steel Ball <i>Sfera</i>	●	●			●		●			●				
Muffler Foam <i>Filtro Silenziatore</i>					●									
Socket head cap screws <i>Viti a testa cilindrica</i>	●		●	●		●	●	●			●	●	●	●
Anello O-Ring <i>O-Ring</i>	●	●	●	●	●	●	●	●		●	●	●	●	●
Anello di tenuta <i>Retention ring</i>							●							
Anello Quadro <i>Socket Retainer</i>														
Spring Pin <i>Spina elastica</i>			●	●		●	●	●			●	●	●	●
Lock washers <i>Rondelle di sicurezza</i>			●	●		●	●	●			●	●	●	●
Washer <i>Rondella elastica</i>														

PRODUCT CARE

Paoli Service is at your disposal to provide professional advices about the realization, installation and correct use of a compressed-air system, and offers the most efficient answer in the shortest time.

Moreover, we repair and overhaul all our products (impact wrenches, special equipments, hydraulic range, accessories).

We are easily reachable thanks to a dedicated telephone number and an e-mail:

E-mail: sales@paoli.net

Phone: +39.0522.364525

ASSISTENZA TECNICA

L'Assistenza Tecnica Paoli è a vostra disposizione per fornire consulenze tecniche specializzate per la realizzazione, installazione ed uso di impianti ad aria compressa e offre una risposta efficiente nel tempo più breve possibile.

Inoltre, siamo attrezzati per la riparazione e revisione di tutte le nostre forniture (avvitatori, attrezzature speciali, gamma idraulica e accessori).

Siamo facilmente raggiungibili grazie a un numero di telefono e a una e-mail dedicati.

E-mail: sales@paoli.net

Tel.: +39.0522.364525



PRODUCT CARE
ASSISTENZA TECNICA

ipaoli



After the purchase of a Paoli impact wrench, the customer takes advantage of an efficient after-sales and repair service.

Dopo l'acquisto di un avvitatore Paoli il cliente ha a propria disposizione un efficace servizio di assistenza e riparazione post-vendita.

REPAIR SERVICE SERVIZIO RIPARAZIONI

Paoli offers an internal repair service and certified assistance points, with highly qualified personnel and a 6-month

warranty. We also provide a repainting service with standard or optional color on demand.

Paoli mette a disposizione dei suoi clienti un servizio di riparazione interno e punti di assistenza certificati, con personale altamente qualificato e una garanzia di 6 mesi. Su richiesta offriamo anche la riverniciatura con colore standard o a scelta.

AFTER-SALES SERVICE ASSISTENZA POST-VENDITA

This service is aimed at assisting and supporting our customers' needs after the purchase of Paoli products. If you have any doubt, do not hesitate to contact us. We will be happy to help you!

Questo servizio è volto ad affiancare e a supportare le necessità dei nostri clienti dopo l'acquisto del prodotto.

Per qualsiasi dubbio non esitate a contattarci. Saremo lieti di aiutarvi!

E-mail: sales@paoli.net
Phone: +39.0522.364525

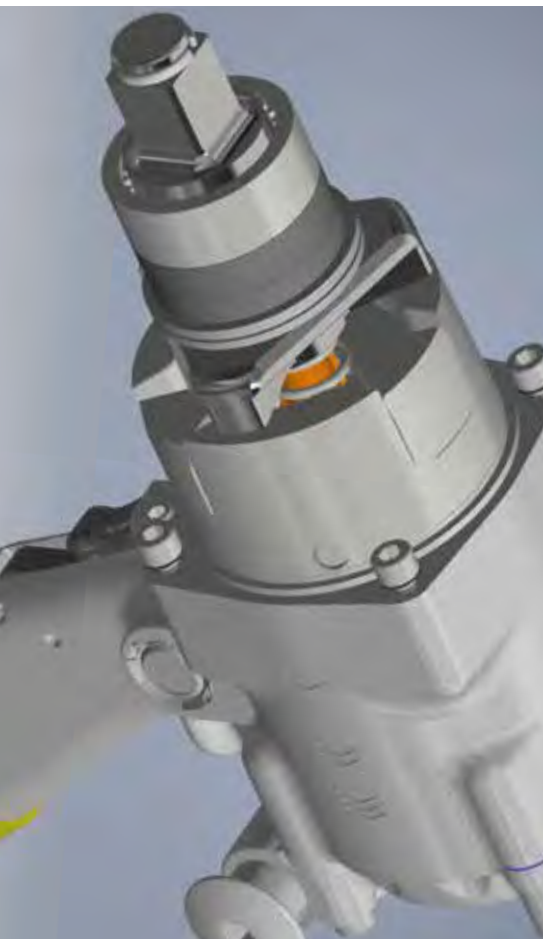

Since 1968 we have been manufacturing wheel guns, and now we would like to get our professionalism and experience available to our customers to an even greater extent.

We have invested heavily in research and development in order to get procedures and instruments suitable for the study and creation of products most suited to the growing needs of the automotive and industry fields. Dino Paoli is in fact able to offer to customers an Engineering service which consists in the development of variations of wheel guns components customized according to different needs.

The engineering offer covers several areas: performances, durability, ergonomics, lightness. To obtain these results we use and work on materials from the aviation and military industry, such as special steels, carbon fibre, aluminium and magnesium alloy, titanium.

The design of the new components is tested using finite element analysis (FEM) and once designed (CAD) these are produced using CAM, which allows us to easily obtain even geometrically complex parts.

We also have a range of suppliers skilled in heat treatments, who can identify the expected mechanical features accurately.

Costruiamo avvitatori pneumatici dal 1968, e ora vogliamo rendere disponibili la nostra professionalità ed esperienza ai nostri clienti in maniera ancora maggiore.

Abbiamo investito in maniera significativa nella ricerca e nello sviluppo, per ottenere strumenti e metodi idonei allo studio e alla creazione di prodotti più adatti alle crescenti necessità dei settori automotive e industry. La Paoli è infatti pronta ad offrire ai clienti un servizio ingegneristico che consiste nello sviluppo di variazioni dei componenti dell'avvitatore in base alle varie necessità.

Questa proposta ingegneristica copre diverse aree: prestazioni, durata, ergonomia e leggerezza. Per ottenere questi risultati utilizziamo e lavoriamo materiali usati nell'industria militare e nell'aviazione, come speciali tipi di acciaio, fibra di carbonio, leghe di alluminio e magnesio, titanio.



Il design dei nuovi componenti viene testato utilizzando il metodo degli elementi finiti (FEM). Una volta progettati (CAD), vengono prodotti tramite il CAM, che ci permette di realizzare facilmente anche le più complesse parti geometriche.

Abbiamo anche una serie di fornitori esperti nel trattamento del calore, che riescono ad identificare accuratamente le caratteristiche meccaniche previste.



DIN 267 STANDARD NORMA DIN 267

The numbers given in the line of text [e.g. 3.6] are indexes in which the first number [e.g. 3] represents 10% of the breaking load in kg/mm², whilst the second [e.g. 6] represents 10% of the ratio between the minimum elastic limit and the minimum breaking load.

I numeri rappresentati nella riga di testa [es. 3.6] sono degli indici in cui il primo numero [es. 3] rappresenta il 10% del carico di rottura in kg/mm², mentre il secondo [es. 6] rappresenta il 10% del rapporto tra il limite elastico minimo ed il carico di rottura minimo.

Bolt quality		Qualità del bullone	3.6	4.6	4.8	5.6	5.8	6.8	8.8	10.9	12.9
			Torque	Torque	Torque	Torque	Torque	Torque	Torque	Torque	Torque
(mm)	(mm)		Coppia	Coppia	Coppia	Coppia	Coppia	Coppia	Coppia	Coppia	Coppia
			(Nm)	(Nm)	(Nm)	(Nm)	(Nm)	(Nm)	(Nm)	(Nm)	(Nm)
M4	3	7	0.85	1.1	1.4	1.5	1.9	2.3	2.9	4.1	4.9
M5	4	9	1.7	2.2	2.8	3.0	3.7	4.5	6.0	8.5	10
M6	5	10	2.9	3.9	4.8	5.1	6.4	7.7	10	14	17
M8	6	13	7	9.3	12	12	16	19	25	35	41
M10	8	17	14	19	23	25	31	37	49	69	83
M12	10	19	24	32	40	43	54	65	86	120	145
M14	12	22	39	51	64	68	86	105	135	190	230
M16	14	24	59	79	98	105	130	155	210	295	355
M18	14	27	81	110	135	145	180	215	290	405	485
M20	17	30	115	155	190	205	255	305	410	580	690

Note: The torque values are only a rough indication and have been calculated with a friction factor of 0.125 - Nota: I valori di coppia servono solo per un'indicazione di massima e sono stati calcolati con un fattore di attrito di 0.125

	Bolt quality	Qualità del bullone	3.6	4.6	4.8	5.6	5.8	6.8	8.8	10.9	12.9
			Torque	Torque	Torque	Torque	Torque	Torque	Torque	Torque	Torque
	(mm)	(mm)	Coppia	Coppia	Coppia	Coppia	Coppia	Coppia	Coppia	Coppia	Coppia
			(Nm)	(Nm)	(Nm)	(Nm)	(Nm)	(Nm)	(Nm)	(Nm)	(Nm)
M22	17	32	155	205	260	275	345	415	550	780	930
M24	19	36	265	265	330	350	440	530	710	1000	1200
M27	19	41	295	390	490	520	650	780	1050	1500	1800
M30	22	46	395	530	660	710	880	1050	1450	2000	2400
M33	24	50	540	720	900	960	1200	1450	1900	2700	3250
M36	27	55	690	920	1150	1250	1550	1850	2450	3450	4150
M39	27	60	920	1200	1500	1600	2000	2400	3200	4500	5400
M42	32	65	1100	1500	1850	1950	2450	2950	3950	5550	6650
M45	32	70	1400	1850	2300	2450	3100	3700	4950	6950	8350
M48	36	75	1700	2250	2800	3000	3750	4450	5950	8400	10100
M52	36	80	2150	2900	3600	3850	4800	5750	7650	10800	12900
M56	-	85	2700	3600	4500	4800	5950	7150	9550	13400	16100
M60	-	90	3350	4450	5550	5950	7400	8900	11900	16700	20000
M64	-	95	4000	5350	6700	7150	8950	10700	14300	20100	24100
M68	-	100	4850	6500	8100	8650	10800	13000	17300	24300	29100

Note: The torque values are only a rough indication and have been calculated with a friction factor of 0.125 - Nota: I valori di coppia servono solo per un'indicazione di massima e sono stati calcolati con un fattore di attrito di 0.125



paoli™

17mm



FAQ
DOMANDE FREQUENTI



Handmade in
USA
||| baci |||

What is the working pressure in dynamic?

The working pressure (6.3 up to 9 bar) must be adjusted dynamically: that is, near the impact wrench and while pressing the start lever.

What is the tightening torque?

The tightening torque is the force that a rotation generates around an axis of a screw or nut.

How is the impact wrenches performance measured?

There is no harmonized standard so each producer decrees data differently/independently. Paoli measures the performances with the Skidmore load cell and they are easily verifiable by anyone with measuring instruments.

How is Dino Paoli committed to reducing the environmental impact?

Paoli is working to minimize the plastic in packaging to aim at achieving the goal of the plastic free company.

Cos'è la pressione di utilizzo in dinamico?

La pressione di utilizzo (6,3 fino a 9 bar) deve essere regolata in dinamico: cioè in prossimità dell'avvitatore e mentre si preme la leva d'avviamento a vuoto.

Cos'è la coppia di serraggio?

È la forza che una rotazione genera intorno ad una asse di una vite o dado.

Come vengono misurate le performance degli avvitatori?

Non esiste una norma armonizzata quindi ogni produttore decreta dati in modo diverso/independente. Paoli misura le performances con cella di carico Skidmore e sono facilmente riscontrabili da chiunque disponga di strumenti di misura.

In che modo Dino Paoli si impegna per ridurre l'impatto ambientale?

Paoli sta lavorando per ridurre al minimo la plastica degli imballi per puntare ad arrivare all'obiettivo del plastic free company.



www.paoli.net - sales@paoli.net

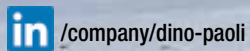

[/company/dino-paoli](https://www.linkedin.com/company/dino-paoli)



[/dinopaoli](https://www.facebook.com/dinopaoli)



[/dinopaoli](https://www.instagram.com/dinopaoli)



[/dinopaoli](https://twitter.com/dinopaoli)



[DINO PAOLI SRL](https://www.youtube.com/DINO_PAOLI_SRL)

The information, images and/or data contained in this catalogue are copyrighted by Dino Paoli S.r.l.

All other logos, products and company names mentioned in the Dino Paoli S.r.l. General Catalogue are trademarks of their respective owners.

Models, specifications, colors and codes are subject to change without prior notice due to continuous improvements.

Thank you for your interest in our products.

Le informazioni, le immagini e/o i dati contenuti in questo catalogo sono protetti da copyright Dino Paoli S.r.l.

Tutti gli altri loghi, prodotti e nomi di società menzionati nel Catalogo Generale Dino Paoli S.r.l. sono marchi registrati dei rispettivi proprietari.

Modelli, caratteristiche, colori e codici sono soggetti a modifiche senza preavviso a causa dei continui miglioramenti.

Grazie per il vostro interesse nei nostri prodotti.





Dino Paoli S.r.l.
Via G. Dorso, 5 - 42124 Reggio Emilia - Italy
Tel. +39 0522 364511 - Fax + 39 0522 304864
www.paoli.net - sales@paoli.net

Paoli USA
150 Ostwalt Amity Rd, Ste D101,
Troutman NC 28166 - Tel. (704) 389 9000
www.paoliusa.net - info@paoliusa.net

